



Realtech

www.realtechotomasyon.com.tr



İstanbul

Oruçreis Mah. Giyimkent 5. Sk.
Giyimkent B57 NO: 82/A
Esenler İstanbul / Türkiye

0 (212) 438 11 80
0 (533) 374 45 92

info@realtechotomasyon.com.tr

Gaziantep

Mücahitler Mah. 52008 Nolu Cad. No:3/J
Şehitkamil Gaziantep / Türkiye

0 (342) 503 11 83
0 (544) 948 40 40

ibrahim@realtechotomasyon.com.tr



Operation **Manual**

DA180 Series

Basic AC Servo Drive



Preface

Thanks for choosing DA180 series basic AC servo drive (DA180 drive for short).

DA180 drive is a new generation of basic servo drive that INVT develops, using the modular design, USB communication with the upper computer software, and the available control bus options include Modbus,CANopen,and EtherCAT. In addition, DA180 drive supports online and offline inertia identifying, gain switching, auto and manual notch filters, auto and manual vibration control filters, medium-frequency vibration suppression, internal point-to-point (PTP) control, and absolute encoders.

The electromagnetic compatibility design enables DA180 drive to provide strong anti-electromagnetic interference capacity but also achieve low noise and electromagnetic interference weakening in the application sites.

This manual describes the installation, wiring, parameter setting, fault diagnosis, and daily maintenance. Read this manual carefully before installing DA180 drive so that it works properly.

If the product is ultimately used for military affairs or weapon manufacture, it will be listed on the export control formulated by *Foreign Trade Law of the People's Republic of China*. Rigorous reviews and necessary export formalities are required before the export.

INVT reserves the right to update manual information without prior notice.

Safety precautions

Safety symbols



Read this manual and follow the instructions.



Do not touch terminals within 15 minutes after power-on or power-off. Otherwise, electric shock may result.



Do not touch the heat sink. Otherwise, burns may result.



The contact current can reach 0.5mA. Reliable grounding must be complete before the use.

The safety symbols are marked in the front or side of the servo drive. Follow the safety instructions when operating on the servo drive.

Recycling symbol



When the life cycle ends, the product should enter the recycling system. Dispose of it separately at an appropriate collection point instead of placing it in the normal waste stream.

Check the following safety precautions before the installation, wiring, operation, maintenance, or inspection:

- Ensure that the AC power supply is consistent with the rated voltage of the drive. Otherwise, drive damages, body injuries, or fire may result.
- Do not connect an input power cable to an output terminal. Otherwise, drive damages may result.
- Do not carry out any insulation and voltage withstand test to the drive directly, and do not test the control circuit of the drive by megameter.
- Connect the drive and motor in the correct phase sequence. Otherwise, drive faults or damages may be caused.
- To avoid accidents, disconnect the motor from the drive before trial operation, and then run the motor independently.
- Ensure that the drive can be disconnected from the power supply by the emergency switch before mechanical running.
- Set the corresponding parameters before operation. Otherwise, the drive may run abnormally or unexpectedly due to load issues.

- Only qualified electrical engineers can carry out the wiring. Otherwise, electric shock or fire may result.
- Do not touch the conductive parts directly, and do not connect any external cables (especially heavy-current related) to the housing or in short-circuited way. Otherwise, electric shock or short circuit may result.
- Rewire the drive at least 15 minutes after disconnecting it from the power supply. Otherwise, electric shock may result.
- Use proper grounding techniques because the touch current may reach 0.5mA. Otherwise, electric shock may result.
- Do not touch the heat sink or external brake resistor during operation. Otherwise, burns may result due to high temperature.
- Install the overcurrent protector, leakage current protector, and emergency brake, and ensure the normal usage after wiring. Otherwise, electric shock, body injuries, or fire may result.
- The leakage current may exceed 2mA during the drive running. Ground with proper techniques. Ensure that the grounding resistance is less than 10Ω and the PE earth conductor and the phase conductor are the same in conductivity (with the same cross-sectional area).
- Dispose of a scrap drive as industrial waste.

Contents

Preface	I
Safety precautions	II
Contents	IV
1 Overview	1
1.1 Servo drive	2
1.2 Servo motor	9
1.3 Cables	11
1.4 Brake resistor specifications	14
2 Installation instructions	15
2.1 Drive dimensions.....	16
2.2 Drive installing.....	17
2.3 Motor outline and mounting dimensions.....	19
2.4 Motor installing.....	20
2.5 Servo-motor technical parameters	21
3 Wiring instructions	22
3.1 System wiring.....	23
3.2 Main circuit terminal wiring (1PH 220V)	26
3.3 Motor power cable wiring	27
3.4 Motor encoder cable wiring	27
3.5 Wiring for control I/O terminal CN1	28
3.6 Wiring for encoder terminal CN2.....	29
3.7 Wiring for RS485/CAN communication terminal CN3	29
3.8 Wiring for USB terminal CN4	30
4 Control modes	31
4.1 Standard wiring diagram for position control	32
4.2 Standard wiring diagram for speed control.....	33
4.3 Standard wiring diagram for torque control	34
4.4 CN1 function description	35
4.5 Wiring description for CN1	51
5 Operating and running	56
5.1 Running.....	57
5.2 Display and operating	67
6 Function codes	75
6.1 Basic control (group P0).....	76
6.2 Autotuning control (group P1)	104
6.3 Motor control (group P2)	112
6.4 I/O management (group P3)	127
6.5 Extension and application (group P4)	144

6.6 Program Jog, homing, and PTP control (group P5)	163
6.7 Application functions (group P6)	178
6.8 PTP control (groups PtP0, PtP1, and PtP2)	183
6.9 Status monitoring	220
7 Commissioning.....	237
7.1 Instructions on identifying inertia	238
7.2 General methods for adjusting parameters	239
7.3 Mechanical resonance suppressing	244
7.4 Gains switching	245
8 Communication	249
8.1 General description	250
8.2 RS485	250
8.3 CANopen	255
8.4 Upper computer software	262
9 Fault handling.....	267
9.1 Servo drive faults and workarounds	268
9.2 CANopen communication faults and workarounds.....	279
10 Appendix	282
10.1 Parameters about settings	283
10.2 Parameters about monitoring	310
10.3 Common monitoring parameters	314
10.4 Fault codes	315
10.5 Parameter setting history	319

1**Overview**

1.1 Servo drive.....	2
1.1.1 Drive introduction.....	2
1.1.2 Outline drawing.....	6
1.1.3 Drive naming	7
1.1.4 Drive nameplate	8
1.1.5 Drive ratings and frame sizes	8
1.2 Servo motor	9
1.2.1 Motor nameplate.....	9
1.2.2 Motor naming	9
1.3 Cables.....	11
1.3.1 Cable nameplate	11
1.3.2 Power cable naming.....	11
1.3.3 Power cable accessory naming.....	12
1.3.4 Encoder cable naming.....	12
1.3.5 Encoder cable accessory naming.....	13
1.3.6 Motor brake cable naming	13
1.4 Brake resistor specifications	14

1.1 Servo drive

1.1.1 Drive introduction

DA180 series servo drive (100W–1kW)					
Specification			Description		
Power supply	220V system input voltage		1PH/3PH, AC 220V (±15%), 47Hz–63Hz		
Port	Control signal	Input	10 inputs (The function is configurable through parameter settings.)		
		Output	4 outputs (The function is configurable through parameter settings.)		
	Analog	Input	Two 12-bit analog inputs		
	Pulse signal	Input	1 group (of open collector input or differential input)		
		Output	1 group of differential outputs (A+/A-; B+/B-; Z+/Z-)		
	Communication	USB		1:1 communication upper computer software	
		RS485		1:n communication	
		CANopen		1:n communication (optional)	
EtherCAT		1:n communication (optional)			
Control mode			1: Position control 2: Speed control 3: Torque control 4: Switching between the position and speed modes 5: Switching between the speed and torque modes 6: Switching between the position and torque modes 7: CANopen mode 8: EtherCAT mode		
Function	Position control	Control input	1: Clearing residual pulses 2: Inhibiting command pulses 3: Switching electronic gear ratios 4: Switching vibration control		
		Control output	Such as positioning completion output		
	Pulse input	Max. pulse input frequency	Photoelectric coupling: differential input of 4Mpps or open collector input of 200kpps		
		Pulse input mode	1: Pulse + direction 2: Clockwise + counterclockwise (CW + CCW) 3: Orthogonal coding		

DA180 series servo drive (100W–1kW)			
Specification		Description	
		Electronic gear	1/10000—1000
		Filter	1. Command smoothing filter 2. FIR filter
		Analog input	Torque limit command input This allows independent CW or CCW torque limit.
		Vibration control	This can suppress 1Hz–200Hz front-end vibration and entire-machine vibration.
		Pulse output	1: This allows arbitrary frequency division settings under the encoder resolution. 2: This supports phase-B reserving.
Speed control	Control input	1: Internal command speed 1 2: Internal command speed 2 3: Internal command speed 3 4: Zero-point clamping	
	Control output	Such as speed reaching	
	Analog input	Speed command input	You can enable speed command inputs after performing relevant settings based on the analog voltage DC±10V.
		Torque limit input	This allows independent CW or CCW torque limit.
	Internal speed command	The internal eight-step speeds can be switched based on external control inputs.	
	Speed command ACC/DEC adjustment	This supports both independent ACC/DEC time setting and S-curve ACC/DEC setting.	
	Zero-point clamping	In speed mode, this allows the hybrid speed or position working manner.	

DA180 series servo drive (100W–1kW)					
Specification		Description			
		Speed command filter	First-order delay filter from the analog input speed command.		
		Speed command zero-drift control	Zero-drift suppression on external interference.		
	Torque control	Control input	Such as zero-drift clamping input.		
		Control output	Such as speed reaching.		
		Analog input	Torque command input	This allows gain and polarity settings based on analog voltage.	
			Speed limit input	This allows analog speed limits.	
		Speed limit	Speeds can be limited through parameter settings.		
		Torque command filter	First-order delay filter of the analog input speed command.		
		Torque command zero drift	Zero-drift suppression on external interference.		
	Internal position planning	Segment planning	This supports 128-segment internal position planning. The positioning can be controlled through communication.		
		Route setting	1: Position 2: Speed 3: ACC time 4: DEC time 5: Stop timer 6: Status output 7: Running mode		
			Homing	1: LS signal 2: Phase-Z signal 3: LS signal + phase-Z signal	

DA180 series servo drive (100W–1kW)		
Specification		Description
		4: Torque limit signal
Protection	For hardware	Such as protection against overvoltage, undervoltage, overcurrent, overspeed, overload, overheating, encoder fault, and power outage detection.
	For software	Such as protection against ROM fault, initialization fault, I/O distribution exception, and excessive position deviation.
	Fault recording	1: Ten faults can be recorded. 2: Key parameters can be recorded when a fault occurs.
Environment	Working temperature	0–45°C
	Storage temperature	-20–80°C (no frozen)
	Working/storage humidity	≤90%RH (no condensation)
	IP rating	IP20
	Altitude	Below 1000m
	Vibration	≤5.88m/s ² , 10–60Hz (not allowing work at the resonance point)

1.1.2 Outline drawing

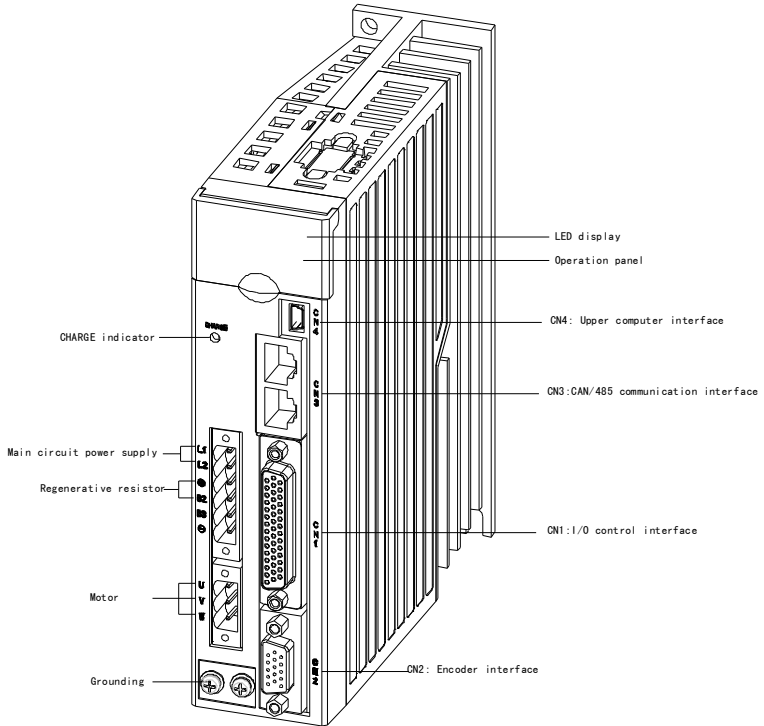

1.1.3 Drive naming

DA180-S 2R8 S G 0

① ② ③ ④ ⑤ ⑥

No.	Description	Example
①	Product category	DA180: Servo drive series
②	Voltage class	S: 220V
③	Rated output current	1R3: 1.3A 1R8: 1.8A 2R8: 2.8A 4R5: 4.5A 5R0: 5.0A 7R6: 7.6A 010: 10A
④	Communication type	S: Support for RS485 and CAN ⁽¹⁾ N: Using EtherCAT bus
⑤	Function category	G: Basic
⑥	Encoder type	0: Absolute type

Note:

⁽¹⁾: For a model without standing inventory, the lead time is longer than usual.

1.1.4 Drive nameplate

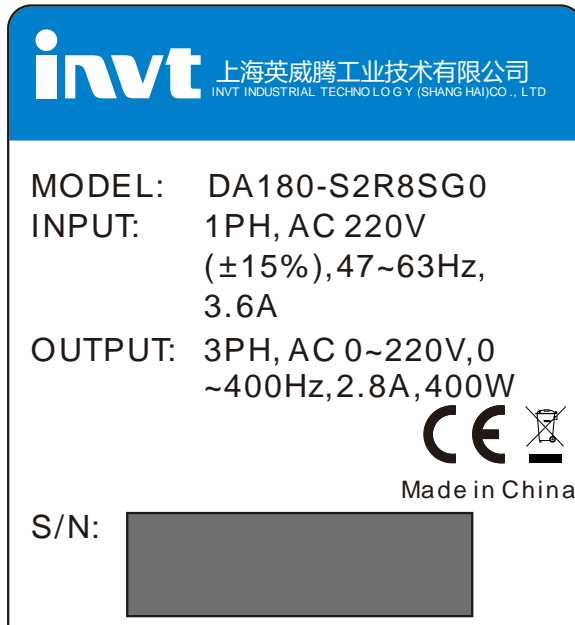

1.1.5 Drive ratings and frame sizes

Model	Input		Output		Frame size
	Voltage (V)	Rated current (A)	Power (kW)	Rated current (A)	
DA180-S1R3	1PH 220	0.9	0.1	1.3	A
DA180-S1R8	1PH 220	1.8	0.2	1.8	A
DA180-S2R8	1PH 220	3.6	0.4	2.8	A
DA180-S4R5	1PH 220	6.8	0.75	4.5	B
DA180-S5R0	1PH 220	9.1	1.0	5	B
DA180-S7R6	3PH 220	5.6	1.5	7.6	C
DA180-S010	3PH 220	7.5	2.0	10	C

1.2 Servo motor

1.2.1 Motor nameplate

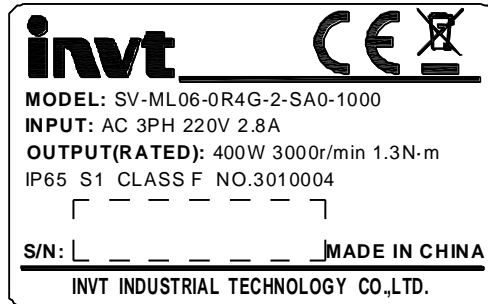

Note: "No. 3010004" in the nameplate indicates the motor model code (motor code for short). Enter this code to the servo parameter P0.00, which is a long parameter and can be set through the keypad. For details, see Step 8 "Set long parameters (with 6 digits at least)" in "Operation flowchart" in section 5.2.1 "Display". Incorrect setting may cause abnormal running of the servo system or even a major fault to the drive and motor.

1.2.2 Motor naming

SV-ML06-0R4G-2-SA0-XXXX

① ② ③ ④ ⑤ ⑥ ⑦ ⑧ ⑨ ⑩ ⑪

No.	Description	Example
①	Product category	SV: Servo system product
②	Product series	M: Series M C: Series C S: Series S
③	Inertia classification	L: Small inertia M: Medium inertia H: Large inertia
④	Base model no.	06: 60mm 08: 80mm 13: 130mm
⑤	Rated power	0R2: 200W 0R4: 400W 0R7: 750W 1R0: 1.0kW 1R5: 1.5kW

No.	Description	Example
		2R0: 2.0kW
⑥	Rated revolutions per minute (RPM)	A: 1000rpm ⁽²⁾ B: 1500rpm E: 2000rpm F: 2500rpm G: 3000rpm
⑦	Voltage class	2: 220VAC
⑧	Encoder type	S: 17-bit single-turn absolute
⑨	Shaft end connection	A: Solid with threaded hole and key (standard) B: Solid plain shaft ⁽¹⁾
⑩	Optional part	0: With oil seal but no brake 1: Without oil seal or brake ⁽¹⁾ 2: With oil seal and permanent magnet brake 3: Without oil seal but with permanent magnet brake ⁽¹⁾ 4: With oil seal and electromagnetic brake ⁽²⁾ 5: Without oil seal but with electromagnetic brake ⁽¹⁾
⑪	Lot no.	Manufacturer lot number ⁽³⁾

Remarks:

⁽¹⁾: For a model without standing inventory, the lead time is longer than usual.

⁽²⁾: When an electromagnetic brake motor is used, since the electromagnetic brake will have backlash, there will be a small clearance (less than $\Phi 0.5^\circ$) in the rotating direction if the motor brake is closed. Pay attention to this in vertical shaft application scenarios. There is no clearance when a permanent magnetic brake is used.

⁽³⁾: Leave it empty for the first-time model selection.

1.3 Cables

1.3.1 Cable nameplate

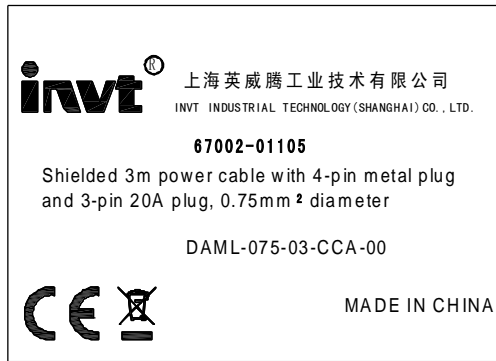

1.3.2 Power cable naming

DAML-075-03-CCA-00

① ② ③ ④ ⑤ ⑥ ⑦ ⑧

No.	Description	Example
①	Product series	Manufacturer use only
②	Power cable	ML: Power cable
③	Cable diameter	075: 0.75mm ² 150: 1.5mm ²
④	Cable length	03: 3 meters 05: 5 meters 10: 10 meters 15: 15 meters 20: 20 meters ...
⑤	Motor connection plug	B: 4-pin regular aviation plug YD28 C: 4-pin metal plug
⑥	Drive connection plug	C: European 3-pin 20A plug 5.08mm E: European 3-pin 20A plug 7.62mm
⑦	Cable material	0: Common cable A: Common shielded cable

No.	Description	Example
		B: Shielded flexible towline cable F: Flexible towline cable
⑧	Serial no.	00: Standard part 01: Serial number for a non-standard part ...

1.3.3 Power cable accessory naming

D①**A**②**M**⑤**L**⑥**-CC**

No.	Description	Example
①	Product series	Manufacturer use only
②	Power cable	ML: Power cable
⑤	Motor connection plug	B: 4-pin regular aviation plug YD28 C: 4-pin metal plug
⑥	Drive connection plug	C: European 3-pin 20A plug 5.08mm E: European 3-pin 20A plug 7.62mm

1.3.4 Encoder cable naming

D①**B**②**E**③**L**④**-06**⑤**-03**⑥**-C0**⑦**-0400**⑧

No.	Description	Example
①	Product series	Manufacturer use only
②	Encoder cable	EL: Encoder cable
③	Number of cores	06: 6-core cable 15: 15-core cable
④	Cable length	03: 3 meters 05: 5 meters 10: 10 meters 15: 15 meters 20: 20 meters ...

No.	Description	Example
⑤	Motor connection plug	B: 15-pin regular aviation plug YD28 C: 9-pin metal plug
⑥	Cable material	0: Common cable F: Flexible towline cable
⑦	Encoder type	04: 17-bit/23-bit absolute
⑧	Serial no.	00: Standard part 01: Serial number for a non-standard part ...

1.3.5 Encoder cable accessory naming

DBEL-CA
①
②
⑤
⑨

No.	Description	Example
①	Product series	Manufacturer use only
②	Encoder cable	EL: Encoder cable
⑤	Motor connection plug	B: 15-pin regular aviation plug YD28 C: 9-pin metal plug
⑨	Drive connection plug	A: 15-pin DB plug

1.3.6 Motor brake cable naming

BRKL-10-A
①
②
③

No.	Description	Example
①	Product series	BRKL: Motor brake cable
②	Cable length	10: 10m
③	Motor connection plug	A: 2-pin metal plug

1.4 Brake resistor specifications

Drive model	Specification of built-in brake resistor	Min. resistance of external brake resistor
DA180-S1R3	/	60Ω
DA180-S1R8	/	60Ω
DA180-S2R8	/	60Ω
DA180-S4R5	45Ω 60W	30Ω
DA180-S5R0	45Ω 60W	30Ω
DA180-S7R6	30Ω 60W	20Ω
DA180-S010	30Ω 60W	20Ω

2**Installation instructions**

2.1 Drive dimensions.....	16
2.1.1 Dimension drawing for frame size A/B.....	16
2.1.2 Models and dimensions.....	16
2.2 Drive installing.....	17
2.2.1 Installation mode	17
2.2.2 Installation directions and clearances.....	18
2.3 Motor outline and mounting dimensions.....	19
2.3.1 For base-60 motors	19
2.3.2 For base-80 motors	19
2.3.3 For base-130 motors	20
2.4 Motor installing.....	20
2.5 Servo-motor technical parameters	21
2.5.1 For motors (using 17-bit single-turn absolute encoders)	21

2.1 Drive dimensions

2.1.1 Dimension drawing for frame size A/B

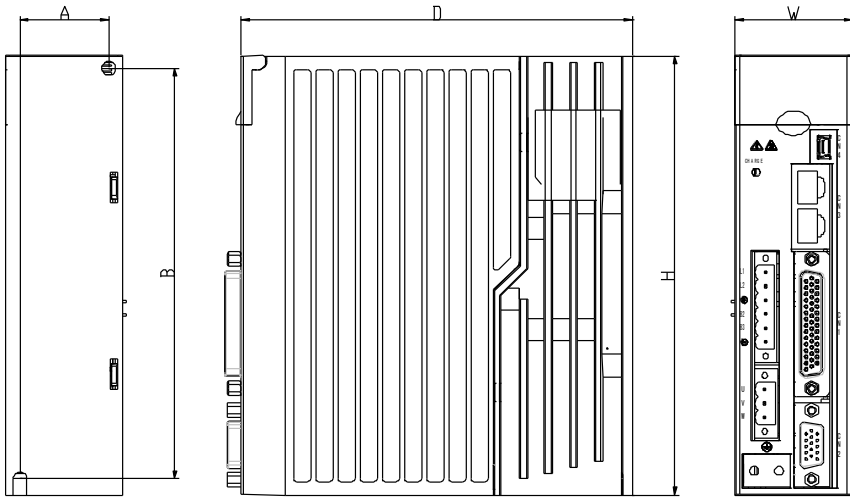

2.1.2 Models and dimensions

Frame size	Model	Outline dimensions			Mount dimensions		Mount hole (mm)
		H (mm)	W (mm)	D (mm)	A (mm)	B (mm)	
A	DA180-S1R3	160	42	141	32	150	M4(Φ5)
	DA180-S1R8						
	DA180-S2R8						
B	DA180-S4R5	160	50	141	40	150	M4(Φ5)
	DA180-S5R0						
C	DA180-S7R6	170	68	180	54	161	M4(Φ5)
	DA180-S010						

2.2 Drive installing

2.2.1 Installation mode

Base installation mode

There is a $\Phi 5$ installation hole at the upper left corner and one at the lower right corner of the rear panel.

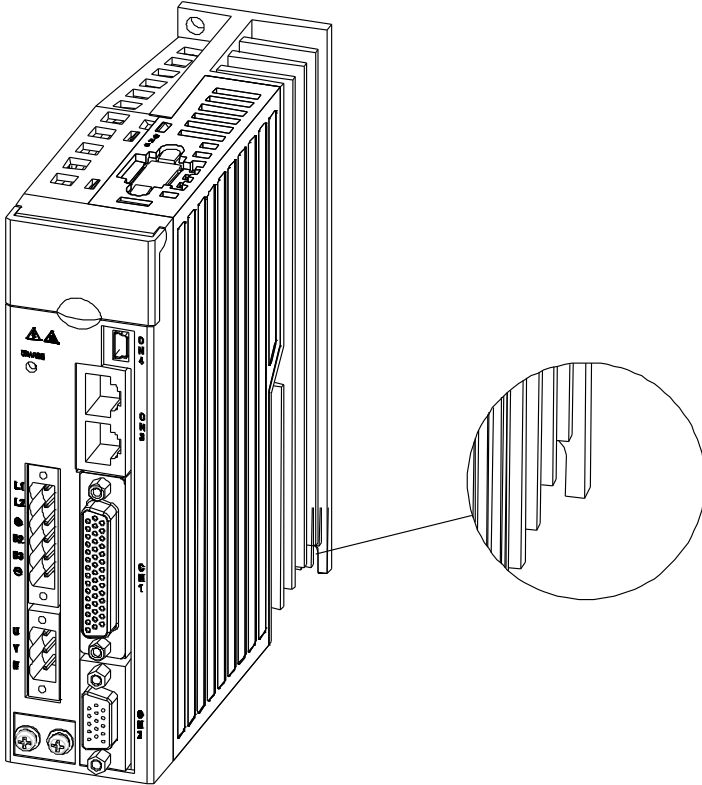

2.2.2 Installation directions and clearances

Install the servo drive vertically and keep enough space for good ventilation. If necessary, install a fan to ensure the temperature inside the control cabinet is lower than 45°C.

Installing one drive

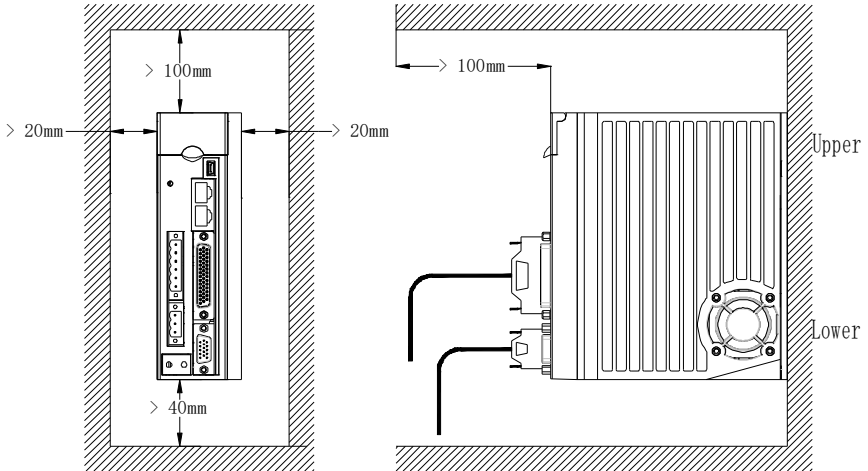

Installing multiple drives

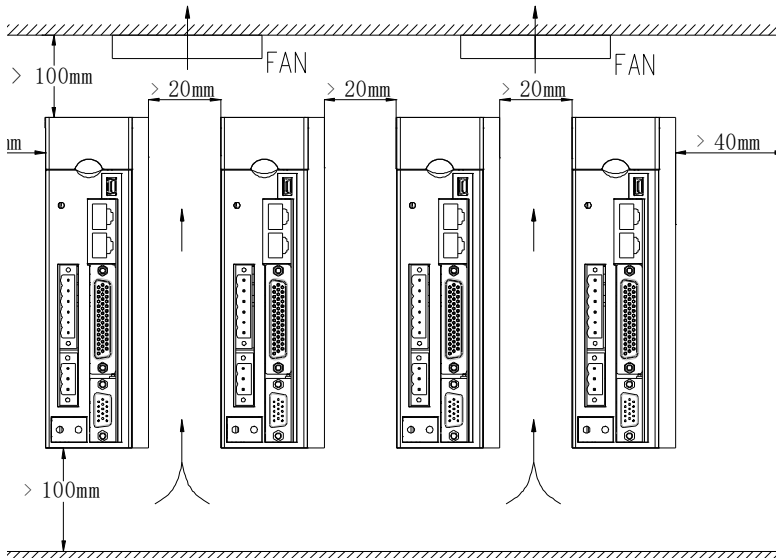

2.3 Motor outline and mounting dimensions

Note: Motor structural dimensions may vary with design modification. If you are sensitive to motor mounting dimensions, check the dimensions with sales staff before ordering. In this section, if not otherwise specified, all the dimensions are expressed in millimeter (mm).

2.3.1 For base-60 motors

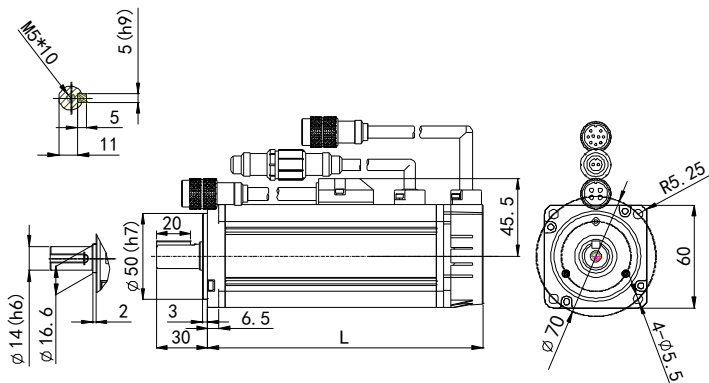

Motor model	L(mm)	
	Without brake	With brake
SV-ML06-0R2G-2-SA□	100.5	137.5
SV-ML06-0R4G-2-SA□	124.5	161.5

2.3.2 For base-80 motors

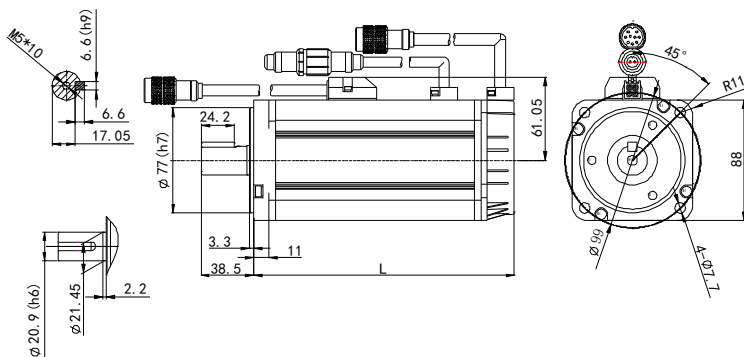

Motor model	L(mm)	
	Without brake	With brake
SV-ML08-0R7G-2-SA□	126.5	173

2.3.3 For base-130 motors

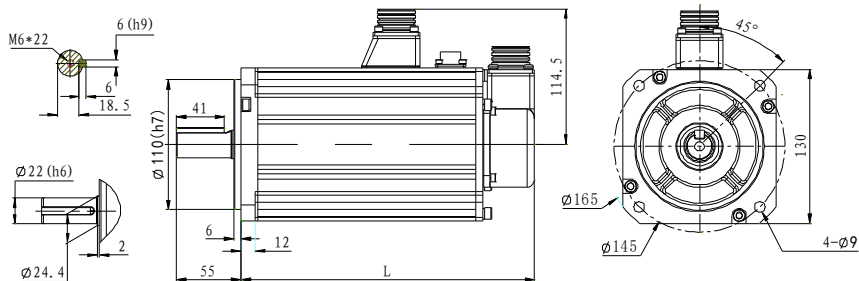

Motor model	L(mm)	
	Without brake	With brake
SV-MM13-1R0E-2-SA□	143	185
SV-MM13-1R5E-2-SA□	159	201
SV-MM13-2R0E-2-SA□	172	217

2.4 Motor installing

- Do not pull the motor leads or output shaft when moving the motor.
- Do not beat or hammer the motor during the motor assembly. Otherwise, the encoder or shaft may be damaged.
- Wipe the anti-rust oil from the motor shaft before use.

2.5 Servo-motor technical parameters

2.5.1 For motors (using 17-bit single-turn absolute encoders)

Motor model	Rated power (kW)	Rated current (A)	Max. transient current (A)	Rated torque (Nm)	Max. transient torque (Nm)	Rated RPM	Max. RPM	Rotation inertia Standard/With permanent magnet brake/With electromagnet brake (kg·cm ²)	Voltage (V)	Weight Standard/With brake (kg)
ML series with small inertia										
SV-ML06-0R2G-2-SA□	0.2	1.5	4.5	0.64	1.92	3000	5000	0.198/0.21	220	1.4/1.6
SV-ML06-0R4G-2-SA□	0.4	2.3	6.9	1.27	3.81			0.33/0.34		1.8/2.0
SV-ML08-0R7G-2-SA□	0.75	4.3	12.9	2.5	7.5			1.28/1.41		3.0/3.5
MM/SM series with medium inertia										
SV-MM13-1R0E-2-SA□	1	4.8	14.4	4.78	14.3	2000	2750	6.4/7.19	220	5.8/7.5
SV-MM13-1R5E-2-SA□	1.5	7.6	22.8	7.16	21.4		2800	9.3/10.09		7.1/8.8
SV-MM13-2R0E-2-SA□	2	9.5	28.5	9.55	28.6		2850	12.2/12.99		8.4/10.1
Insulation class	Class F(155°C)									
IP rating	IP65									
Application environment	Temperature: -20°C—+40°C (non-frozen); RH: below 90% (no condensation)									

3**Wiring instructions**

3.1 System wiring	23
3.1.1 Input power cable requirements	24
3.1.2 Control cable requirements	24
3.1.3 Main circuit cable diameters	25
3.1.4 EMI filter models.....	25
3.2 Main circuit terminal wiring (1PH 220V)	26
3.3 Motor power cable wiring	27
3.3.1 Power cable for base-60/80 motors using absolute encoders	27
3.3.2 Power cable for base-130 motors using absolute encoders	27
3.4 Motor encoder cable wiring	27
3.4.1 Cable for absolute encoder used by base-60/80 motors	27
3.4.2 Cable for absolute encoder used by base-130 motors	28
3.5 Wiring for control I/O terminal CN1	28
3.6 Wiring for encoder terminal CN2	29
3.7 Wiring for RS485/CAN communication terminal CN3	29
3.8 Wiring for USB terminal CN4	30

3.1 System wiring

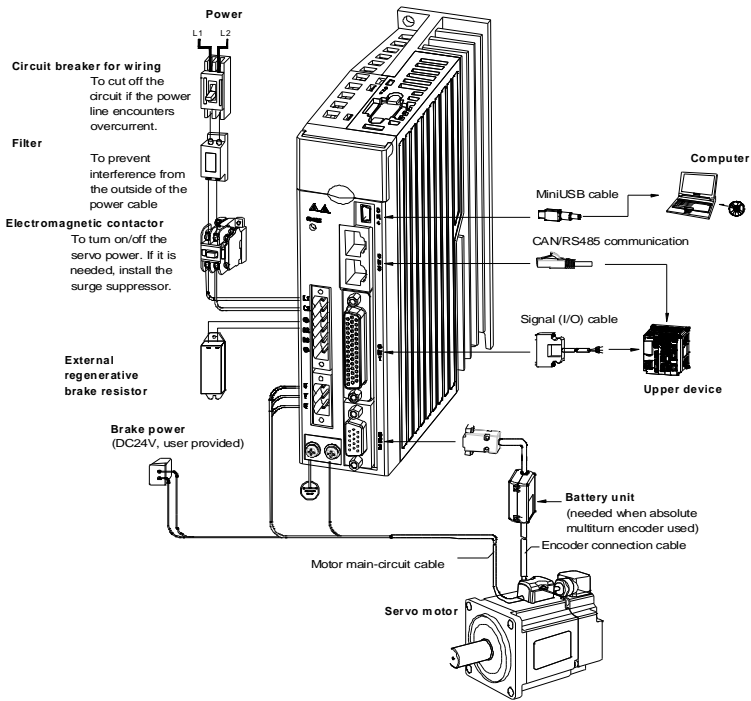

- Before turning on the driver input power, ensure that the input power supply specifications indicated on the nameplate are consistent with those of the grid.
- The electromagnetic contactor is used to switch on or off the main-circuit power supply of the servo drive. Do not use this contactor to start or stop the servo drive.
- In the figure, as the external regenerative brake resistor is connected, the short-connection cable between B2 and B3 must be removed. For details about the connection, see section 3.2 "Main circuit terminal wiring". The resistor must be installed on nonflammable material with good heat dissipation performance, such as metal.

3.1.1 Input power cable requirements

The input power cable dimensions must comply with local regulations.

- The input power cable must be able to withstand the load current.
- The maximum rated temperature margin of the input power cable cannot be lower than 70°C under continuous running.
- The PE grounding conductor and phase conductor are the same in conductivity (since they are the same in cross-sectional area).
- See IEC/EN 61800-3:2004 for EMC requirements.

The shielded four-core cable is recommended as the input power cable.

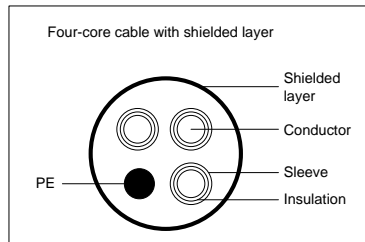

When the shielded cable and phase conductor use the same type of material, in order to protect the conductors properly, the shielded cable and phase conductor must be the same in cross-sectional area, which helps reduce grounding resistance to improve impedance continuity.

To suppress the emission and transmission of RF, the conductivity of the shielded cable must be at least 1/10 of phase conductor conductivity. The shielded-layer coverage rate must be at least 85%.

3.1.2 Control cable requirements

All analog control cables and cables used for frequency input must be shielded cables. Analog signal cable use double-shielded twisted pairs (shown in figure a). Each type of signal occupies an independent shielded twisted pair. Different types of analog signal must occupy different grounding wires.

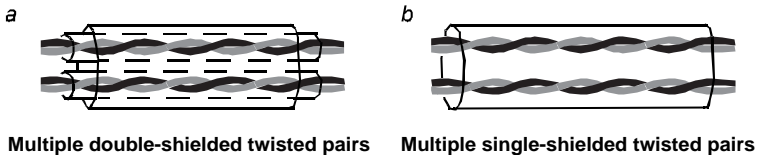

For low voltage digital signals, double-layer shielded cables are recommended, though unshielded pairs or single-shielded pairs (shown in figure b) can be used. However, for pulse input signals, only shielded cables can be used. Only shielded twisted pairs can be used as communication cables.

3.1.3 Main circuit cable diameters

Main circuit cable diameters for models in the small power range (100W–1kW)								
Drive model	Recommended cable diameter (mm ²)			Connectable cable diameter (mm ²)			Terminal screw size	Tightening torque (Nm)
	L1\L2\L3 UVW	PE	L1C\L2C	L1\L2\L3 UVW	(+), B2, B3, (-)	PE		
DA180-S1R3	0.75	0.75	0.75	0.75~4	0.75~4	0.75~4	M2.5	0.3~0.6
DA180-S1R8								
DA180-S2R8								
DA180-S4R5								
DA180-S5R0	1.5	1.5	0.75	1.5~4	1.5~4	1.5~4	M2.5	0.3~0.6
DA180-S7R6								
DA180-S010								

3.1.4 EMI filter models

Drive model	EMI filter model
DA180-S1R3	FLT-P04006L-B
DA180-S1R8	
DA180-S2R8	
DA180-S4R5	
DA180-S5R0	FLT-P04016L-B
DA180-S7R6	
DA180-S010	

Note: The EMI filter models in the table are INVT models. The EMI filter is used at the power input end.

3.2 Main circuit terminal wiring (1PH 220V)

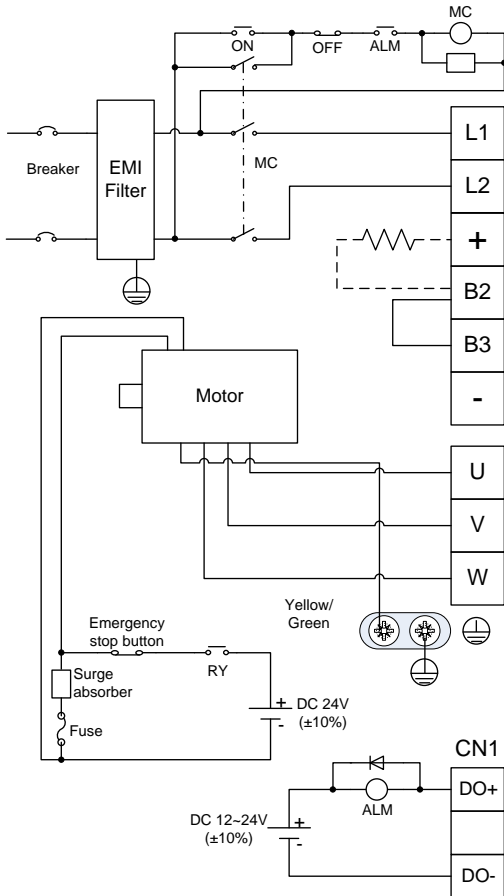

- Employ this emergency stop circuit.
- Add a surge absorber to each end of the electromagnetic contactor coil.
- Input voltage of power: AC 220V(-15%)-240V(+10%)
- Keep the cable for connecting B2 and B3 in place unless an external regenerative brake resistor is used.
- If you use an external regenerative brake resistor, remove the connection cable between B2 and B3 and connect the resistor as shown in the dashed box.
- Connect the servo motor cables to the drive output terminals U, V, and W according to the correct phase sequence. Incorrect phase sequence may cause a drive fault.
- Ground the servo drive properly. Otherwise, electrical shocks may be caused.
- Prepare the 24VDC power for electromagnetic braking by yourself and isolate it from the DC12~24V power for signal control.
- Pay attention to free-wheeling diode connection. Reversed polarity may cause drive damage.

3.3 Motor power cable wiring

3.3.1 Power cable for base-60/80 motors using absolute encoders

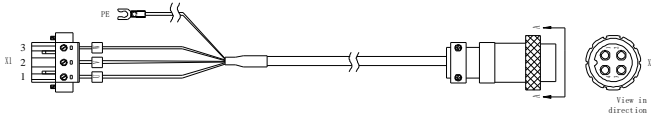

Wiring mapping			
Definition	X1	X2	Core wire color
U	X1.1	X2.4	Blue
V	X1.2	X2.3	Red
W	X1.3	X2.1	Brown
PE	Ground terminal	X2.2	Yellow/green + shield

3.3.2 Power cable for base-130 motors using absolute encoders

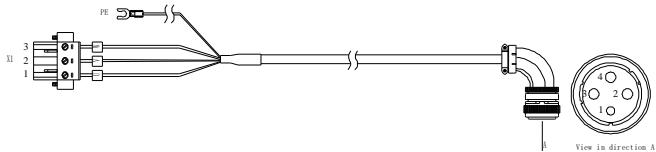

Wiring mapping			
Definition	X1	X2	Core wire color
U	X1.1	X2.2	Blue
V	X1.2	X2.3	Red
W	X1.3	X2.4	Brown
PE	Ground terminal	X2.1	Yellow/green + shield

3.4 Motor encoder cable wiring

3.4.1 Cable for absolute encoder used by base-60/80 motors

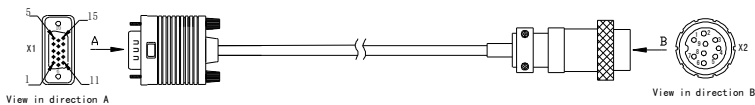

Wiring mapping			
Signal	X1	X2	Core wire color
SD+	X1.1	X2.1	Twisted pair

Wiring mapping			
Signal	X1	X2	Core wire color
SD-	X1.7	X2.2	Twisted pair
5V	X1.5	X2.3	
GND	X1.12	X2.4	
VB-3.6V	/	X2.5	Twisted pair
VB-GND	/	X2.6	
PE	Metal shell	Metal shell	Woven

3.4.2 Cable for absolute encoder used by base-130 motors

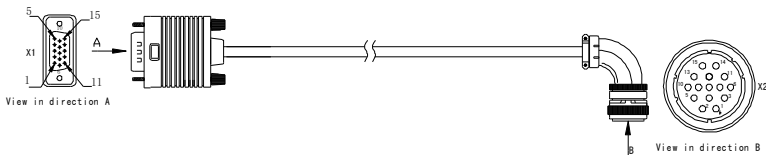

Wiring mapping			
Signal	X1	X2	Core wire color
SD+	X1.1	X2.2	Twisted pair
SD-	X1.7	X2.3	
5V	X1.5	X2.4	
GND	X1.12	X2.5	Twisted pair
VB-3.6V	/	X2.6	
VB-GND	/	X2.7	Twisted pair
PE	Metal shell	X2.1	

3.5 Wiring for control I/O terminal CN1

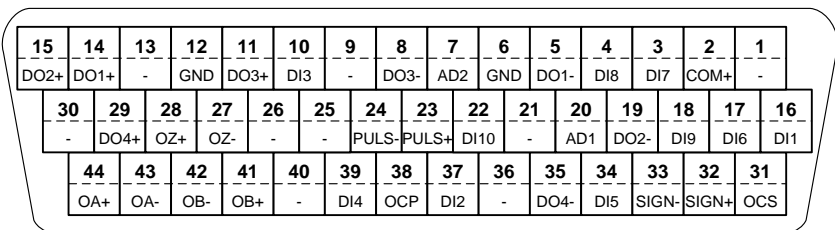

CN1 plug pins and signal codes

Note: This is the interface definition for the standard model. For details about the terminal functions and applications, see chapter 4 “Control modes”.

3.6 Wiring for encoder terminal CN2

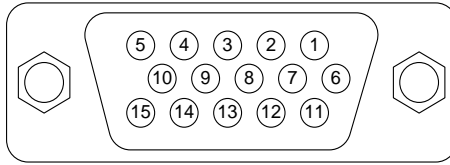

CN2 functions			
Pin	Name	Function	Remarks
1	V+ /SD+	Serial encoder data+	Only serial encoders are supported.
5	5V	Encoder power supply	
7	V- /SD-	Serial encoder data-	
12	GND	Power ground	
15	-	Unused	

3.7 Wiring for RS485/CAN communication terminal CN3

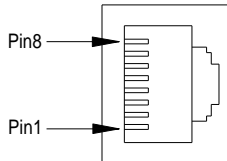

CN3 functions			
Pin	Name	Function	Remarks
1	GND_CAN	Power ground for CAN chip	The same interface is provided for RS485 and CAN communication. Each signal occupies two pins, for easy multidevice networking.
2	GND_485	Power ground for RS485 chip	
4	RS485+	RS485 data+	
5	RS485-	RS485 data-	
7	CAN_L	CAN data-	
8	CAN_H	CAN data+	
3, 6	-	Unused	

Note: This terminal is available only in the models with the CANopen function. If the drive uses the EtherCAT bus, this port is the standard network cable port, which indicates that pin 1, pin 2, pin 3, and pin 6 correspond to Tx+, Tx-, Rx+, and Rx- respectively.

3.8 Wiring for USB terminal CN4

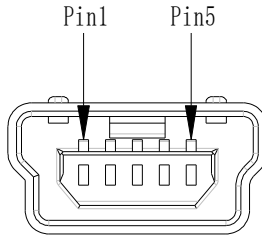

CN4 functions			
Pin	Name	Function	Remarks
2	D-	Data-	The standard cable for converting mini USB to USB-A can be used.
3	D+	Data +	
5	GND	Signal ground	
1, 4	-	Unused	

4**Control modes**

4.1 Standard wiring diagram for position control	32
4.2 Standard wiring diagram for speed control	33
4.3 Standard wiring diagram for torque control	34
4.4 CN1 function description	35
4.4.1 CN1 pins.....	35
4.4.2 CN1 pin functions	35
4.4.3 Power signals	36
4.4.4 Default digital settings in different modes	36
4.4.5 Pulse input signals and functions	50
4.4.6 Analog input signals and functions	50
4.4.7 Encoder output signals and functions.....	50
4.5 Wiring description for CN1	51
4.5.1 Digital input circuit wiring	51
4.5.2 Pulse input circuit wiring	51
4.5.3 Analog input circuit wiring	53
4.5.4 Digital output circuit wiring.....	54
4.5.5 Frequency-division output circuit wiring of encoder feedback signals	54
4.5.6 Electromagnetic brake wiring	55

4.1 Standard wiring diagram for position control

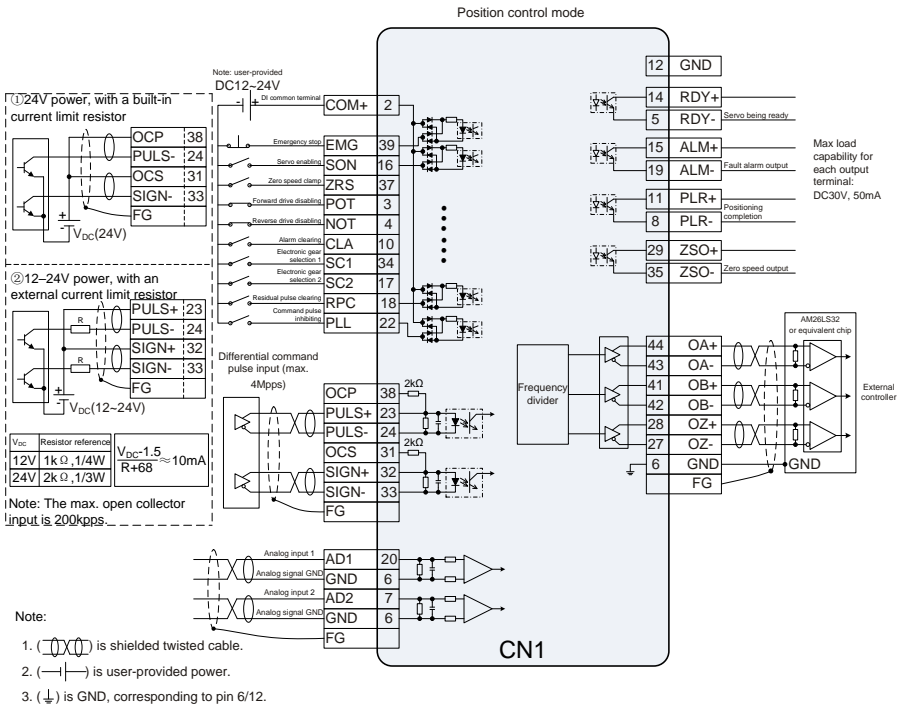

4.2 Standard wiring diagram for speed control

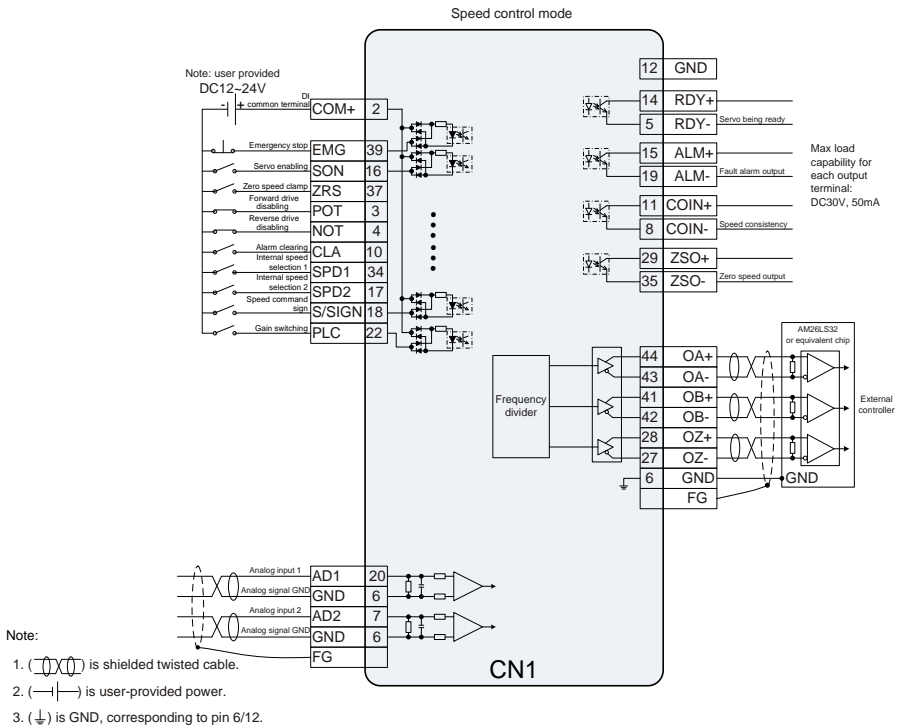

4.3 Standard wiring diagram for torque control

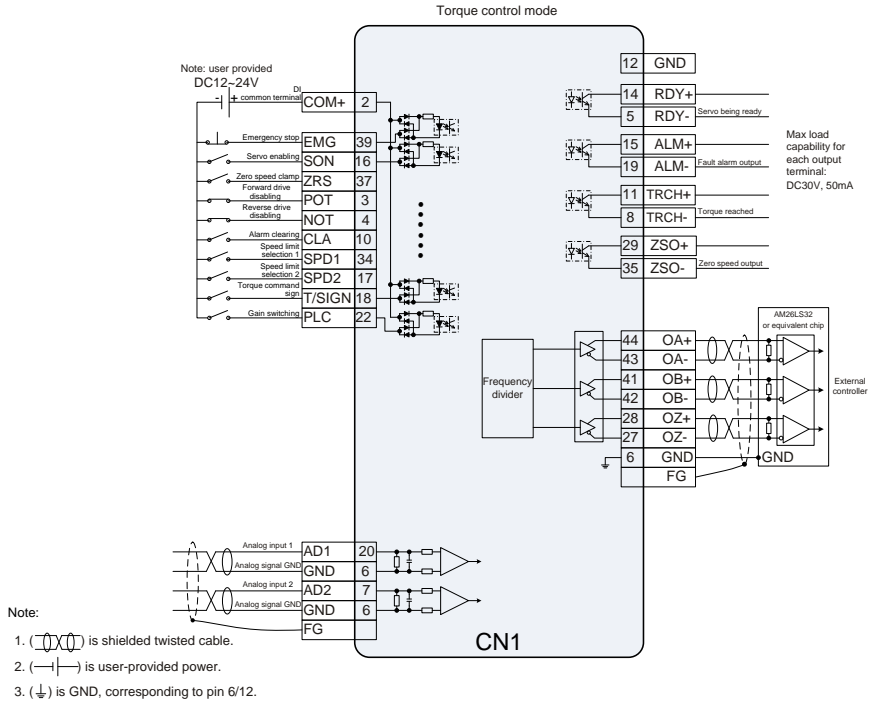

4.4 CN1 function description

4.4.1 CN1 pins

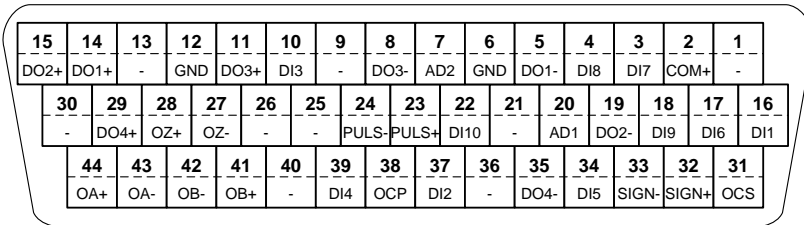

CN1 plug pins and signal codes

4.4.2 CN1 pin functions

Pin	Sign	Function	Pin	Sign	Function
1	-	Unused	23	PULS+	Differential command pulse +
2	COM+	Common DI input port	24	PULS-	Differential command pulse -
3	DI7	Digital input 7	25	-	Unused
4	DI8	Digital input 8	26	-	Unused
5	DO1-	Digital output 1-	27	OZ-	Phase-Z differential output -
6	GND	Signal ground	28	OZ+	Phase-Z differential output +
7	AD2	Analog input 2	29	DO4+	Digital output 4+
8	DO3-	Digital output 3-	30	-	Unused
9	-	Unused	31	OCS	Open collector command direction
10	DI3	Digital input 3	32	SIGN+	Differential command direction +
11	DO3+	Digital output 3+	33	SIGN-	Differential command direction -
12	GND	Signal ground	34	DI5	Digital input 5
13	-	Unused	35	DO4-	Digital output 4-
14	DO1+	Digital output 1+	36	-	Unused
15	DO2+	Digital output 2+	37	DI2	Digital input 2
16	DI1	Digital input 1	38	OCP	Open collector command pulse
17	DI6	Digital input 6	39	DI4	Digital input 4
18	DI9	Digital input 9	40	-	-
19	DO2-	Digital output 2-	41	OB+	Phase-B differential output +
20	AD1	Analog input 1	42	OB-	Phase-B differential output -
21	-	Unused	43	OA-	Phase-A differential output -
22	DI10	Digital input 10	44	OA+	Phase-A differential output +

4.4.3 Power signals

Sign	Pin	Name	Function
GND	6, 12	Signal ground	Ground for analog input signals and A/B/Z frequency division output signals
COM+	2	Common DI input port	<ul style="list-style-type: none"> If DI is active low (0V), COM+ connects to the positive polarity of the external 12V–24V power. If DI is active high (12V–24V), COM+ connects to the reference ground of the external 12V–24V power.
FG	Housing	Housing ground	The CN1 terminal housing connects to the drive housing.

4.4.4 Default digital settings in different modes

Sign	Pin	Name	Position mode			Speed mode		
			Default	Symbol	Function	Default	Symbol	Function
DI1	16	Digital input 1	0x003	SON	Enabling servo	0x003	SON	Enabling servo
DI2	37	Digital input 2	0x00D	ZRS	Zero-point clamping	0x00D	ZRS	Zero-point clamping
DI3	10	Digital input 3	0x004	CLA	Clearing alarms	0x004	CLA	Clearing alarms
DI4	39	Digital input 4	0x016	EMG	Emergency stop	0x016	EMG	Emergency stop
DI5	34	Digital input 5	0x019	SC1	Numerator selection for electronic gear ratio	0x00A	SPD1	Internal speed command selection 1
DI6	17	Digital input 6	0x01A	SC2	Numerator selection 2 for electronic gear ratio	0x00B	SPD2	Internal speed command selection 2
DI7	3	Digital input 7	0x001	POT	Disabling forward drive	0x001	POT	Disabling forward drive
DI8	4	Digital input 8	0x002	NOT	Disabling reverse drive	0x002	NOT	Disabling reverse drive
DI9	18	Digital input 9	0x007	RPC	Clearing residual pulses	0x00E	S-SIGN	Speed command sign
DI10	22	Digital input 10	0x008	PLL	Inhibiting command pulses	0x006	PLC	Switching gains
DO1	14/5	Digital output	0x001	RDY	Servo	0x001	RDY	Servo

Sign	Pin	Name	Position mode			Speed mode		
			Default	Symbol	Function	Default	Symbol	Function
		1			readiness output			readiness output
DO2	15/19	Digital output 2	0x003	ALM	Fault output	0x003	ALM	Fault output
DO3	11/8	Digital output 3	0x007	PLR	Position completion	0x009	COIN	Speed consistency
DO4	29/35	Digital output 4	0x00D	ZSO	Zero-speed output	0x00D	ZSO	Zero-speed output
DO5	9/26	Digital output 5	0x005	BRK	Electromagnetic brake release signal	0x005	BRK	Electromagnetic brake release signal
DO6	13/30	Digital output 6	0x00E	LM	Torque being limited	0x00E	LM	Torque being limited

Sign	Pin	Name	Torque mode		
			Default	Symbol	Function
DI1	16	Digital input 1	0x003	SON	Enabling servo
DI2	37	Digital input 2	0x00D	ZRS	Zero-point clamping
DI3	10	Digital input 3	0x004	CLA	Clearing alarms
DI4	39	Digital input 4	0x016	EMG	Emergency stop
DI5	34	Digital input 5	0x00A	SPD1	Internal speed command selection 1
DI6	17	Digital input 6	0x00B	SPD2	Internal speed command selection 2
DI7	3	Digital input 7	0x001	POT	Disabling forward drive
DI8	4	Digital input 8	0x002	NOT	Disabling reverse drive
DI9	18	Digital input 9	0x00F	T-SIGN	Torque command sign
DI10	22	Digital input 10	0x006	PLC	Switching gains
DO1	14/5	Digital output 1	0x001	RDY	Servo readiness output
DO2	15/19	Digital output 2	0x003	ALM	Fault output
DO3	11/8	Digital output 3	0x010	TRCH	Torque reaching
DO4	29/35	Digital output 4	0x00D	ZSO	Zero-speed output
DO5	9/26	Digital output 5	0x005	BRK	Electromagnetic release signal
DO6	13/30	Digital output 6	0x00E	LM	Torque being limited

4.4.4.1 Digital input functions

Signal	Symbol	Function	Applicable mode		
			P	S	T
Disabling forward drive	POT	0x01	P	S	T
Disabling reverse drive	NOT	0x02	P	S	T
<p>Signal of disabling the drive to the forward or reverse direction. The detailed action is associated with the setting of P3.40 [Disable travel limit switch].</p> <p>If P3.40 is set to 0:</p> <ul style="list-style-type: none"> When the input of forward drive disabling is valid, the motor stops at the current position and accepts the reverse command input only. When the input of reverse drive disabling is valid, the motor stops at the current position and accepts the forward command input only. <p>If P3.40 is set to 1, this function is invalid.</p> <p>If P3.40 is set to 2 when the input of forward or reverse direction drive disabling is valid, the drive alarms.</p>					

Signal	Symbol	Function	Applicable mode		
			P	S	T
Enabling servo	SON	0x03	P	S	T
<p>Signal of controlling whether to enable servo.</p> <p>If it is valid, the drive powers on the motor. If it is invalid, the drive powers off the motor.</p>					

Signal	Symbol	Function	Applicable mode		
			P	S	T
Clearing alarms	CLA	0x04	P	S	T
<p>Signal of controlling whether to clear an alarm after the drive reports the alarm.</p> <p>It may not be used to clear some alarms. For details, see section 10.4 "Fault codes".</p>					

Signal	Symbol	Function	Applicable mode		
			P	S	T
Switching control modes	MCH	0x05	P	S	T
<p>If P0.03 [Control mode] is set to 3, 4, or 5, the signal specifies control mode switching. Control mode switching is valid in enabled state.</p> <p>If the control mode is set to 0, 1, 2, 6, or 7, it is invalid.</p>					

Signal	Symbol	Function	Applicable mode		
Switching gains	PLC	0x06	P	S	T
Signal of controlling the switching between the first gain and second gain.					

Signal	Symbol	Function	Applicable mode		
Clearing residual pulses	RPC	0x07	P		
Control signal of clearing residual pulses. The detailed action is associated with the setting of P3.45 [Residual pulse clearing mode]. If P3.45 is set to 0, which indicates electrical-level clearing, residual pulses are always 0 when this digital input is valid. If P3.45 is set to 1, which indicates rising-edge clearing, residual pulses are cleared only once when the digital input changes from 0 to 1.					

Signal	Symbol	Function	Applicable mode		
Inhibiting command pulses	PLL	0x08	P		
Signal of controlling whether to suspend receiving command pulse input. The detailed action is associated with the setting of P3.44 [Disable command pulse inhibition]. If P3.44 is set to 0, the function takes effect. When the digital input is valid, the drive suspends receiving command pulse input. If P3.44 is set to 1, the function is invalid.					

Signal	Symbol	Function	Applicable mode		
Switching torque limits	TLC	0x09	P	S	
Signal of controlling the switching between the first torque limit and second torque limit. For the settings and switching methods of various torque limits, see P0.09 [Torque limit mode].					

Signal	Symbol	Function	Applicable mode	
Internal-speed command 1	SPD1	0x0A	S	T
Internal-speed command 2	SPD2	0x0B	S	T
Internal-speed command 3	SPD3	0x0C	S	

Signals of selecting from internal-speed commands 1 to 8 or from internal speed limits 1 to 4.

Control mode	Setting of P0.40	SPD3	SPD2	SPD1	Associated parameter and setting
Speed mode	0	0	0	0	P0.46, internal speed 1
		0	0	1	P0.47, internal speed 2
		0	1	0	P0.48, internal speed 3
		0	1	1	P0.49, internal speed 4
		1	0	0	P0.50, internal speed 5
		1	0	1	P0.51, internal speed 6
		1	1	0	P0.52, internal speed 7
Torque mode	0	0	0	0	P0.46, speed limit 1
		0	0	1	P0.47, speed limit 2
		0	1	0	P0.48, speed limit 3
		0	1	1	P0.49, speed limit 4

Signal	Symbol	Function	Applicable mode	
Zero-point clamping	ZRS	0x0D	S	T

Signal of controlling zero-point clamping. The detailed action is associated with the setting of P0.58 [Zero-point clamping mode]. For details, see the description for P0.58.

Signal	Symbol	Function	Applicable mode	
Speed command sign	S-SIGN	0x0E	S	

Signal of selecting the sign for speed command input in speed mode.

If P0.41 [Speed command direction setting] is set to 1, this digital input takes effect. If P0.41 is set to 0, it does not take effect.

Signal	Symbol	Function	Applicable mode	
Torque command sign	T-SIGN	0x0F		T

Signal of selecting the sign for torque command input in torque control mode.

If P0.61 [Torque command direction setting] is set to 1, this digital input takes effect, If P0.61 is set to 0, it does not take effect.

Signal	Symbol	Function	Applicable mode		
Internal position command 1	POS1	0x10	P		
Internal position command 2	POS2	0x11	P		
Internal position command 3	POS3	0x12	P		
Internal position command 4	POS4	0x13	P		
Internal position command 5	POS5	0x20	P		
Internal position command 6	POS6	0x21	P		
Internal position command 7	POS7	0x22	P		

These signals are used to select from position commands 0–127 in point-to-point (PTP) control mode, with the same function as P5.20 [PTP trigger signal] in bus control mode. They are valid only when P0.20 [Position command source] is set to 2.

The combination of 7 digital inputs is used to select the different PTP position of PtP0.00–PtP2.55 and the corresponding target speed, ACC/DEC time and the delay time of P5.21–P5.68.

Control mode	POS7	POS6	POS5	POS4	POS3	POS2	POS1	Associated parameter and setting
Position	0	0	0	0	0	0	0	PtP0.01[Position of segment 00]
	0	0	0	0	0	0	1	PtP0.03[Position of segment 01]
	0	0	0	0	0	1	0	PtP0.05[Position of segment 02]
	0	0	0	0	0	1	1	PtP0.07[Position of segment 03]
	0	0	0	0	1	0	0	PtP0.09[Position of segment 04]
	0	0	0	0	1	0	1	PtP0.11[Position of segment 05]
	0	0	0	0	1	1	0	PtP0.13[Position of segment 06]
	0	0	0	0	1	1	1	PtP0.15[Position of segment 07]
	0	0	0	1	0	0	0	PtP0.17[Position of segment 08]
	0	0	0	1	0	0	1	PtP0.19[Position of segment 09]
0	0	0	1	0	1	0	PtP0.21[Position of segment 10]	

	0	0	0	1	0	1	1	PtP0.23[Position of segment 11]
	0	0	0	1	1	0	0	PtP0.25[Position of segment 12]
	x	x	x	x	x	x	x	xxx
		1	1	1	1	1	0	PtP2.53[Position of segment 126]
	1	1	1	1	1	1	1	PtP2.55[Position of segment 127]

Signal	Symbol	Function	Applicable mode		
External fault	EXT	0x14	P	S	T
Signal of reporting an external fault alarm. If this digital input is valid, the drive reports the alarm Er10-3 and stops.					

Signal	Symbol	Function	Applicable mode		
Switching inertia ratios	JC	0x15	P	S	T
Signal of controlling the switching between the first inertia ratio and second inertia ratio. If this digital input is valid, the internal software uses P1.02. If it is invalid, the internal software uses P1.01.					

Signal	Symbol	Function	Applicable mode		
Emergency stop	EMG	0x16	P	S	T
Signal of controlling emergency stop. If P3.41 [Disable emergency stop] is set to 0 and this digital input is valid, the drive stops and report the alarm Er10-4.					

Signal	Symbol	Function	Applicable mode		
Home switch input	HOME	0x17	P		
Input signal of the Home switch. When the drive executes the homing action in some homing mode, , the drive completes the homing action if this digital input is valid. For details, see the description for P5.10 [Homing mode].					

Signal	Symbol	Function	Applicable mode		
Homing trigger	HTRG	0x18	P		
<p>Signal of controlling the triggering of homing which is led by the drive. It is valid in the rising edge. This digital input has no relation with bus control. P5.15 [Homing trigger command] has the same function.</p>					

Signal	Symbol	Function	Applicable mode																								
Numerator selection 1 for electronic gear ratio	SC1	0x19	P																								
Numerator selection 2 for electronic gear ratio	SC2	0x1A	P																								
<p>This group of signal is used to switch between a maximum of four electronic gear ratios. Before using this function group, set P0.22 [Pulses per motor resolution] to 0 and then set numerators (P0.25–P0.29).</p> <p>Note: If the electronic gear ratio is switched through digital input, P4.10 [Upper computer type] must be 0.</p>																											
		<table border="1"> <thead> <tr> <th rowspan="2">SC1</th> <th rowspan="2">SC2</th> <th colspan="2">Electronic gear ratio</th> </tr> <tr> <th>Numerator</th> <th>Denominator</th> </tr> </thead> <tbody> <tr> <td>0</td> <td>0</td> <td>P0.25</td> <td>P0.26</td> </tr> <tr> <td>1</td> <td>0</td> <td>P0.27</td> <td>P0.26</td> </tr> <tr> <td>0</td> <td>1</td> <td>P0.28</td> <td>P0.26</td> </tr> <tr> <td>1</td> <td>1</td> <td>P0.29</td> <td>P0.26</td> </tr> </tbody> </table>				SC1	SC2	Electronic gear ratio		Numerator	Denominator	0	0	P0.25	P0.26	1	0	P0.27	P0.26	0	1	P0.28	P0.26	1	1	P0.29	P0.26
SC1	SC2	Electronic gear ratio																									
		Numerator	Denominator																								
0	0	P0.25	P0.26																								
1	0	P0.27	P0.26																								
0	1	P0.28	P0.26																								
1	1	P0.29	P0.26																								

Signal	Symbol	Function	Applicable mode		
PTP control trigger	TRIG	0x1B	P		
<p>In PTP control mode, it works with the position commands 1–4 to trigger target position switching. It is valid in the rising edge.</p> <p>During the use, the target position is selected through the internal position commands 1–4, and then the rising edge of this digital input triggers the switching.</p>					

Signal	Symbol	Function	Applicable mode		
Vibration control switching input	VS-SEL	0x1C	P		
<p>Signal of controlling the switching between the first vibration control frequency and second vibration control frequency.</p> <p>If this digital input is valid, the internal software uses P1.38 [Vibration control frequency 2] and</p>					

Signal	Symbol	Function	Applicable mode		
associated parameters. If it is invalid, the internal software uses P1.36 [Vibration control frequency 1] and associated parameters.					

Signal	Symbol	Function	Applicable mode		
Quick stop	Q-STOP	0x1D	P	S	T
Signal of externally controlling quick stop. If this digital input is valid, the control motor of the drive decelerates from current speed to 0 according to the regular curve set by P0.69 [DEC time for quick stop]. If it changes from valid to invalid, the motor restores to the state prior to quick stop.					
Signal	Symbol	Function	Applicable mode		
PTP control stop	PTP-ST	0x1E	P		
Signal of controlling whether to stop PTP running in PTP mode, valid in the rising edge. In bus control mode, if P5.20 [PTP trigger signal] is set to 2048, the same function can be achieved also.					

Signal	Symbol	Function	Applicable mode		
Clearing absolute position	PCLR	0x1F	P		
Signal of clearing the multiturn absolute encoder. If this digital input is valid, the multiturn data is clear while the single-turn data remains unchanged, but the absolute position in the feedback is cleared.					

Signal	Symbol	Function	Applicable mode		
Forward jogging	FJOG	0x23	P		
If this digital input is valid, the motor executes forward jogging.					

Signal	Symbol	Function	Applicable mode		
Reverse jogging	RJOG	0x24	P		
If this digital input is valid, the motor executes reverse jogging.					

Signal	Symbol	Function	Applicable mode		
Switching high/low jogging speed	JOGC	0x25	P		
Signal of switching between the high jogging speed and low jogging speed. If this digital input is					

valid, the drive jogs at high speed.					
Signal	Symbol	Function	Applicable mode		
Enabling terminal jogging	DJOG	0x2C	P		
If this digital input is valid, terminal jogging is valid.					

Signal	Symbol	Function	Applicable mode		
Gantry synchronization cancellation input	GIN	0x2D	P		
If this digital input is valid, gantry synchronization is cancelled.					

Signal	Symbol	Function	Applicable mode		
Master gantry synchronization alignment sensor	GSM	0x2E	P		
Signal used by the master gantry synchronization alignment sensor.					

Signal	Symbol	Function	Applicable mode		
Slave gantry synchronization alignment sensor	GSS	0x2F	P		
Signal is used by the slave gantry synchronization alignment sensor.					

Signal	Symbol	Function	Applicable mode		
Dynamic brake relay feedback	DBS	0x30	P	S	T
If this digital input is valid, the dynamic brake relay is closed.					

Signal	Symbol	Function	Applicable mode		
Auto/manually switching turrets	DAT	0x31	P		
If this digital input is valid, the turret runs in manual mode.					

Signal	Symbol	Function	Applicable mode		
Turret forward jogging	DFJ	0x32	P		
If this digital input is valid, the turret jogs forward.					

Signal	Symbol	Function	Applicable mode		
Turret reverse jog	DRJ	0x33	P		
If this digital input is valid, the turret jogs reversely.					

Signal	Symbol	Function	Applicable mode		
Magnetic pole check	PDET	0x34	P		
If this digital input is valid, the magnetic pole is checked.					

4.4.4.2 Digital output functions

Signal	Symbol	Function	Applicable mode		
Servo readiness output	RDY	0x01	P	S	T
This signal indicates that the drive is ready. If it is valid, the drive is enabled to power on the motor. If it is invalid, the drive does not respond to the servo enabling command.					

Signal	Symbol	Function	Applicable mode		
Servo running output	RUN	0x02	P	S	T
This signal indicates that the drive is enabled. If it is valid, the motor is powered on.					

Signal	Symbol	Function	Applicable mode		
Fault output	ALM	0x03	P	S	T
This signal indicates that the drive reports a fault alarm. If it is valid, the drive encounters a fault.					

Signal	Symbol	Function	Applicable mode		
Electromagnetic brake release	BRK	0x05	P	S	T
This signal outputs the release of the electromagnetic brake. If it is valid, the brake is released, and the motor control command is received. If it is invalid, the brake is disconnected.					

Signal	Symbol	Function	Applicable mode		
Position command existence	PCMD	0x06	P		
This signal outputs whether there is a position command. If it is valid, there is a non-zero position command which executes motor control.					

Signal	Symbol	Function	Applicable mode		
Positioning completion	PLR	0x07	P		
This signal outputs positioning is completed. If it is valid, the positioning is completed.					

Signal	Symbol	Function	Applicable mode		
Control mode switching status	MCHS	0x08	P	S	T
This signal indicates the switching between different control modes. If it is valid, control mode 1 is switched to control mode 2. This function output becomes invalid when control mode 2 is switched to control mode 1.					

Signal	Symbol	Function	Applicable mode		
Speed consistency	COIN	0x09	P	S	T
This signal outputs speed consistency. If it is valid, the speed difference between the current speed feedback and speed command falls in the setting of P3.53 [Speed consistency range].					

Signal	Symbol	Function	Applicable mode		
Speed reaching	SR	0x0A	P	S	T
It is the status signal which outputs that the speed is reached. If it is valid, the current speed feedback reaches the setting of P3.54 [Speed reaching range].					

Signal	Symbol	Function	Applicable mode		
Speed being limited	SL	0x0B			T
This signal outputs the speed is being limited. If it is valid, in torque mode, the current torque output does not match the torque command, but the speed feedback reaches the speed limit setting.					

Signal	Symbol	Function	Applicable mode		
Speed command existence	SCMD	0x0C	P	S	T
This signal outputs whether there is a speed command. If it is valid, there is a non-zero speed command which executes motor control.					

Signal	Symbol	Function	Applicable mode		
Zero-speed output	ZSO	0x0D	P	S	T
This signal outputs whether the current speed feedback is zero.					

Signal	Symbol	Function	Applicable mode		
Torque being limited	LM	0x0E	P	S	T
This signal outputs the torque is being limited. If it is valid, the current torque output reaches the maximum torque limit.					

Signal	Symbol	Function	Applicable mode		
Homing completion	HEND	0x0F	P		
This signal outputs homing is completed. If it is valid, the homing led by the drive is completed.					

Signal	Symbol	Function	Applicable mode		
Torque reaching	TRCH	0x10			T
This signal outputs torque reaching. If it is valid, the difference between the current torque output and torque command falls in the setting of P3.59 [Torque reaching range]. The detection may lag by 5%.					

Signal	Symbol	Function	Applicable mode		
PTP reaching	PTPF	0x16	P		
This signal outputs PTP is reaching.					

Signal	Symbol	Function	Applicable mode		
PTP output 1	PTPO1	0x17	P		
It is the signal of PTP output 1.					

Signal	Symbol	Function	Applicable mode		
PTP output 2	PTPO2	0x18	P		
It is the signal of PTP output 2.					

Signal	Symbol	Function	Applicable mode		
PTP output 3	PTPO3	0x19	P		
It is the signal of PTP output 3.					

Signal	Symbol	Function	Applicable mode		
PTP output 4	PTPO4	0x1A	P		
It is the signal of PTP output 4.					

Signal	Symbol	Function	Applicable mode		
PTP output 5	PTPO5	0x1B	P		
It is the signal of PTP output 5.					

Signal	Symbol	Function	Applicable mode		
PTP output 6	PTPO6	0x1C	P		
It is the signal of PTP output 6.					

Signal	Symbol	Function	Applicable mode		
PTP output 7	PTPO7	0x1D	P		
It is the signal of PTP output 7.					

Signal	Symbol	Function	Applicable mode		
Gantry synchronization cancellation output	GSC	0x1E	P		
It is the output signal of gantry synchronization cancellation.					

Signal	Symbol	Function	Applicable mode		
Dynamic brake relay control	DBRC	0x1F	P	S	T
It is the output signal of dynamic brake relay control.					

4.4.5 Pulse input signals and functions

Sign	Pin	Signal	Function
OCP	38	Position command pulse input 1	<ul style="list-style-type: none"> ● In position control mode, the terminals function as position command input terminals. ● In other control modes, the terminals are invalid. ● The maximum input pulse frequency is 4 MHz in differential mode and 200 kHz in open collector mode.
PULS+	23		
PULS-	24		
OCS	31	Position command pulse input 2	
SIGN+	32		
SIGN-	33		

4.4.6 Analog input signals and functions

Sign	Pin	Signal	Default	Input	Function
AD1	20	Analog input 1	0x03	Speed command	<ul style="list-style-type: none"> ● AD1 and AD2 are accurate to 12 bits. ● For external analog input terminals, the input impedance is 13kΩ, and the input voltage ranges from -10V to +10V. If the voltage is out of the range of -11V~+11V, the drive may be damaged. ● The range, offset, and function definition are configurable.
AD2	7	Analog input 2	0x04	Torque command	
GND	6	Signal ground	-	-	

4.4.7 Encoder output signals and functions

Sign	Pin	Signal	Function
OA+	44	Phase-A output	<ul style="list-style-type: none"> ● The output of encoder signal that is frequency divided is compliant with TIA/EIA-422-B. ● The output phase-A pulse and phase-B pulse are still orthogonal. In forward rotation, phase A leads phase B by 90°. In reverse rotation, phase B leads phase A by 90°. ● The frequency can be divided or multiplied by any integer or fraction.
OA-	43		
OB+	41	Phase-B output	
OB-	42		
OZ+	28	Phase-Z output	
OZ-	27		

4.5 Wiring description for CN1

4.5.1 Digital input circuit wiring

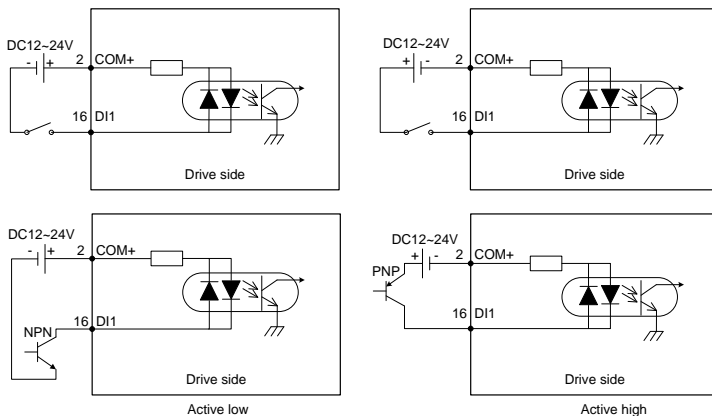

- The digital input power is user provided.
- As shown in the figure, the digital input circuit supports mechanical switch connection and open collector connection using NPN or PNP triodes, disallowing the hybrid of the two types.

4.5.2 Pulse input circuit wiring

Method 1: Differential connection

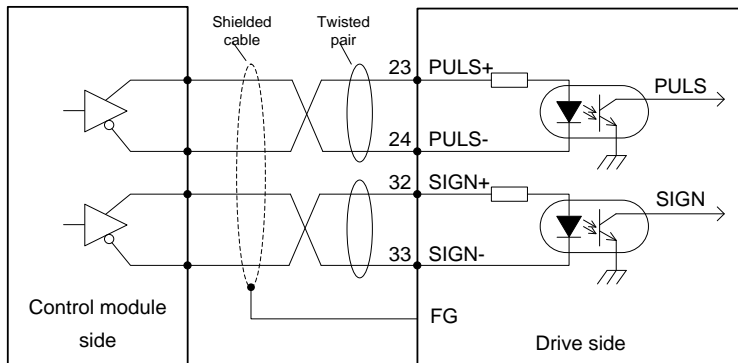

- The differential pulse input signal voltage is $\pm 5V$ and maximum frequency is 4 MHz.
- This signal transmission method is recommended since it has excellent anti-noise capability.

Method 2: Open collector connection 1

Control module using NPN triodes with common cathode:

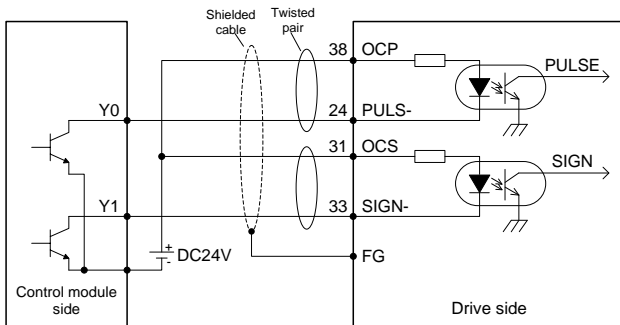

Control module using PNP triodes with common anode:

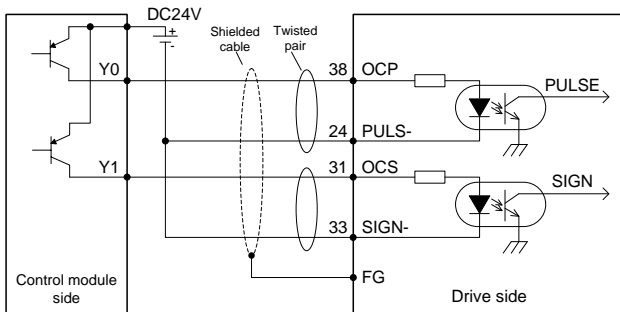

The maximum input pulse frequency is 200 kHz. If the 24V power is provided by yourself, no current limit resistor is needed. Generally, the PLC from a Japanese manufacturer uses the NPN type, while that from a European manufacturer uses the PNP type.

Method 3: Open collector connection 2

Control module using NPN triodes with common cathode:

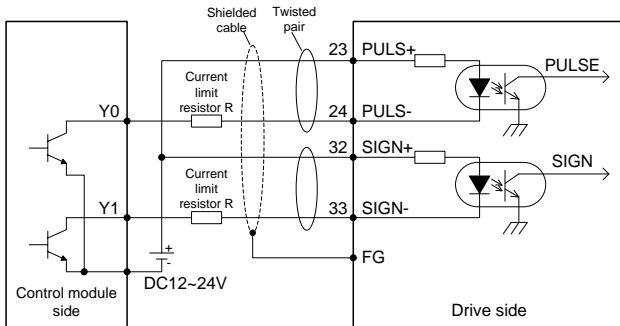

Control module using PNP triodes with common anode:

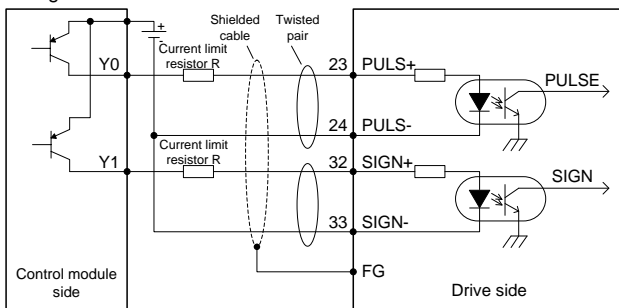

The maximum input pulse frequency is 200 kHz. Use the 12–24V power provided by yourself. You need to connect current limit resistors externally. Select current limit resistors according to the following:

V_{DC}	R specs
12V	1k Ω , 1/4W
24V	2k Ω , 1/3W

$$\frac{V_{DC}-1.5}{R+68} \approx 10(\text{mA})$$

For each method, the shielded twisted pair is required, and you are recommended that the pair cable length be less than 3 meters.

4.5.3 Analog input circuit wiring

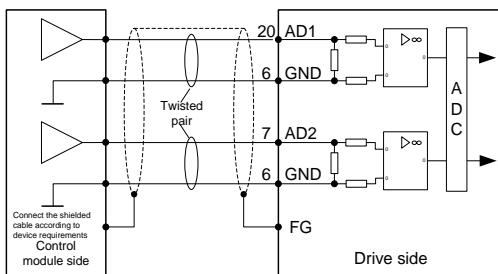

There are two channels of analog input circuit, AD1 and AD2, both of which are accurate to 12 bits. The input impedance is 13k Ω . The input voltage ranges from -10V to +10V. If the voltage is $\pm 11V$ less or greater, the circuit may be damaged.

4.5.4 Digital output circuit wiring

Wiring method in which user-provided power is used

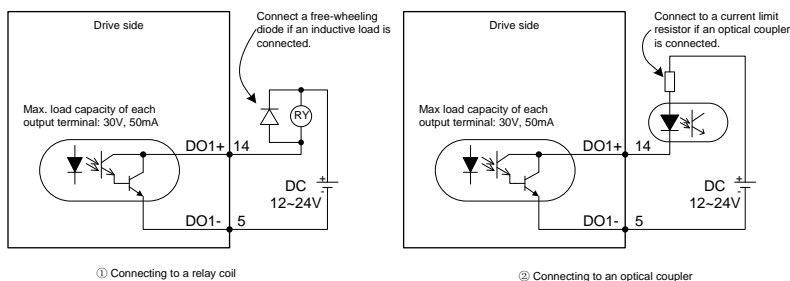

- There are six digital output circuits in total, which use the open-collector output structure as shown in the figure. They can be used to drive the relay coil or optical coupler load. The loading capacity is shown in the figure.
- If an inductive load such as the relay coil is connected, a free-wheeling diode must be connected, as shown in the figure. If an optical coupler is connected, a current limit resistor must be connected; otherwise, the drive may be damaged.

4.5.5 Frequency-division output circuit wiring of encoder feedback signals

Differential method

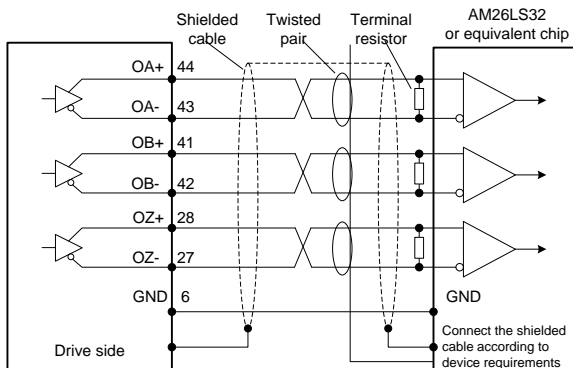

- Phases A, B, and Z of the encoder provide differential output signals. You are recommended to use AM26C32 or equivalent chip and connect an end-matching resistor of about 220Ω.
- No isolation is made for any output circuit.

4.5.6 Electromagnetic brake wiring

If the servo motor is used to drive the vertical shaft, the electromagnetic brake can be used to prevent against the falling of heavy objects or keep the falling speed when the servo drive is out of power. See the following wiring diagram for the electromagnetic brake.

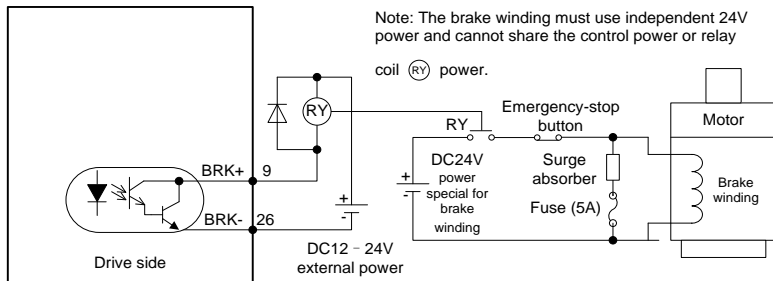

- You must provide independent 24V power for the electromagnetic brake, which cannot use the signal-control power.
- In the figure, (RY) indicates relay coil. Pay attention to the diode direction.
- The electromagnetic brake is used for holding but not for common stop.
- Though the electromagnetic brake can prevent the falling of heavy objects or keep the falling speed, you must install an external brake device.

5**Operating and running**

5.1 Running.....	57
5.1.1 First power-on.....	57
5.1.2 Trial run by jogging	58
5.1.3 Running in position control mode	59
5.1.4 Running in speed control mode.....	60
5.1.5 Running in the torque control mode.....	61
5.1.6 Setting parameters before servo running	62
5.1.7 Servo enabling	62
5.1.8 Servo stop and running stop.....	63
5.1.9 Timing sequence	64
5.2 Display and operating	67
5.2.1 Display.....	67
5.2.2 Common monitoring mode	69
5.2.3 Monitoring mode.....	70
5.2.4 Parameter setting mode	70
5.2.5 Auxiliary function mode.....	71
5.2.6 Alarm reporting	74
5.2.7 Alarm clearing.....	74

5.1 Running

5.1.1 First power-on

Ensure the following before the power-on:

Wiring

- The power supply (L1 and L2) of the servo drive is connected correctly. For details, see section 3.2 "Main circuit terminal wiring".
- The servo drive output phases (U, V, and W) are consistent with servo motor cable phases.
- There is no short circuit between the servo drive outputs (U, V, and W) and the input power (L1 and L2).
- Wiring complies with the standard wiring diagrams for different control modes in chapter 4 "Control modes".
- The external servo enabling terminal SON is set to OFF.
- The servo drive and the servo motor are grounded properly.
- If an external brake resistor is used, for products with small power range, the short-connection cable between B2 and B3 must be removed.
- The voltage applied to CN1 cannot be greater than DC24V.
- Stresses applied to cables are within the allowed ranges.

Environment

There are no foreign materials, such as wire leads and metal filings, which can cause short connection between signal and power cables.

Mechanical parts

- The installation of the servo motor and the connection between shafts and machines are reliable.
- The servo motor and connected machines are operational.
- Do not run the motor with a negative load, which indicates the motor output torque direction is opposite to the motor speed direction.

You can turn on the power only after all the preceding conditions are met.

5.1.1.1 Sequence of power-on and power-off

The control circuit and main circuit of the drive are powered together, thus indicating L1 and L2 are powered together.

5.1.1.2 Checking after power-on

After the power is switched on, if the powering is normal, each position on the LED panel displays 0 and then 8.

If the servo drive does not report a fault alarm, the default monitoring menu (motor speed by default) is displayed, and the servo drive and servo motor do not sound abnormally. The parameter P0.15 indicates the default display for power-on.

If the servo drive reports a fault alarm, the LED panel displays the symbol of the current alarm and blinks. See chapter 9 "Fault handling" to handle the fault.

5.1.1.3 Setting the motor code

Before enabling the motor, set the parameter P0.00 according to the motor code on the motor nameplate. Otherwise, the motor cannot run properly or it runs in the reverse direction, which may cause safety risks.

5.1.2 Trial run by jogging

Trial jogging can be used to check whether the servo drive and the servo motor are in good condition and to commission the system including the servo drive, servo motor, and peripherals. If the system is wired and powered on properly, without reporting a fault alarm, execute jogging operations to perform trial run for the servo motor. See section 5.2.5.2 "Jogging test" for detailed instructions. Before jogging running, ensure that:

- The motor is not in running state. Jogging operations are invalid for a motor in running state.
- It is recommended that the load inertia not be greater than 15 times of the motor inertia. Otherwise, serious mechanical vibration may be caused.
- The jogging speed has been set through P0.05.
- The ACC time and DEC time can be set through P0.54, P0.55, P0.56, and P0.57.

5.1.3 Running in position control mode

Simplified wiring

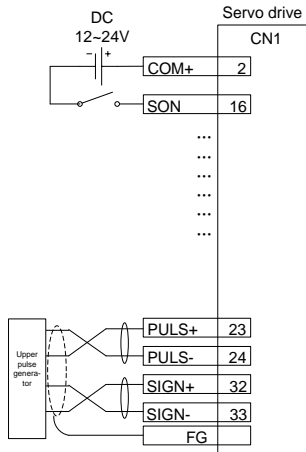

Parameter	Function	Setting
P0.03 ¹	Control mode	0
P0.22 ¹	Pulses per motor resolution	Depends on the actual situation.
P0.23 ¹	Pulse input mode	Depends on the actual situation.
P0.24 ¹	Reverse pulse input direction	0

Procedure

1. Complete the connect between the servo drive and servo motor.
2. Set P0.03 to 0, which indicates the position control mode.
3. Check the pulse output mode of the upper controller. Adjust P0.23 to keep the pulse mode the same as that of the upper controller. See the description for P0.23 for details.
4. Switch off and re-switch on the main power for the settings of P0.03 and P0.23 to take effect.
5. Connect the plug of CN1 to the drive, switch on the power, and ensure that SON and 24V GND are connected. The motor enters the locking state.
6. Wait the upper controller to send the low frequency pulse command. The motor rotates at a low speed.
7. Check whether the motor rotation direction is consistent with the design. If not, change the direction through the upper controller or perform the reverse operation through P0.24.
8. Ensure the input pulse count complies with the design. You can set P0.22 [Pulses per motor resolution] or the electronic gear ratio parameters P0.25 and P0.26 to divide or multiply frequency. See the description for P0.22, P0.25 and P0.26 for details.

5.1.4 Running in speed control mode

Simplified wiring

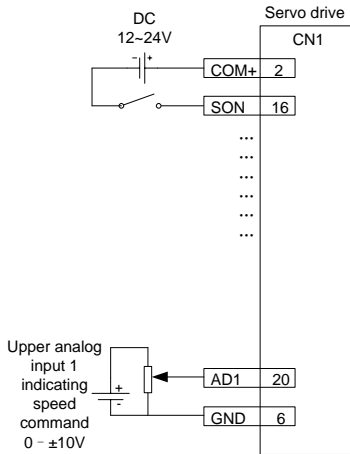

Parameter	Function	Setting
P0.03 ¹	Control mode	1
P0.40	Speed command source	1
P3.26	Function of AI 1	3
P0.42	Gain of AI 1	500
P3.20	Offset of AI 1	Depends on the actual situation.

Procedure

1. Complete the connect between the servo drive and servo motor.
2. Set P0.03 to 1, which indicates the speed control mode.
3. Switch off and re-switch on the main power for the setting of P0.03 to take effect.
4. Set P0.40 to 1, which indicates that the speed command source is external analog.
5. Set P3.26 to 3, which indicates that analog input 1 is a speed command.
6. Set P0.42 as required. See the description for P0.42 for details.
7. Connect the plug terminals for CN1.
8. Connect the plug of CN1 to the drive, switch on the power, and ensure that SON and 24V GND are connected. The servo enters the locking state.
9. The motor shaft may rotate at a low speed if there is no upper command voltage. It is necessary to adjust P3.20. See the description for P3.20 for details.

5.1.5 Running in the torque control mode

Simplified wiring

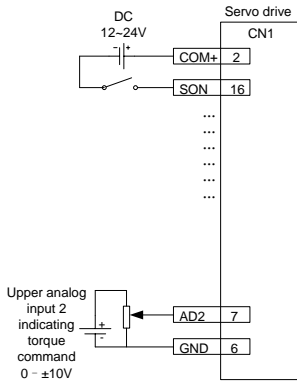

Parameter	Function	Setting
P0.03 ¹	Control mode	2
P0.60	Torque command source	1
P3.27	Function of AI 2	4
P0.61	Torque command direction setting	Depends on the actual situation.
P0.62	Gain of AI 2	10
P3.23	Offset of AI 2	Depends on the actual situation.
P0.46	Speed limit 1	100

Procedure

1. Complete the connect between the servo drive and servo motor.
2. Set P0.03 to 2, which indicates the torque control mode.
3. Switch off and re-switch on the main power for the setting of P0.03 to take effect.
4. Set P0.60 to 1, which indicates the torque command source is external analog.
5. Set P0.61 as required. See the description for P0.61 for details.
6. Set P3.27 to 4, which indicates that analog input 2 is a torque command.
7. Set P0.62 as required. See the description for P0.62 for details.
8. Connect the plug terminals for CN1.
9. Connect the plug of CN1 to the drive, switch on the power, and ensure that SON and 2V GND are connected. The servo enters the locking state.
10. The motor shaft may rotate at a low speed if there is no upper command voltage. It is necessary to adjust P3.23. See the description for P3.23 for details.
11. In torque control mode, adjust P0.46, which indicates the speed limit. See the description for P0.46 for details.

5.1.6 Setting parameters before servo running

To meet onsite application function and performance requirements, you must set parameters by using the LED panel, PC software, or communication means before servo running. Chapter 6 describes all parameters, among which some must be set depending on the actual application requirements, such as the pulse input manner, electronic gear ratio, encoder output frequency division coefficient, and analog input upper or lower limit, while some must be set depending on the actual commissioning status, such as the regulator loop parameter affecting system performance, but most parameters use the default settings.

The following lists only part of mandatory parameters:

Control mode

The control modes include the position, speed, and torque control modes, and any combination of the three modes. Depending on actual control requirements, set the control mode through P0.03. You must switch off and re-switch on the main power for the setting of P0.03 to take effect.

Command input

Based on the setting of P0.03, set or enter commands to control the position, speed, or torque of the servo motor shaft.

- In position control mode, the applicable command can be the pulse command (with three input methods), internal torque limit command, or external analog torque limit command.
- In speed control mode, the applicable command can be the internal speed command, external analog speed command, internal torque limit command, or external analog torque limit command.
- In torque mode, the applicable command can be the internal torque command, external analog torque command, internal speed limit command, or external analog speed limit command.

5.1.7 Servo enabling

You can enable the servo through the external servo enabling terminal SON or P0.04.

When the servo is enabled:

- If no alarm is reported, the servo panel displays the default monitoring parameters.
- The fan starts running.
- In position control mode, if there is no pulse command input, the servo enters the locked state.
- In speed control mode, the servo motor runs at the given speed.
- In torque control mode, if no torque is applied externally, the servo motor accelerates from the zero speed to the limited speed. If the external torque is greater than the torque in the internal torque command, the servo motor remains the state of zero speed output.
- If a servo alarm is reported, the servo panel displays ErXX-X and blinks. The servo motor enters the inertia running state.

5.1.8 Servo stop and running stop

The drive cuts off output immediately, and the motor coasts to stop until it decelerates to the zero speed, but it does not keep in locked state, which is servo stop. The drive outputs reverse torque, and the motor decelerates to the zero speed and enters the locked state, which is running stop. The servo motor stops or it stops running if the servo drive is in any of the following conditions:

- ◆ The servo enabling terminal SON is set to OFF. This does not cause regenerative brake.
You can select a stop manner through P4.30.
- ◆ A fault alarm is reported. This does not cause regenerative brake.
You can select a servo motor stop manner through P4.30.
- ◆ When the digital input terminal configured as zero speed clamp (ZRS) is set to ON and P0.58 is set to a non-zero value, the servo motor stops running. When P0.58 is set to 1–3, the motor stops running based on the DEC time set by P0.55 and P0.57 in speed mode, and servo is in locked state after stop; in torque mode, the servo motor stops running immediately. Such stopping process may cause regenerative braking. If a braking overload fault alarm occurred, connect a proper external brake resistor.
- ◆ If the travel limit switch function is invalid (that is, P3.40=0), and the digital input terminal signal of travel limit (POT/NOT) is set to ON, the motor decelerates to stop running based on the settings of P0.55 and P0.57 and it enters locked state. If there is reverse direction command input after the motor stops, the motor can run in reverse direction.
- ◆ If the emergency stop disabling function is invalid (that is, parameter P3.41=0), and the digital input terminal of EMG is set to ON, the servo motor coasts to stop.
- ◆ If the servo disabling signal duration is too short (that is, less than 500ms), the PWM signal may be in off state after the servo is enabled again.

5.1.9 Timing sequence

5.1.9.1 Timing sequence for power-on and servo turning on

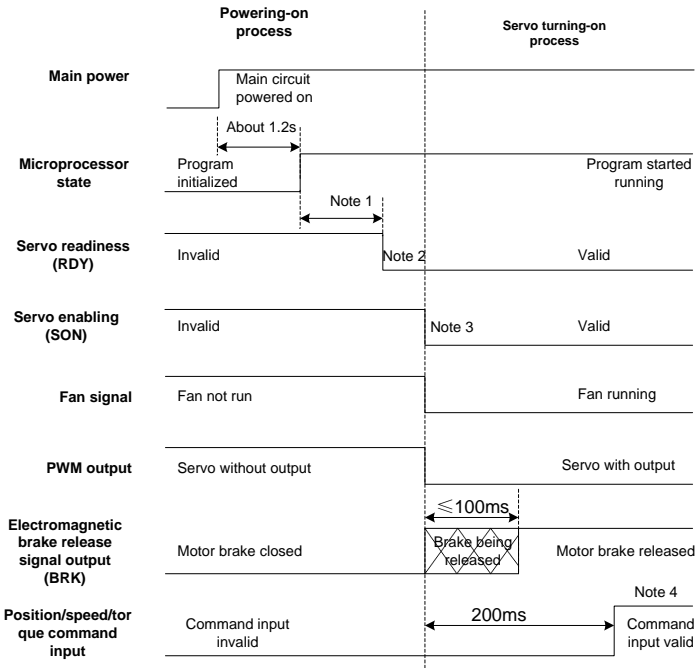

Note 1: The delay time from microprocessor initialization completion to servo readiness output can be set through P4.54.

Note 2: The condition for the RDY output signal electric level to become low is: The servo has no fault and main circuit DC voltage has been established, with voltage higher than 250V/430V (for 220V/400V series). If the main circuit DC voltage is less than 170V/310V (for 220V/400V series), the Er13-1 alarm is reported. The time interval from servo readiness to servo enabling can be user controlled.

Note 3: The servo enabling signal can be valid only when the RDY output signal is valid.

Note 4: The actual electric levels corresponding to valid I/O states can be set through P3.00–P3.15.

5.1.9.2 Timing sequence for power-off during running

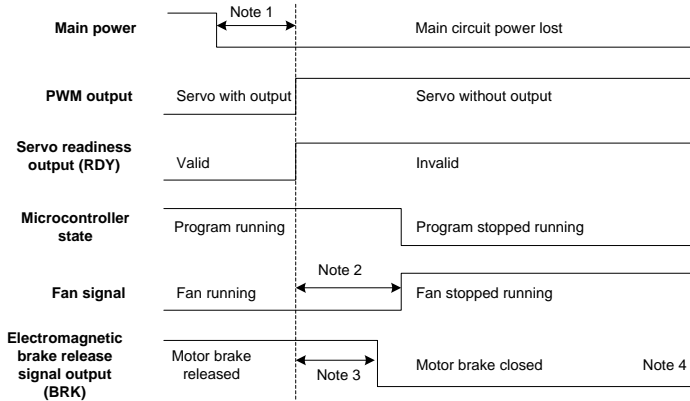

Note 1: If main circuit voltage is less than 170V/330V(for 220V/400V series), the undervoltage fault occurs and the electrical level of the servo fault (ALM) output increases.
 Note 2: If the drive temperature is less than 45 °C, the fan stops. If the IGBT temperature is higher than 45 °C, the fan stops after the microprocessor stops.
 Note 3: The output delay of the electromagnetic brake release signal can be set through P3.57. If the speed slows down under the setting of P3.58 (30r/min by default) during the time specified by P3.57, the BRK signal becomes invalid.
 Note 4: The actual electrical levels corresponding to valid I/O states can be set through P3.00–P3.15.

5.1.9.3 Timing sequence for servo turning off in locked state

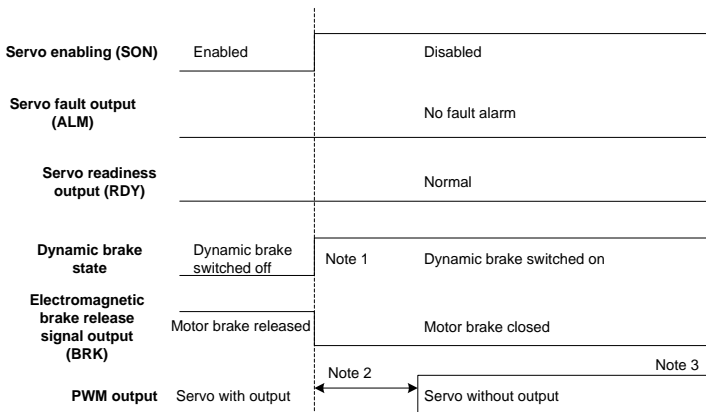

Note 1: Whether to immediately start the dynamic brake can be set through P4.30.
 Note 2: The servo locking time after braking can be set through P3.56.
 Note 3: The actual electrical levels corresponding to valid I/O states can be set through P3.00–P3.15.

5.1.9.4 Timing sequence for servo turning off in running state

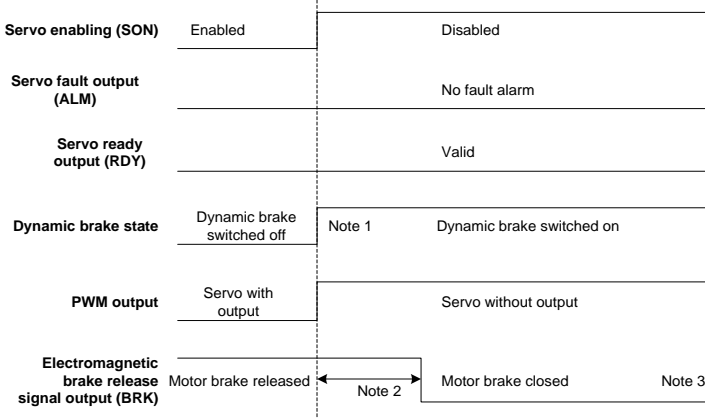

Note 1: Whether to immediately enable the dynamic brake can be set through P4.30.
 Note 2: The output delay of the electromagnetic brake release signal is specified by P3.57. If the speed slows down under the setting of P3.58 during the time specified by P3.57, the BRK signal becomes invalid.
 Note 3: The actual electrical levels corresponding to valid I/O states can be set through P3.00–P3.15.

5.1.9.5 Timing sequence for fault alarm reporting

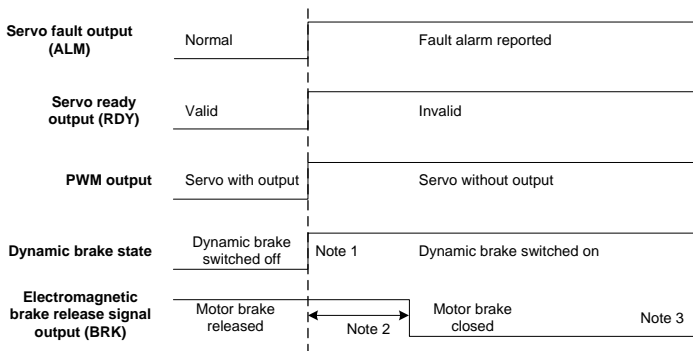

Note 1: Whether to immediately enable the dynamic brake can be set through P4.30.
 Note 2: The output delay of the electromagnetic brake release signal is specified by P3.57. If the speed slows down under the setting (30r/min by default) of P3.58 during the time specified by P3.57, the BRK signal becomes invalid.
 Note 3: The actual electrical levels corresponding to valid I/O states can be set through P3.00–P3.15.

5.2 Display and operating

5.2.1 Display

- Keypad diagram

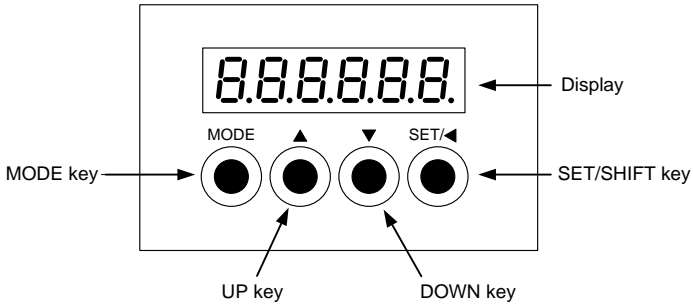

- LED characters and meanings

Character	Meaning	Character	Meaning	Character	Meaning	Character	Meaning
0	0	1	1	2	2	3	3
4	4	5	5	6	6	7	7
8	8	9	9	.	.	-	-
a	a	b	b	c	c	d	d
e	e	f	f	g	g	h	h
i	i	j	j	k	k	l	l
m	m	n	n	o	o	p	p
q	q	r	r	s	s	t	t
u	u	v	v	w	w	x	x
y	y	z	z				

● **Key functions**

Key	Function
MODE	Used to switch between different modes or return to the previous menu.
UP	Used to select parameter upwards or increase values. For a parameter displayed in multiple segments, it can be used to shift to the most significant bit (MSB), middle, and least significant bit (LSB) segments.
DOWN	Used to select parameter downwards or decrease values. For a parameter displayed in multiple segments, it can be used to switch between the MSB, middle bit, and LSB segments.
SET/SHIFT	Hold this key (about 0.6s) = SET Used to enter a sub-level menu in parameter mode or to set parameters in editing mode. Press this key = SHIFT Used to change a group code in parameter mode or to enter a position where the digit needs to change in editing mode.

● **Operation flowchart**

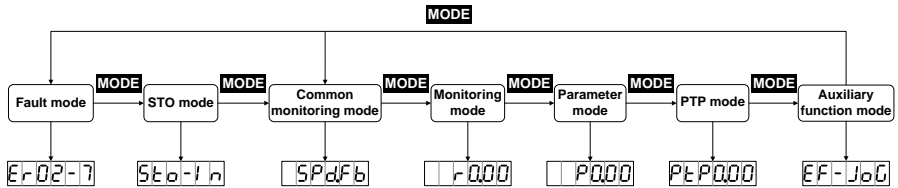

After the drive is powered on, the panel displays **000000** about 1 second and then **888888** about 1 second. After that, the common monitoring mode is entered.

1. Press **MODE** to circularly switch between different modes in the sequence of "Common monitoring mode" → "Monitoring mode" → "Parameter mode" → "PTP mode" → "Auxiliary function mode" → "Fault mode" → "STO mode". If there is no fault or no STO input, the fault mode and STO mode can be skipped.
2. If a new fault occurs, the fault mode is entered automatically, but you can press **MODE** to switch to another mode. If no key is pressed in 20 seconds, the fault mode is switched back automatically.
3. In common monitoring mode, **UP/DOWN** can be used to switch between monitoring parameters. Parameter names are displayed for 2.5 seconds, and then the values are displayed.

4. In parameter mode, **SHIFT** can be used to switch between group codes, and **UP/DOWN** can be used to select codes for parameters in a group.
5. In parameter setting mode, press **SHIFT** to move the cursor left and then press **UP/DOWN** to change the setting for the MSB.
6. After parameters are set, press **SET** to save the parameter settings or execute commands.
7. After parameters are set, the LED panel displays **SAVE** (if the parameters are storage parameters and P0.17 is set to 0 [Individually]) or **SUCCESS** (if the parameters are non-storage parameters or P0.17 is set to 1 [In batches]). Then the parameter mode is switched back automatically.
8. Set long parameters (with 6 digits at least).

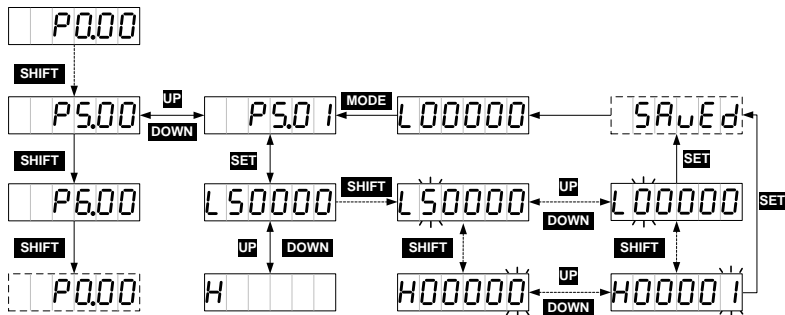

5.2.2 Common monitoring mode

After the drive is powered on, the LED panel enters the common monitoring mode by default. It displays the names of monitoring parameters for 2.5 seconds, and then the values. You can press **MODE** to return to the parameter name display screen. Then you can press **UP/DOWN** to switch between monitoring parameters. For details, see section 10.3 "Common monitoring parameters". The monitoring parameters that are displayed by default can be set by P0.15. If no operation is performed on the non parameter value display screen in 20 seconds, the common monitoring parameter screen is displayed.

Operation flowchart

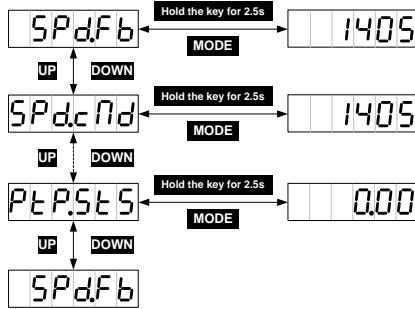

5.2.3 Monitoring mode

You can press **MODE** to switch to the monitoring mode. Then you can press **SHIFT** to select group codes for monitoring parameters circularly in one way, press **UP/DOWN** to select codes for parameters in a group, or hold **UP/DOWN** for quick selection. After locating a target parameter, you can press **SET** to check the current value and then press **MODE** to switch to the parameter code display screen. If no operation is performed on an R3 menu screen in 20 seconds, the common monitoring parameter screen is displayed. If no operation is performed on an R0 or R1 menu screen in 20 seconds, the current parameter display screen is kept.

Operation flowchart

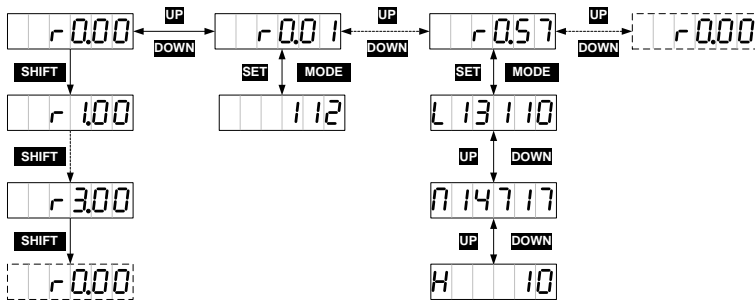

5.2.4 Parameter setting mode

You can press **MODE** to switch to the parameter setting mode. You can press **SHIFT** to select group codes for parameters circularly in one way, press **UP/DOWN** to select codes for parameters in a group, or hold **UP/DOWN** for quick selection. After locating a target parameter, you can press **SET** to enter the current parameter value display screen and then press **SHIFT** to enter the parameter setting screen where the parameter LSB blinks). After parameter setting, the LED displays **SPd.Fb** (if the

parameters are storable and P0.17 is set to 0) or **SUccES** (if the parameters are non-storage parameters or P0.17 is set to 1). The parameter mode is switched back automatically.

Operation flowchart

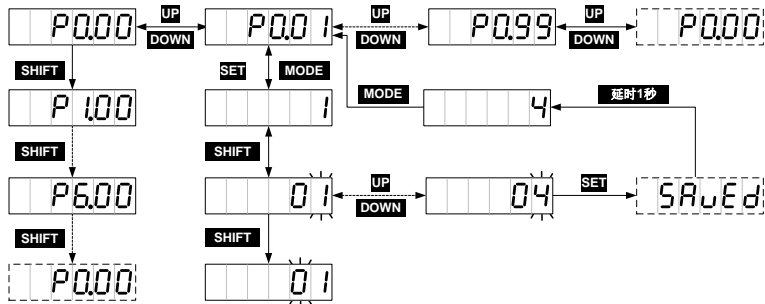

5.2.5 Auxiliary function mode

5.2.5.1 Functions

You can press **MODE** to enter the auxiliary function mode and press **UP/DOWN** to select auxiliary functions.

Symbol	Function
EF-JoG	Program Jog
EF-dRF	Factory restore
EF-PJo	Program jogging
EF-AR1	Zero-drift clearing for analog input 1
EF-AR2	Zero-drift clearing for analog input 2
EF-AR3	Zero-drift clearing for analog input 3
EF-JId	Inertia identifying
EF-Enc	Absolute encoder clearing

Note: All auxiliary functions can be executed only when the servo is disabled. The auxiliary function menu is inaccessible when the servo is enabled.

5.2.5.2 Jogging test

You can press **MODE** to switch to the auxiliary function mode. You can press **UP/DOWN** to enter the **EF-JoG** menu and press **SET** to enter the jogging test screen, displaying the current rotation speed of the motor. If you press and hold **UP**, the motor rotates at the specified speed

counterclockwise. It stops if you releases the key. If you press and hold **DOWN**, the motor rotates at the specified speed clockwise. It stops if you releases the key.

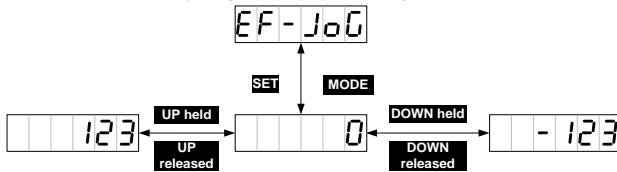

5.2.5.3 Factory parameter restoring

You can press **MODE** to switch to the auxiliary function mode. You can press **UP/DOWN** to enter the **EF-dRF** menu and press **SET** to enter the default parameter restoring screen, displaying **rEAdY**. Then you can press **SET** to restore parameters. During the restoring process, the screen displays **StARt**. When the process ends, the screen displays **FinIsh**. The zero-drift clearing process for analog input 1, 2, and 3 is similar to the factory parameter restoring process.

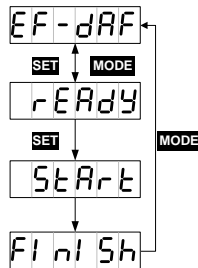

5.2.5.4 Program jogging

After the run parameters P5.00–P5.05 are set, you can press **MODE** to switch to the auxiliary function mode. Then you can press **UP/DOWN** to enter the **EF-PJOG** menu and press **SET** to enter the program jogging screen, displaying **rEAdY**. Then you can press **SHIFT** to switch between **rEAdY** and **0000** to enable and disable program jogging. On the **0000** screen, you can press **UP** or **DOWN** to start program jogging. The use of the **UP** or **DOWN** key is associated with P5.00. If the motor running direction is counterclockwise, the **UP** key must be used for the starting. If the motor running direction is clockwise, the **Down** key must be used for the starting. After the starting, the current rotation speed of the motor is displayed.

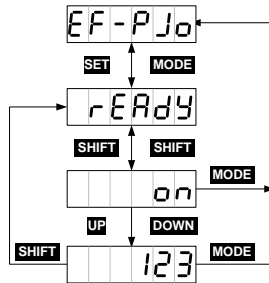

5.2.5.5 Inertia identifying

You can press **MODE** to switch to the auxiliary function mode. You can press **UP/DOWN** to enter the **EF-JI d** menu and press **SET** to enter the inertia identifying menu, which displays **rERdy**. Then you can press **SET** to enable inertia identifying. After inertia identifying is complete, the result data such as **23** is displayed about three seconds and then saved automatically. The screen returns to the parameter setting menu automatically after displaying **SAvEd** about two seconds.

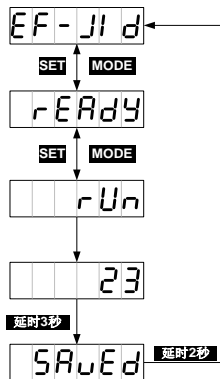

5.2.5.6 Absolute encoder clearing

If a multiturn absolute encoder is used, the homing operation for the mechanical system must be performed after the first power-on. Then you can press **MODE** to enter the auxiliary function mode, press **UP/DOWN** to enter the **EF-Enc** menu, and press **SET** to enter the absolute encoder clearing menu, which displays **rERdy**. Then you can press **SET** to enable absolute encoder clearing. The screen displays **StARt**. If the clearing is successful, the screen displays **FinI Sh**. If the encoder type does not match or the clearing fails, the screen displays **Error**.

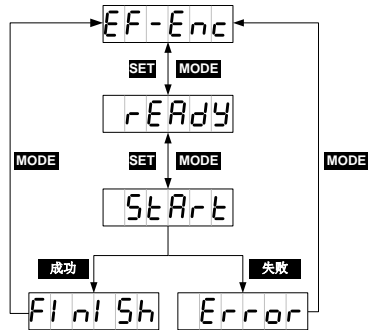

5.2.6 Alarm reporting

If the servo drive runs abnormally, it reports a fault alarm and stops automatically, while the LED panel displays the fault alarm symbol in the format of ErXX-X, in which XX is the main code and X is the sub code.

For details, see section 10.4 "Fault codes".

5.2.7 Alarm clearing

For the fault alarms that can be cleared online, if there are no fault trigger conditions, the fault alarms can be cleared by short connecting the digital input fault clearing terminal (that is, parameters P3.00–P3.07 are set to 0x004 or 0x104) to COM-. If the servo still has enabling command input, the drive cannot clear the faults automatically.

You can power off and repower on the drive to clear the fault alarms that cannot be cleared online.

6**Function codes**

6.1 Basic control (group P0).....	76
6.1.1 Basic settings	76
6.1.2 Position control	86
6.1.3 Speed and torque control	91
6.1.4 Control mode switching	102
6.1.5 Speed display filtering	104
6.2 Autotuning control (group P1)	104
6.2.1 Inertia identifying (or automatic gain).....	104
6.2.2 Self-adaptive vibration control	107
6.3 Motor control (group P2)	112
6.3.1 Gain settings	112
6.3.2 Gain switching	115
6.3.3 Special motor control.....	121
6.4 I/O management (group P3)	127
6.4.1 Digital input/output.....	127
6.4.2 Analog input/output.....	133
6.4.3 Digital input/output associated settings	139
6.5 Extension and application (group P4)	144
6.5.1 Communication.....	144
6.5.2 Servo types and communication control commands	147
6.5.3 Extension and application.....	151
6.5.4 Frequency-division output and second-encoder settings.....	157
6.5.5 Special commands	161
6.6 Program Jog, homing, and PTP control (group P5)	163
6.6.1 Program Jog settings.....	163
6.6.2 Homing	165
6.6.3 PTP control.....	169
6.7 Application functions (group P6)	178
6.8 PTP control (groups PtP0, PtP1, and PtP2).....	183
6.9 Status monitoring	220
6.9.1 System monitoring (group R0).....	220
6.9.2 I/O monitoring (group R1).....	231
6.9.3 Fault recording (group R3)	234

Note:

- In the **Applicable mode** column, P indicates position control mode, S indicates speed control mode, and T indicates torque control mode.
- For directions, from the view of facing the motor shaft, the forward direction is counterclockwise (CCW for short), and the reverse direction is clockwise (CW for short); in terms of speed and torque settings, a positive value corresponds to the forward direction and a negative value corresponds to the reverse direction.
- For function codes:
 - Marked with the superscript "1", the parameter settings take effect only after the drive is restarted or repowered on.
 - Marked with the superscript "2", the parameter settings take effect only when the servo stops. The modification during running does not take effect.
 - Marked with the superscript "**", the parameter settings are not stored after the drive is powered off.
- For communication addresses
 - They are in decimal format when Modbus is used.
 - They are in hexadecimal format when CANopen is used. The code with 16 bits is the main code and the code with 8 bits is the sub code.

6.1 Basic control (group P0)

6.1.1 Basic settings

P0.00 ¹	Motor model	Setting range	Default	Unit	Applicable mode		
		0–9999999	1010104*1	-	P	S	T

This parameter is set to 0 by default. Change the setting according to the specifications on the motor nameplate.

If the motor model is 0 and it is connected to a standard communication-type encoder, the drive automatically reads motor parameters.

For example, the nameplate of a 400W motor is as follows:

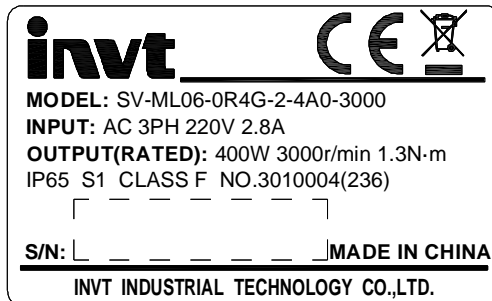

In the figure, 3010004 in "No.3010004" is the value of this parameter.

Note: Incorrect setting of this parameter may cause abnormal running or even serious drive or motor fault. Ensure that the parameter setting matches the motor before the first power-on.

P0.00 ¹	Data size	32bit	Data format	DEC
	Modbus address	1000, 1001	CANopen address	0x2000, 0x00

P0.01 ¹	Encoder type	Setting range	Default	Unit	Applicable mode		
		1–12	4 ^{*1}	-	P	S	T

In most cases, if P0.00 is set correctly, the system assigns a value to this parameter. You do not need to set it. If an encoder disconnection fault is reported during power-on though the motor is connected correctly, check whether the drive supports the encoder used by the motor. For details, see section 1.1.3 "Drive naming". The servo motor code contains the encoder type. For details, see section 1.2.2 "Motor naming".

The mapping between encoder types and settings of P0.01 is as follows:

Motor nameplate encoder type ^{*2}	Setting	Meaning
3	3	17-bit single-turn absolute encoder
4	[4]	17-bit multiturn absolute encoder ^{*3}
9	10	23-bit multiturn absolute encoder ^{*3}
-	Other	Reserved

^{*1} The encoder type varies with the motor type.

^{*2} See No. 8 in the table in section 1.2.2 "Motor naming" for encoder types.

^{*3} If you use a multiturn encoder, change the battery only when the drive power is on, which prevents the absolute position from being lost. The standard battery is 2000 mAh and the replacement cycle is 1.5–2 years.

P0.01 ¹	Data size	16bit	Data format	DEC
	Modbus address	1002, 1003	CANopen address	0x2001, 0x00

P0.02 ¹	Forward direction of motor rotating ^{*1}	Setting range	Default	Unit	Applicable mode		
		0–1	0	-	P	S	T

This parameter specifies the forward direction of motor rotating.

Setting	Meaning
[0]	The forward direction is counterclockwise.
1	The reverse direction is clockwise.

^{*1} The direction definition assumes that you face the output shaft of the motor.

P0.02 ¹	Data size	16bit	Data format	DEC
	Modbus address	1004, 1005	CANopen address	0x2002, 0x00

P0.03 ¹	Control mode	Setting range	Default	Unit	Applicable mode		
		0-9	0	-	P	S	T

This parameter specifies the system working mode.

Setting	Primary mode	Secondary mode	Description
[0]	P	/	Position mode: The angular displacement of the servo motor is controlled through internal or external position commands, thus achieving the control over mechanical motion displacement.
1	S	/	Speed mode: The rotation speed of the servo motor is controlled through internal or external speed commands.
2	T	/	Torque mode: The torque of the servo motor is controlled through internal or external torque commands.
3	P	S	<p>Switching between the position and speed modes: The position mode and speed mode can be switched through the control mode switching terminal.</p> <p>Note: There are two methods (specified by P0.92) to switch from the position mode to the speed mode. In the process of switching from the speed mode to the position mode, the motor stops at the reference position specified by P0.91 before switching to the position mode.</p>
4	P	T	<p>Switching between the position and torque modes: The position mode and torque mode can be switched through the control mode switching terminal.</p> <p>Note: There are two methods (specified by P0.92) to switch from the position mode to the torque mode. In the process of switching from the torque mode to the position mode, the motor stops at the reference position specified</p>

			by P0.91 before switching to the position mode.
5	S	T	<p>Switching between the speed and torque modes: The speed mode and torque mode can be switched through the control mode switching terminal.</p> <p>Note: The switching is not limited by the current working condition.</p>
6	/	/	Reserved
7	CANopen	/	CANopen mode (supported by the CANopen servo)
8	EtherCAT	/	EtherCAT mode (supported by the EtherCAT servo)

Remarks: If P0.03 is set, parameters P3.00–P3.07 are automatically switched according to the current control mode. The input settings of P3.00–P3.07 are described as follows:

0: Off (The internal optical coupler corresponding to the input is not conducted.)

1: On (The internal optical coupler corresponding to the input is conducted.)

P0.03 ¹	Data size	16bit	Data format	DEC
	Modbus address	1006, 1007	CANopen address	0x2003, 0x00

P0.04*	Internal enabling command	Setting range	Default	Unit	Applicable mode		
		0–1	0	-	P	S	T

This parameter is used to control the working status of the servo drive.

The mapping between the settings of this parameter and external terminal enabling commands are as follows:

Setting	External terminal command	Servo drive is
0	0 (The internal optical coupler corresponding to the input is not conducted.)	Stand-by (OFF)
0	1 (The internal optical coupler corresponding to the input is conducted.)	Enabled (ON)
1	0 (The internal optical coupler corresponding to the input is not conducted.)	Enabled (ON)
1	1 (The internal optical coupler corresponding to the input is conducted.)	Enabled (ON)

Note:

- If P0.04 is set to 1, but the external terminal command status is changed from 1 to 0, the drive is disabled, that is, P0.04 is changed to 0 automatically.
- The method for setting this parameter on the LED panel is different from that for setting other parameters. You can use only the **SET** key to switch between 0 and 1. The **UP/DOWN** key is invalid on the screen for setting this parameter.

P0.04*	Data size	16bit	Data format	DEC
	Modbus address	1008, 1009	CANopen address	0x2004, 0x00

P0.05	Jogging speed	Setting range	Default	Unit	Applicable mode		
		0–1000	200	r/min	P	S	T

This parameter specifies the jogging speed. For details, see 5.2.5.2 "Jogging test". During the jogging process, the ACC/DEC time parameters P0.54, P0.55, P0.56, P0.57 function, and the motor accelerates, decelerates, starts, or stops based on the settings.

P0.05	Data size	16bit	Data format	DEC
	Modbus address	1010, 1011	CANopen address	0x2005, 0x00

P0.06 ¹	Numerator of frequency division output coefficient	Setting range	Default	Unit	Applicable mode		
		0–(2 ³¹ -1)	10000	-	P	S	T
P0.07 ¹	Denominator of frequency division output coefficient	Setting range	Default	Unit	Applicable mode		
		1–(2 ³¹ -1)	131072	-	P	S	T

By setting the numerator and denominator of the frequency division output coefficient, the position

from the encoder feedback can be frequency divided by any integer or decimal fraction and then output through the encoder pulse output signal terminals (OA+, OA-, OB+ and OB-, corresponding to pins 44, 43, 41, and 42) of the CN1 plug.

$$\text{Drive output pulses} = \frac{P0.06}{P0.07} \times \text{Encoder resolution}$$

Note:

1. In position control mode, if the encoder output signal of the upper-level servo motor is used as the position pulse command input of the current-level servo drive, that is, executing the master/slave follow-up of the start/stop type, in order to ensure high positioning accuracy of the current-level servo drive, the frequency division coefficient must be 1:1. Otherwise, the accuracy of master/slave position follow-up is affected.
2. By default, P0.07 is 131072 and P0.06 is 10000, indicating the encoder pulse output terminal outputs 10000 pulse signals each time the motor rotates a circle. If P0.06 is changed to 5000, the encoder pulse output terminal outputs 5000 pulse signals in the same situation.

P0.06 ¹	Data size	32bit	Data format	DEC
	Modbus address	1012, 1013	CANopen address	0x2006, 0x00
P0.07 ¹	Data size	32bit	Data format	DEC
	Modbus address	1014, 1015	CANopen address	0x2007, 0x00

P0.08 ¹	Reverse frequency division output	Setting range	Default	Unit	Applicable mode		
		0-1	0	-	P	S	T

This parameter specifies whether to reverse the phase-B pulse logic of pulse output. Then the phase relationship between phase-A pulses and phase-B pulses can be changed.

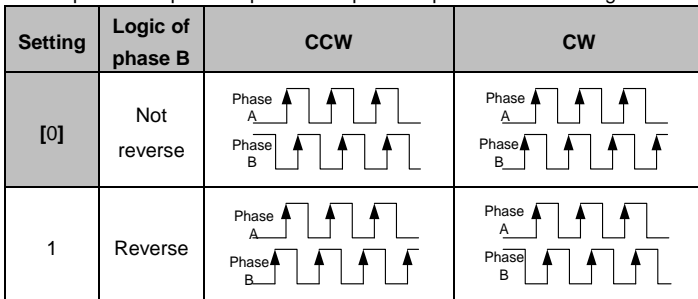

P0.08 ¹	Data size	16bit	Data format	DEC
	Modbus address	1016, 1017	CANopen address	0x2008, 0x00

P0.09	Torque limit mode	Setting range	Default	Unit	Applicable mode
-------	-------------------	----------------------	----------------	-------------	------------------------

		0-6	1	-	P	S	
--	--	-----	---	---	---	---	--

This parameter specifies the torque limit mode.

Setting	Forward direction	Reverse direction
0	Torque limit (analog input 0V-10V)	Torque limit (analog input -10V-0V)
[1]	Maximum torque limit 1 (P0.10)	
2	Maximum torque limit 1 (P0.10)	Maximum torque limit 2 (P0.11)
3	TLC OFF → Maximum torque limit 1 (P0.10) TLC ON → Maximum torque limit 2 (P0.11)	
4	Forward torque limit (analog input 0V-10V)	Reverse torque limit (analog input -10V-0V)
5	Forward torque limit (analog input 0V-10V)	
6	Forward torque limit (analog input 0V-10V)	

Note: If P0.09 is set to 3, torque switching does not take effect immediately, but limited by the settings of P4.51 and P4.52. The torque switching limit is shown in the following:

$$T_a[\text{ms}] = |P0.11[\%] - P0.10[\%]| \times P4.51[\text{ms}/100\%]/100$$

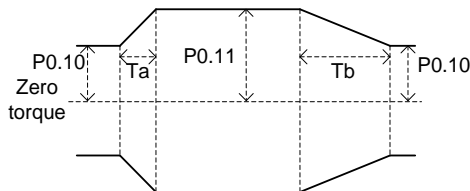

$$T_b[\text{ms}] = |P0.10[\%] - P0.11[\%]| \times P4.52[\text{ms}/100\%]/100$$

P0.09	Data size	16bit	Data format	DEC
	Modbus address	1018, 1019	CANopen address	0x2009, 0x00

P0.10	Max. torque limit 1	Setting range	Default	Unit	Applicable mode		
		0.0-500.0	300.0	%	P	S	T
P0.11	Max. torque limit 2	Setting range	Default	Unit	Applicable mode		
		0.0-500.0	300.0	%	P	S	

This group of parameter specifies the maximum torque that the servo motor can output. Assuming that the rated torque of the servo motor is 100%, the setting is a percentage of the rated torque. If the absolute value of the torque command is great than the setting, the actual output torque is limited by the setting.

Note:

- This group of parameter is used with P0.09.
- In torque mode, the torque limit is determined by P0.10.

P0.10	Data size	16bit	Data format	DEC
	Modbus address	1020, 1021	CANopen address	0x200A, 0x00
P0.11	Data size	16bit	Data format	DEC
	Modbus address	1022, 1023	CANopen address	0x200B, 0x00

P0.12	Input selection for 3PH input-type servo power supply	Setting range	Default	Unit	Applicable mode		
		0-1	0	-	P	S	T

This parameter specifies the input type of a three-phase input-type servo drive power supply.

Setting	Meaning
[0]	Three-phase input
1	Single-phase input

P0.12	Data size	16bit	Data format	DEC			
	Modbus address	1024, 1025	CANopen address	0x200C, 0x00			
P0.13 ¹	External brake resistor power	Setting range	Default	Unit	Applicable mode		
		0-5000	200	W	P	S	T
P0.14 ¹	External brake resistor resistance	Setting range	Default	Unit	Applicable mode		
		1-1000	60	Ω	P	S	T

If an external brake resistor is used, the settings of the parameters must be the same as the power and resistance of the external brake resistor.

Note:

Brake overload detection should be used with P4.34. If P4.34 is set to 2, the brake overload detection logic uses the external brake resistor parameters to execute fault detection. If this group of parameter does not match the power and resistance of the external brake resistor, the brake overload fault (Er07-0) may be reported by mistake or even the brake resistor may be burnt down. The regenerative brake overload protection time of the external brake resistor is in direct proportion to the two parameters and is in inverse proportion to the brake rate during actual running. The two parameters are invalid when P4.34 is not 2.

P0.13 ¹	Data size	16bit	Data format	DEC
	Modbus address	1026, 1027	CANopen address	0x200D, 0x00
P0.14 ¹	Data size	16bit	Data format	DEC
	Modbus address	1028, 1029	CANopen address	0x200E, 0x00

P0.15	Default monitored parameters	Setting range	Default	Unit	Applicable mode		
		0-22	0	-	P	S	T

This parameter specifies the status parameters that are monitored upon power-on:

Setting	Meaning	Display	Unit
[0]	Motor speed	SPdFb	r/min
1	Speed command	SPdcNd	r/min
2	Accumulated feedback pulses	PLS.Fb	reference unit
3	Pulse command accumulation	PLScNd	reference unit
4	Residual pulses	PLSEr1	reference unit
5	Hybrid control deviation	PLSEr2	reference unit
6	Current torque	trqFb	%
7	Main circuit DC voltage	Ubus1	V
8	Output voltage	UoUt	Vrms
9	Output current	IoUt	Arms
10	Drive temperature	ndLTnP	°C
11	Torque limit	trqLnt	%
12	Encoder feedback value	Enc.Fb	pulse
13	Rotor position relative to phase-Z pulse	Enc.Abs	pulse
14	Load inertia ratio	J-r	%
15	Output power	POdEr	%
16	Motor load ratio	LoAd-r	%
17	Numerator of actual electronic gear ratio	nUN	-
18	Denominator of actual electronic gear ratio	dEn	-
19	Pulse-corresponded speed command	PLSSPd	r/min
20	Instantaneous speed	SPdFb1	r/min
21	PTP state	PtPStS	-

P0.15	Data size	16bit	Data format	DEC
	Modbus address	1030, 1031	CANopen address	0x200F, 0x00

P0.16	Parameter modification lock	Setting range	Default	Unit	Applicable mode		
		0-1	0	-	P	S	T

This parameter specifies whether to lock the function of modifying parameters (excluding P0.16 and parameters that are not be saved after power-off), preventing maloperation.

Setting	Through the panel	Through communication
[0]	Unlock the function	Unlock the function
1	Lock the function	Lock the function

P0.16	Data size	16bit	Data format	DEC
	Modbus address	1032, 1033	CANopen address	0x2010, 0x00

P0.17	Mode for writing to EEPROM	Setting range	Default	Unit	Applicable mode		
		0-1	0	-	P	S	T

This parameter specifies the mode for writing parameter settings that are modified through the panel to the EEPROM.

Setting	Meaning
[0]	Individually (that is, automatically saved after a modification)
1	In batches (that is, modifications saved in batches if P4.91 is set to 1)

P0.17	Data size	16bit	Data format	DEC
	Modbus address	1034, 1035	CANopen address	0x2011, 0x00

P0.18*	Factory password	Setting range	Default	Unit	Applicable mode		
		0-65536	0	-	P	S	T

This parameter enables you to view factory parameters and modify menus.

P0.18*	Data size	16bit	Data format	DEC
	Modbus address	1036, 1037	CANopen address	0x2012, 0x00

P0.19	Main circuit power input type	Setting range	Default	Unit	Applicable mode		
		0-65536	0	-	P	S	T

This parameter specifies the power input type for the main circuit.

Setting	Meaning
[0]	Terminals L1, L2, and L3 input AC power.
1	Terminals + and - input DC power.

P0.19	Data size	16bit	Data format	DEC
	Modbus address	1038, 1039	CANopen address	0x2013, 0x00

6.1.2 Position control

P0.20 ¹	Position command source	Setting range	Default	Unit	Applicable mode													
		0–4	0	-	P													
<p>This parameter specifies the position command source in the position, fully-closed loop, and hybrid position control modes.</p> <table border="1"> <thead> <tr> <th>Setting</th> <th>Meaning</th> </tr> </thead> <tbody> <tr> <td>[0]</td> <td>Pulse input</td> </tr> <tr> <td>1</td> <td>Communication bus input</td> </tr> <tr> <td>2</td> <td>PTP control</td> </tr> <tr> <td>3</td> <td>Reserved</td> </tr> <tr> <td>4</td> <td>Second encoder input</td> </tr> </tbody> </table>							Setting	Meaning	[0]	Pulse input	1	Communication bus input	2	PTP control	3	Reserved	4	Second encoder input
Setting	Meaning																	
[0]	Pulse input																	
1	Communication bus input																	
2	PTP control																	
3	Reserved																	
4	Second encoder input																	
P0.20 ¹	Data size	16bit	Data format	DEC														
	Modbus address	1040, 1041	CANopen address	0x2014, 0x00														

P0.22 ¹	Pulses per motor resolution	Setting range	Default	Unit	Applicable mode	
		0–(2 ³¹ -1)	10000	reference unit	P	
<p>This parameter specifies the number of pulses required per motor resolution.</p> <p>Note: If P0.22 is set to a non-zero value, the settings of P0.25–P0.29 are invalid. If a 17-bit or 20-bit encoder is used together, you are recommended to set a greater value to achieve higher accuracy.</p>						
P0.22 ¹	Data size	32bit	Data format	DEC		
	Modbus address	1044, 1045	CANopen address	0x2016, 0x00		

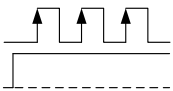
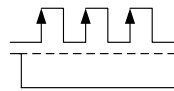
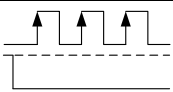
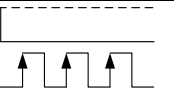
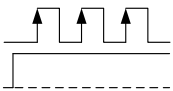
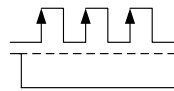
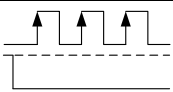
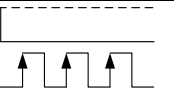
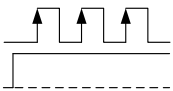
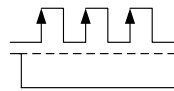
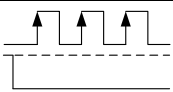
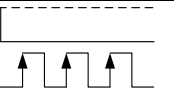
P0.23 ¹	Pulse input mode	Setting range	Default	Unit	Applicable mode																		
		0–2	0	-	P																		
<p>This parameter specifies the pulse input mode. There are three pulse input modes available.</p> <table border="1"> <thead> <tr> <th rowspan="2">Setting</th> <th rowspan="2">Meaning</th> <th rowspan="2">Signal form</th> <th colspan="2">Diagram</th> </tr> <tr> <th>CCW</th> <th>CW</th> </tr> </thead> <tbody> <tr> <td>[0]</td> <td>Pulse + sign</td> <td>Pulse+ Sign</td> <td></td> <td></td> </tr> <tr> <td>1</td> <td>CCW/CW pulse train</td> <td>CW+CCW</td> <td></td> <td></td> </tr> </tbody> </table>							Setting	Meaning	Signal form	Diagram		CCW	CW	[0]	Pulse + sign	Pulse+ Sign			1	CCW/CW pulse train	CW+CCW		
Setting	Meaning	Signal form	Diagram																				
			CCW	CW																			
[0]	Pulse + sign	Pulse+ Sign																					
1	CCW/CW pulse train	CW+CCW																					

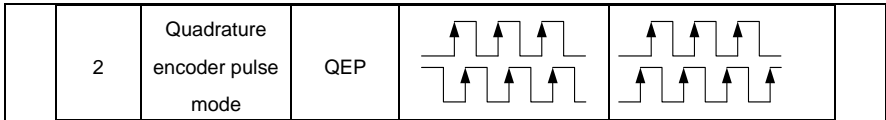

Note:

The pulse direction specified by this parameter can be reversed by P0.24¹. See P0.24¹ for details.

P0.23 ¹	Data size	16bit	Data format	DEC
	Modbus address	1046, 1047	CANopen address	0x2017, 0x00

P0.24 ¹	Reverse pulse input direction	Setting range	Default	Unit	Applicable mode		
		0-1	0	-	P		

By setting this parameter, the input pulse direction can be reversed. At this time, the actual output speed direction of the servo drive is opposite to the direction specified by P0.23.

Setting	Meaning
[0]	The pulse input direction remains unchanged.
1	The pulse input direction and original input direction are reverse.

P0.24 ¹	Data size	16bit	Data format	DEC
	Modbus address	1048, 1049	CANopen address	0x2018, 0x00

P0.25	Numerator of electronic gear ratio 1	Setting range	Default	Unit	Applicable mode		
		$0-(2^{31}-1)$	0	-	P		
P0.26	Denominator of electronic gear ratio	Setting range	Default	Unit	Applicable mode		
		$1-(2^{31}-1)$	10000	-	P		
P0.27	Numerator of electronic gear ratio 2	Setting range	Default	Unit	Applicable mode		
		$0-(2^{31}-1)$	0	-	P		
P0.28	Numerator of electronic gear ratio 3	Setting range	Default	Unit	Applicable mode		
		$0-(2^{31}-1)$	0	-	P		
P0.29	Numerator of electronic gear ratio 4	Setting range	Default	Unit	Applicable mode		
		$0-(2^{31}-1)$	0	-	P		

Electronic gear ratio concept: For any pulse input, the quantity and frequency of pulse actually received by the drive can be changed by multiplying a certain coefficient. This coefficient is

electronic gear ratio. It can be divided into two parts: numerator and denominator:

$$\text{Electronic gear ratio} = g1 / g2$$

Of which,

$g1$: indicates the numerator of the electronic gear ratio

$g2$: indicates the denominator of the electronic gear ratio;

The following is the schematic diagram for the electronic gear ratio:

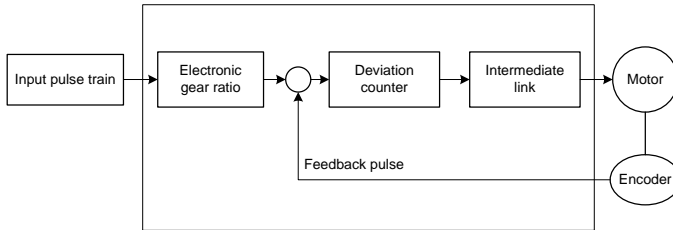

Example: The following is an example where 1 pulse is equivalent to a feed rate of $10\mu\text{m}$:

Mechanical specifications:

Feed of the ball screw $Pb = 10\text{mm}$

DEC ratio $n = 3/5$

Resolution of the servo motor encoder = 10000

The electronic gear ratio is as follows:

$$\frac{g1}{g2} = \Delta l_0 \cdot \frac{Pt}{\Delta S} = \Delta l_0 \cdot \frac{Pt}{n \cdot Pb} = 10 \times 10^{-3} \cdot \frac{10000}{(3/5) \cdot 10} = \frac{50}{3}$$

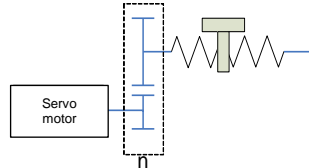

In the expression, Δl_0 : Feed corresponding to each pulse (mm/pulse)

ΔS : Feed corresponding to each rotation motor (mm/rotation)

In this example: $g1 = 50$, $g2 = 3$

The servo drive has four groups of electronic gear ratio. You can determine which parameters are selected from P0.25, P0.26, P0.27, P0.28, and P0.29 to make up the electronic gear ratio through the electronic gear ratio selection terminals SC1 and SC2 of the CN1 plug.

SC1	SC2	In position mode
0	0	Numerator of electronic gear ratio 1
1	0	Numerator of electronic gear ratio 2
0	1	Numerator of electronic gear ratio 3
1	1	Numerator of electronic gear ratio 4

Note:

- This group of parameters is valid only when P0.22¹ is 0.
- If SC1 and SC2 are used for electronic gear ratio switching, P4.10 must be set to 0.

P0.25	Data size	32bit	Data format	DEC
	Modbus address	1050, 1051	CANopen address	0x2019, 0x00
P0.26	Data size	32bit	Data format	DEC

	Modbus address	1052, 1053	CANopen address	0x201A, 0x00
P0.27	Data size	32bit	Data format	DEC
	Modbus address	1054, 1055	CANopen address	0x201B, 0x00
P0.28	Data size	32bit	Data format	DEC
	Modbus address	1056, 1057	CANopen address	0x201C, 0x00
P0.29	Data size	32bit	Data format	DEC
	Modbus address	1058, 1059	CANopen address	0x201D, 0x00

P0.33 ²	Position command smooth filter time	Setting range	Default	Unit	Applicable mode		
		0.0–1000.0	0.0	ms	P		

This parameter specifies the time constant for a first-order low pass filter corresponding to a position command, reducing the mechanical shock caused by sudden input pulse command frequency changes.

See the following figure:

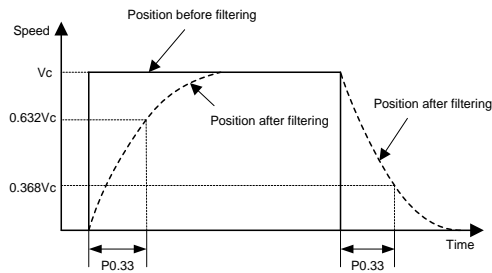

P0.33 ²	Data size	16bit	Data format	DEC
	Modbus address	1066, 1067	CANopen address	0x2021, 0x00

P0.34 ²	Position command FIR filter time	Setting range	Default	Unit	Applicable mode		
		0.0–1000.0	0.0	ms	P		

This parameter specifies the time constant for the FIR filter corresponding to a position command, reducing the mechanical shock caused by sudden input pulse command frequency changes. See the following figure:

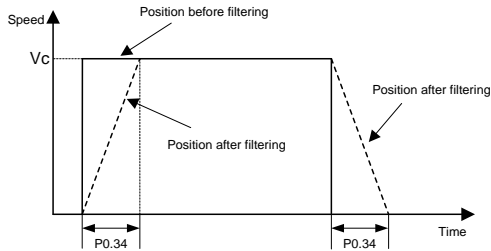

Note: If this parameter is modified during servo running, the modification takes effect after stop.

P0.34 ²	Data size	16bit	Data format	DEC
	Modbus address	1068, 1069	CANopen address	0x2022, 0x00

P0.35	Software limit in CCW position control	Setting range	Default	Unit	Applicable mode		
		$-(2^{31}-1)-(2^{31}-1)$	0	reference unit	P		

This parameter specifies the software limit in CCW position control.

If P0.35 is 0 and P0.36 is 0, software limit is invalid.

Note: The software limit function is valid only when this parameter is greater than P0.36.

P0.35	Data size	32bit	Data format	DEC
	Modbus address	1070, 1071	CANopen address	0x2023, 0x00

P0.36	Software limit in CW position control	Setting range	Default	Unit	Applicable mode		
		$-(2^{31}-1)-(2^{31}-1)$	0	reference unit	P		

This parameter specifies the software limit in CW position control.

If P0.35 is 0 and P0.36 is 0, software limit is invalid.

Note: The software limit function is valid only when this parameter is less than P0.35.

P0.36	Data size	32bit	Data format	DEC
	Modbus address	1072, 1073	CANopen address	0x2024, 0x00

P0.37	Position command mode	Setting range	Default	Unit	Applicable mode		
		0-1	0	-	P		

This parameter specifies the position command mode when P0.20 [Position command source] is set to 1, and it is invalid in other modes.

Setting	Meaning
[0]	Incremental (The position command input is the variation relative to the current position.)
1	Absolute (The position command input is the target position.)

P0.37	Data size	16bit	Data format	DEC
	Modbus address	1074, 1075	CANopen address	0x2025, 0x00

P0.38	Enabling fully-closed loop	Setting range	Default	Unit	Applicable mode	
		0-2	0	-	P	

This parameter specifies whether to enable the fully-closed loop function.

When this parameter is set to 2, the switching between fully-closed loop and half-closed loop can be performed through the 0x34 or 0x134 I/O port.

Note: The electronic gear ratio definition for fully-closed loop running that is enabled when this parameter is set to 1 is different from the electronic gear ratio definition for fully-closed loop running that is enabled when this parameter is set to 2. For details, see section 7.2.1.

Setting	Meaning
[0]	Disable
1	Enable fully-closed loop
2	Enable switching between fully-closed loop and half-closed loop

P0.38	Data size	16bit	Data format	DEC
	Modbus address	1076, 1077	CANopen address	0x2026, 0x00

6.1.3 Speed and torque control

P0.40	Speed command source	Setting range	Default	Unit	Applicable mode	
		0-5	1	-	S	

This parameter specifies the command source in speed control.

Setting	Input mode	Description																																													
0	Internal speed	P3.00–P3.07 can be used to control the internal multi-step speed (SPD1 is 0x00A, SPD2 is 0x00B, SPD3 is 0x00C):																																													
		<table border="1"> <thead> <tr> <th>SPD3</th> <th>SPD2</th> <th>SPD1</th> <th>Parameter</th> <th>Speed mode</th> </tr> </thead> <tbody> <tr> <td>0</td> <td>0</td> <td>0</td> <td>P0.46</td> <td>Internal speed 1</td> </tr> <tr> <td>0</td> <td>0</td> <td>1</td> <td>P0.47</td> <td>Internal speed 2</td> </tr> <tr> <td>0</td> <td>1</td> <td>0</td> <td>P0.48</td> <td>Internal speed 3</td> </tr> <tr> <td>0</td> <td>1</td> <td>1</td> <td>P0.49</td> <td>Internal speed 4</td> </tr> <tr> <td>1</td> <td>0</td> <td>0</td> <td>P0.50</td> <td>Internal speed 5</td> </tr> <tr> <td>1</td> <td>0</td> <td>1</td> <td>P0.51</td> <td>Internal speed 6</td> </tr> <tr> <td>1</td> <td>1</td> <td>0</td> <td>P0.52</td> <td>Internal speed 7</td> </tr> <tr> <td>1</td> <td>1</td> <td>1</td> <td>P0.53</td> <td>Internal speed 8</td> </tr> </tbody> </table>	SPD3	SPD2	SPD1	Parameter	Speed mode	0	0	0	P0.46	Internal speed 1	0	0	1	P0.47	Internal speed 2	0	1	0	P0.48	Internal speed 3	0	1	1	P0.49	Internal speed 4	1	0	0	P0.50	Internal speed 5	1	0	1	P0.51	Internal speed 6	1	1	0	P0.52	Internal speed 7	1	1	1	P0.53	Internal speed 8
		SPD3	SPD2	SPD1	Parameter	Speed mode																																									
		0	0	0	P0.46	Internal speed 1																																									
		0	0	1	P0.47	Internal speed 2																																									
		0	1	0	P0.48	Internal speed 3																																									
		0	1	1	P0.49	Internal speed 4																																									
		1	0	0	P0.50	Internal speed 5																																									
		1	0	1	P0.51	Internal speed 6																																									
1	1	0	P0.52	Internal speed 7																																											
1	1	1	P0.53	Internal speed 8																																											
See the descriptions for P0.46–P0.53.																																															
[1]	Analog input	You need to set either P3.26 [Function of AI 1] or P3.27 [Function of AI 2] to 3 [Speed command] and set associated parameters according to the actual situation.																																													
2	Bus input	The communication bus interface can be used to receive speed commands from the upper computer. If P4.10 is 1 [Bus input], the motor speed can be changed by P4.13 [Bus speed command]. See the descriptions for P4.10 and P4.13.																																													
3	Reserved	-																																													
4	Reserved	-																																													
5	High-resolution on internal speed	Accurate to 0.1 r/min																																													

P0.40	Data size	16bit	Data format	DEC
	Modbus address	1080, 1081	CANopen address	0x2028, 0x00

P0.41	Speed command direction setting	Setting range	Default	Unit	Applicable mode
		0–1	0	-	S

This parameter specifies the method for specifying the direction in a speed command when P0.40 is 0 or 1, and the speed command symbol is S-SIGN.

Setting	Internal speed/AI	Speed command symbol	Speed command direction
[0]	Positive speed	0V–10V	Not work
	Negative speed	-10V–0V	Not work
1	Not work	Valid	CCW

		Not work	Invalid	CW
P0.41	Data size	16bit	Data format	DEC
	Modbus address	1082, 1083	CANopen address	0x2029, 0x00

P0.42	Gain of AI 1	Setting range	Default	Unit	Applicable mode		
		10–2000	100	[P3.26 unit]/V	P	S	T

This parameter specifies the gain of analog input 1, the gain unit is associated with P3.26.

Note:

- Analog input 1 indicates the signal input from the terminals (that is, AD1 and GND, corresponding to pin 1 and pin 5) of analog input 1 of the CN1 plug.
- The voltage only in the -10V~+10V range can be applied to the connection between AD1 and GND. Otherwise, the drive may be damaged.

Application example:

1. The function of analog input 1 is speed command.
2. The voltage of analog input 1 corresponds to the conversion gain of the motor command speed.
3. P0.40 is set to 1.
4. The relationship between the voltage of analog input 1 and speed command is as follows: Every 1V voltage corresponds to the 100 r/min speed by default.

Actual speed command = Analog input voltage x P0.42

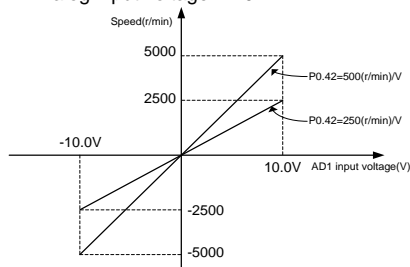

Note:

- This parameter is valid only when P0.40 is 1.
- Set this parameter according to the motor working condition. If this parameter is set to a large value, the motor speed may fluctuate sharply.

P0.42	Data size	32bit	Data format	DEC
	Modbus address	1084, 1085	CANopen address	0x202A, 0x00

P0.43	Reverse of AI 1	Setting range	Default	Unit	Applicable mode		
		0–1	0	-	P	S	T

This parameter specifies the voltage polarity of analog input 1.

Setting	Actual detection result	
[0]	Positive polarity	[+Voltage]→[Positive value],[- Voltage]→[Negative value]
1	Negative polarity	[+Voltage]→[Negative value],[- Voltage]→[Positive value]

P0.43	Data size	16bit	Data format	DEC
	Modbus address	1086, 1087	CANopen address	0x202B, 0x00

P0.45	Dead zone of AI 1	Setting range	Default	Unit	Applicable mode		
		0.000–3.000	0.000	V	P	S	T

If the absolute voltage value of analog input 1 falls in the range of this parameter, the corresponding command value is 0.

P0.45	Data size	16bit	Data format	DEC
	Modbus address	1090, 1091	CANopen address	0x202D, 0x00

P0.46	Internal speed 1/speed limit 1	Setting range	Default	Unit	Applicable mode		
		-20000–20000	100	r/min		S	T
P0.47	Internal speed 2/speed limit 2	Setting range	Default	Unit	Applicable mode		
		-20000–20000	0	r/min		S	T
P0.48	Internal speed 3/speed limit 3	Setting range	Default	Unit	Applicable mode		
		-20000–20000	0	r/min		S	T
P0.49	Internal speed 4/speed limit 4	Setting range	Default	Unit	Applicable mode		
		-20000–20000	0	r/min		S	T
P0.50	Internal speed 5	Setting range	Default	Unit	Applicable mode		
		-20000–20000	0	r/min		S	
P0.51	Internal speed 6	Setting range	Default	Unit	Applicable mode		
		-20000–20000	0	r/min		S	
P0.52	Internal speed 7	Setting range	Default	Unit	Applicable mode		
		-20000–20000	0	r/min		S	
P0.53	Internal speed 8	Setting range	Default	Unit	Applicable mode		
		-20000–20000	0	r/min		S	

The servo drive supports the 8-step internal speed commands and 4-step internal speed limits.

Control mode	Setting of P0.40	SPD3	SPD2	SPD1	Associated parameter and setting
Speed	0	0	0	0	P0.46 Internal speed 1
		0	0	1	P0.47 Internal speed 2
		0	1	0	P0.48 Internal speed 3
		0	1	1	P0.49 Internal speed 4
		1	0	0	P0.50 Internal speed 5
		1	0	1	P0.51 Internal speed 6
		1	1	0	P0.52 Internal speed 7
		1	1	1	P0.53 Internal speed 8
Torque	0	0	0	0	P0.46 Speed limit 1
		0	0	1	P0.47 Speed limit 2
		0	1	0	P0.48 Speed limit 3
		0	1	1	P0.49 Speed limit 4

Note:

SPD1, SPD2, SPD3 are the digital inputs of internal speed commands 1, 2, and 3 (corresponding to 0x00A, 0x00B, and 0x00C).

0: OFF (The internal optical coupler corresponding to the input is not conducted.)

1: ON (The internal optical coupler corresponding to the input is conducted.)

The speed limits depend on the absolute values of the parameters and, the directions are the same as those in torque commands.

P0.46	Data size	16bit	Data format	DEC
	Modbus address	1092, 1093	CANopen address	0x202E, 0x00
P0.47	Data size	16bit	Data format	DEC
	Modbus address	1094, 1095	CANopen address	0x202F, 0x00
P0.48	Data size	16bit	Data format	DEC
	Modbus address	1096, 1097	CANopen address	0x2030, 0x00
P0.49	Data size	16bit	Data format	DEC
	Modbus address	1098, 1099	CANopen address	0x2031, 0x00
P0.50	Data size	16bit	Data format	DEC
	Modbus address	1100, 1101	CANopen address	0x2032, 0x00
P0.51	Data size	16bit	Data format	DEC
	Modbus address	1102, 1103	CANopen address	0x2033, 0x00
P0.52	Data size	16bit	Data format	DEC
	Modbus address	1104, 1105	CANopen address	0x2034, 0x00
P0.53	Data size	16bit	Data format	DEC
	Modbus address	1106, 1107	CANopen address	0x2035, 0x00

P0.54	ACC time	Setting range	Default	Unit	Applicable mode	
		0-30000	0	ms		S
P0.55	DEC time	Setting range	Default	Unit	Applicable mode	
		0-30000	0	ms		S

ACC/DEC time is the time taken to accelerate from 0 r/min to the rated (3000 r/min by default) speed in the given command or decelerates from the rated speed to 0 r/min. If the given speed is not equal to the rated speed, the actual ACC/DEC time is the set ACC/DEC time multiplied by the ratio of the given speed to the rated speed. If the speed command is negative, the absolute value is used to calculate the ACC/DEC time.

Example: If the given speed is 2000 r/min, the rated speed is 3000 r/min, and the ACC/DEC time (P0.54/P0.55) is set to 1500, then the actual ACC time t_1 is $1500 \times (2000/3000) = 1000\text{ms}$ and the DEC time t_2 is $1500 \times (2000/3000) = 1000\text{ms}$. See the following figure:

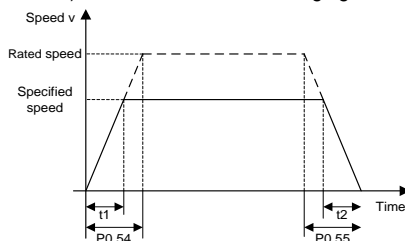

Note: This group of parameter is valid only in speed mode.

P0.54	Data size	32bit	Data format	DEC
	Modbus address	1108, 1109	CANopen address	0x2036, 0x00
P0.55	Data size	32bit	Data format	DEC
	Modbus address	1110, 1111	CANopen address	0x2037, 0x00

P0.56	S-curve ACC time	Setting range	Default	Unit	Applicable mode	
		0-1000	0	ms		S
P0.57	S-curve DEC time	Setting range	Default	Unit	Applicable mode	
		0-1000	0	ms		S

In a rated-speed command, this group of parameter is used to set the duration of the circular arc segments in the S curve, thus achieving the goal of smooth starting. The S-curve ACC/DEC time is shown in the following figure:

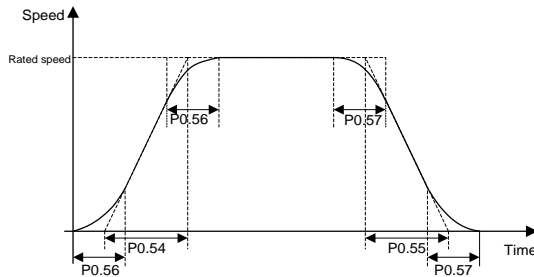

Note:

- This group of parameter is valid only in speed mode.
- This group of parameter is invalid when the speed command source is AI.
- If the setting of P0.54 is less than that of P0.56 and P0.56 is not 0, P0.54 is equal to P0.56 during the actual running.
- If the setting of P0.55 is less than that of P0.57 and P0.57 is not 0, P0.55 is equal to P0.57 during the actual running.

P0.56	Data size	16bit	Data format	DEC
	Modbus address	1112, 1113	CANopen address	0x2038, 0x00
P0.57	Data size	16bit	Data format	DEC
	Modbus address	1114, 1115	CANopen address	0x2039, 0x00

P0.58	Zero speed clamp mode	Setting range	Default	Unit	Applicable mode	
		0-3	0	-	S	T

This parameter specifies the zero speed clamp mode.

Setting	In position command mode
[0]	Invalid (The zero speed clamp input is ignored.)
1	If the zero speed clamp control signal is valid, the speed command is forcibly set to 0.
2	If the zero speed clamp control signal is valid, the speed command is forcibly set to 0, the position control mode is used when the actual motor speed becomes less than P0.59 [Speed threshold in zero speed clamp], and the servo is locked at this position.
3	If the zero speed clamp control signal is valid, the position control mode is used when the actual motor speed becomes less than P0.59 minus 10 r/min, and the servo is locked at this position.

Note:

- After configuring any of parameters P3.00–P3.07 with the zero speed clamp (0x00D) function, you can use the zero speed clamp terminals of the CN1 plug for control or use P4.19 [Zero speed clamp command] for control. The input settings of P3.00–P3.07 are described as follows:
 0: Disable zero speed clamp.
 1: Enable zero speed clamp.
- In torque control mode, the settings 0 and 1 are valid, and 2 and 3 have the same function as 1.

P0.58	Data size	16bit	Data format	DEC
	Modbus address	1116, 1117	CANopen address	0x203A, 0x00

P0.59	Zero speed clamp speed threshold	Setting range	Default	Unit	Applicable mode		
		10–20000	30	r/min		S	

This parameter specifies the speed threshold for switching to position control when P0.58 is 2 or 3. When P0.58 is 3, there is a 10 r/min delay detected.

P0.59	Data size	16bit	Data format	DEC
	Modbus address	1118, 1119	CANopen address	0x203B, 0x00

P0.60	Torque command source	Setting range	Default	Unit	Applicable mode		
		0–3	1	-			T

This parameter specifies the command source in torque control.

Setting	Input mode	Description
0	Internally specified	Specified by P0.66.
[1]	Analog input	You need to set P3.26 [Function of AI 1] or P3.27 [Function of AI 2] to 4 [Torque command] and set associated parameters according to the actual situation.
2	Bus input	The communication bus interface can be used to receive torque commands from the upper computer. If P4.10 is 1 [Bus input], the motor speed can be changed by P4.14 [Bus torque command]. See the descriptions for P4.10 and P4.14.
3	Reserved	-

P0.60	Data size	16bit	Data format	DEC
	Modbus address	1120, 1121	CANopen address	0x203C, 0x00

P0.61	Torque command direction setting	Setting range	Default	Unit	Applicable mode		
		0-1	0	-			T

This parameter specifies the method for specifying the direction in a torque command.

Setting	Meaning
[0]	The input sign of the torque command specifies the direction. For example, Torque command input [+] indicates forward, while [-] indicates reverse.
1	The torque command sign [0x00F] of the digital input function is used to specify the direction. 1: forward 0: reverse

Note: 0x00F is valid when the input is a low electrical level, while 0x10F is valid when the input is a high electrical level.

P0.61	Data size	16bit	Data format	DEC
	Modbus address	1122, 1123	CANopen address	0x203D, 0x00

P0.62	Gain of AI 2	Setting range	Default	Unit	Applicable mode		
		0-2000	100	[P3.27 unit]/V	P	S	T

This parameter specifies the gain of analog input 2. The gain unit is associated with P3.27.

Note: Analog input 2 indicates the signal input from the analog speed/speed limit terminals (AD2 and GND, corresponding to pin 20 and pin 19) of the CN1 plug.

Application example:

1. The function of analog input 2 is torque command.
2. The voltage of analog input 2 corresponds to the conversion gain of the motor torque command.
3. This parameter is valid only when P0.60 is 1.
4. The relationship between the voltage of analog input 2 and torque command is as follows: The torque corresponding to every 1V voltage is 10% of the rated torque by default.

Actual torque command = Analog input voltage x P0.62

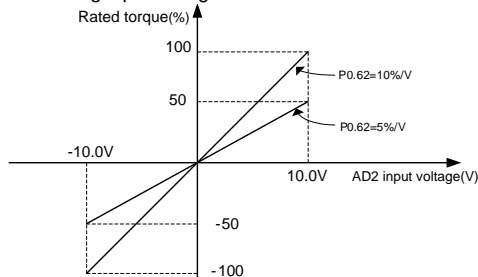

Note:
Set this parameter according to the motor working condition. If this parameter is set to a large value, the motor speed may fluctuate sharply.

P0.62	Data size	32bit	Data format	DEC
	Modbus address	1124, 1125	CANopen address	0x203E, 0x00

P0.63	Reverse of AI 2	Setting range	Default	Unit	Applicable mode		
		0-1	0	-	P	S	T

This parameter specifies the voltage polarity of analog input 2.

Setting	Actual detection result	
[0]	Positive polarity	[+Voltage] → [Positive value], [-Voltage] → [Negative value]
1	Negative polarity	[+Voltage] → [Negative value], [-Voltage] → [Positive value]

P0.63	Data size	16bit	Data format	DEC
	Modbus address	1126, 1127	CANopen address	0x203F, 0x00

P0.65	Dead zone of AI 2	Setting range	Default	Unit	Applicable mode		
		0.000-3.000	0.000	V	P	S	T

If the absolute voltage value of analog input 2 falls in the range of this parameter, the corresponding command value is 0.

P0.65	Data size	16bit	Data format	DEC
	Modbus address	1130, 1131	CANopen address	0x2041, 0x00

P0.66	Internal torque command	Setting range	Default	Unit	Applicable mode		
		-500.0-500.0	0.0	%			T

This parameter specifies the internal torque reference. If the servo motor rated torque is considered as 100%, the setting of this parameter is a percentage of the servo motor rated torque.

Note:

- If the absolute value of this parameter is greater than maximum torque limit 1 (P0.10), the output torque is the setting of P0.10 and the direction is the same as this parameter.
- In torque mode, this parameter is valid only when P0.60 is 0.

P0.66	Data size	16bit	Data format	DEC
	Modbus address	1132, 1133	CANopen address	0x2042, 0x00

P0.67	Speed limit mode	Setting range	Default	Unit	Applicable mode		
		0-1	1	-			T

This parameter specifies the speed limit mode for torque control.

Setting	Meaning
0	The analog input is selected as the speed limit source. You need to set either P3.26 [Function of AI 1] or P3.27 [Function of AI 2] to 1 [Speed limit] and set associated parameters according to the actual situation.
[1]	Internal speed limit, selected from P0.46-P0.49.

Note: The speed limit is internally processed as an absolute value, and the actual sign of the limit is the same as that of the torque command.

P0.67	Data size	16bit	Data format	DEC
	Modbus address	1134, 1135	CANopen address	0x2043, 0x00

P0.68	Torque command ramp time	Setting range	Default	Unit	Applicable mode		
		0-10000	0	ms			T

This parameter is used to modify the planning curve when the torque command input changes. This parameter indicates the time taken to rise from 0 to 100% of the rated torque.

P0.68	Data size	16bit	Data format	DEC
	Modbus address	1136, 1137	CANopen address	0x2044, 0x00

P0.69	DEC time for quick stop	Setting range	Default	Unit	Applicable mode		
		0-10000	500	ms	P	S	T

This parameter specifies the DEC time for quick stop. It indicates the time taken to decelerate from 100% of the rated speed to 0.

P0.69	Data size	16bit	Data format	DEC
	Modbus address	1138, 1139	CANopen address	0x2045, 0x00

P0.70 ¹	Absolute encoder work mode	Setting range	Default	Unit	Applicable mode		
		0-1	0	-	P	S	T

This parameter specifies the running mode of the multiturn absolute encoder. Though the encoder working with the motor is a multiturn absolute encoder, it is still considered as a single-turn encoder by default. If the multiturn absolute function is needed, you need to prepare the spare battery for the encoder and set the work mode as the multiturn absolute mode.

Setting	Meaning
[0]	Single-turn absolute
1	Multiturn absolute

P0.70 ¹	Data size	16bit	Data format	DEC
	Modbus address	1140, 1141	CANopen address	0x2046, 0x00

P0.71*	Clear absolute encoder multiturn	Setting range	Default	Unit	Applicable mode		
		0-1	0	-	P	S	T

This parameter specifies whether to clear the multiturn data for the multiturn absolute encoder. If this function is enabled, the multiturn data is cleared while the single-turn data remains unchanged, but the absolute position in the feedback is cleared.

Note: If you use a multiturn absolute encoder, after machinery installation, you can clear the absolute encoder after detecting the absolute zero position of the mechanic system at first power-on.

P0.71*	Data size	16bit	Data format	DEC
	Modbus address	1142, 1143	CANopen address	0x2047, 0x00

6.1.4 Control mode switching

P0.90	Max. speed limit of control mode switching	Setting range	Default	Unit	Applicable mode		
		1-1000	100	r/min	P	S	T

This parameter specifies the maximum running speed during positioning for switching from the speed or torque mode to the position mode when the hybrid of position and speed or the hybrid of position and torque is used.

P0.90	Data size	16bit	Data format	DEC
	Modbus address	1180, 1181	CANopen address	0x205A, 0x00

P0.91	Positioning reference of control mode switching	Setting range	Default	Unit	Applicable mode		
		-1-(2 ³¹ -1)	-1	pulse	P	S	T

This parameter specifies the motor position R0.14 [Rotor position relative to pulse Z] after the control mode is switched. The switching is made from the speed or torque mode to the position mode when the hybrid of position and speed or the hybrid of position and torque is used.

Note:

- After the control mode switching, the reference point in the received position command is the

setting of this parameter. The unit of this parameter is the encoder pulse unit.

- If this parameter is set to -1 and the control mode needs to switch from speed mode to position mode, switching is executed at the current position, without positioning to the reference point.
- If the mechanical angle corresponding to the setting of P3.50 is no more than 0.5°, the positioning is accurate to ±P3.50. If the angle is greater than 0.5°, the positioning is accurate to the pulse number corresponding to ±0.5°.

P0.91	Data size	32bit	Data format	DEC
	Modbus address	1182, 1183	CANopen address	0x205B, 0x00

P0.92	Position mode exiting method	Setting range	Default	Unit	Applicable mode		
		0-1	0	-	P	S	T

This parameter specifies the method for exiting the position mode when P0.03 [Control mode] is 3 [Position/speed mode] or 4 [Position/torque mode].

Setting	Meaning
[0]	The position mode is switched to another mode after positioning is complete.
1	The position mode is immediately switched to another mode when the control mode switching command is invalid.

P0.92	Data size	32bit	Data format	DEC
	Modbus address	1184, 1185	CANopen address	0x205C, 0x00

P0.93	Exit mode of speed mode switching	Setting range	Default	Unit	Applicable mode		
		0-1	1	-	P	S	T

When P0.03 [Control mode] is 3 [Position/speed mode] or 5 [Speed/torque mode], this parameter specifies the exiting mode of switching from the speed mode to another control mode.

Setting	Meaning
[0]	Decelerate to zero first and then switch from the speed mode to another control mode.
1	Switch to another control mode immediately when the control mode switching command becomes invalid.

P0.93	Data size	32bit	Data format	DEC
	Modbus address	1186, 1187	CANopen address	0x205D, 0x00

6.1.5 Speed display filtering

P0.99	FIR filter level of speed detection	Setting range	Default	Unit	Applicable mode		
		1 - 31	1	-	P	S	T
This parameter specifies the FIR filter level displayed in R0.00 [Motor speed]. The default value of this parameter is 1, indicating no filter. A greater value indicates smoother speed display.							
P0.99	Data size	16bit	Data format	DEC			
	Modbus address	1198, 1199	CANopen address	0x2063, 0x00			

6.2 Autotuning control (group P1)

6.2.1 Inertia identifying (or automatic gain)

P1.00	Tune inertia online	Setting range	Default	Unit	Applicable mode		
		0-1	0	-	P	S	T
This parameter specifies whether to automatically tune inertia online and adjust the gain.							
		Setting	Meaning				
		[0]	Online inertia identifying is invalid.				
		1	Online inertia identifying is valid.				
P1.00	Data size	16bit	Data format	DEC			
	Modbus address	1200, 1201	CANopen address	0x2100, 0x00			

P1.01	Inertia ratio 1	Setting range	Default	Unit	Applicable mode		
		0-10000	250	%	P	S	T
<p>Rotation inertia ratio = Load inertia/Motor rotation inertia x 100%</p> <p>If P1.01 is set correctly, the setting unit of P2.00 and P2.05 is Hz.</p> <p>If P1.01 is greater than the actual value, the speed loop gain unit will increase, and if it is smaller than the actual value, the speed loop gain unit will decrease.</p> <p>If online automatic tuning is valid, the inertia ratio is updated to P1.01 in real time and written to the EEPROM every 30 minutes.</p>							
P1.01	Data size	16bit	Data format	DEC			
	Modbus address	1202, 1203	CANopen address	0x2101, 0x00			

P1.02	Inertia ratio 2	Setting range	Default	Unit	Applicable mode		
		0-10000	250	%	P	S	T

The meaning of P1.02 is similar to that of P1.01.

Note: Automatic online gain adjusting is invalid for this parameter.

P1.02	Data size	16bit	Data format	DEC
	Modbus address	1204, 1205	CANopen address	0x2102, 0x00

P1.03	Mechanical rigidity	Setting range	Default	Unit	Applicable mode		
		0–31	13	-	P	S	T

A greater mechanical rigidity value indicates quicker response and high rigidity performance, but it increases the possibility to cause vibration. In stable working condition, you can set a greater value to obtain quicker response.

Mechanical structure	Rigidity
Large transfer or transmission equipment	0–13
Belt drive mechanism	5–16
Ball screw + belt drive	5–16
Manipulator	15–22
Direct ball screw or rigid body	18–25

P1.03	Data size	16bit	Data format	DEC
	Modbus address	1206, 1207	CANopen address	0x2103, 0x00

P1.04*	Tune inertia offline	Setting range	Default	Unit	Applicable mode		
		0–1	0	-	P	S	T

This parameter is used to obtain the load inertial ratio of the motor rotation inertia. After inertia identifying is enabled, the motor runs six cycles to identify inertia. In each cycle, the motor runs at the mode specified by P1.05 [Inertia identifying mode]. The maximum rotation number of the motor is determined by P1.06 [Max. rotations by inertia identifying], and the ACC command time is determined by P1.07 [ACC time for inertia identifying].

Setting	Meaning
[0]	Disable inertia identifying.
1	Enable inertia identifying.

Note:

- The motor speed is fast during identifying if P1.06 and P1.07 are set to great values.
- If the drive reports the alarm Er25-7 during identifying, see section 9.1 "Servo drive faults and workarounds" to handle it.
- This parameter is invalid when the servo is enabled.

P1.04*	Data size	16bit	Data format	DEC
	Modbus address	1208, 1209	CANopen address	0x2104, 0x00

P1.05	Inertia identifying mode	Setting range	Default	Unit	Applicable mode		
		0–3	0	-	P	S	T

This parameter specifies the work mode for identifying inertia.

Setting	Meaning
[0]	Forward rotation and then reverse rotation
1	Forward rotation
2	Reverse rotation
3	Reverse rotation and then forward rotation

P1.05	Data size	16bit	Data format	DEC
	Modbus address	1210, 1211	CANopen address	0x2105, 0x00

P1.06	Max. rotations by inertia identifying	Setting range	Default	Unit	Applicable mode		
		0.2–20.0	2.0	r	P	S	T

If the inertia identifying mode is valid and specified in position mode, this parameter is used to limit the maximum rotation number of the motor in each cycle.

P1.06	Data size	16bit	Data format	DEC
	Modbus address	1212, 1213	CANopen address	0x2106, 0x00

P1.07	ACC time for inertia identifying	Setting range	Default	Unit	Applicable mode		
		2–1000	200	ms	P	S	T

This parameter specifies the motor ACC time during inertia identifying. If the load inertia is heavy, the ACC time can be set to a greater value, preventing overload alarms.

P1.07	Data size	16bit	Data format	DEC
	Modbus address	1214, 1215	CANopen address	0x2107, 0x00

P1.08	Inertia identifying class	Setting range	Default	Unit	Applicable mode		
		0–3	1	-	P	S	T

This parameter specifies the speed level for inertia identifying.
A large value of this parameter indicates a quick response to the load characteristic changes, resulting in large fluctuation of the presumption value. The presumption result is saved every 30 minutes.

Setting	Function	Meaning
0	No change	Stop the presumption of load characteristics.
[1]	No major change	There is no major change to load characteristics.
2	Slow change	Load characteristics change slowly.
3	Sharp change	Load characteristics change sharply.

P1.08	Data size	16bit	Data format	DEC
	Modbus address	1216, 1217	CANopen address	0x2108, 0x00

6.2.2 Self-adaptive vibration control

P1.19	Resonance detection sensitivity	Setting range	Default	Unit	Applicable mode		
		0.2–100.0	5.0	%	P	S	T

This parameter specifies the sensitivity of the automatic detection on mechanical resonant frequency. A smaller value of this parameter indicates higher sensitivity to the resonance.

P1.19	Data size	16bit	Data format	DEC
	Modbus address	1238, 1239	CANopen address	0x2113, 0x00

P1.20	Resonance detection mode	Setting range	Default	Unit	Applicable mode		
		0–7	0	-	P	S	T

This parameter specifies the working mode of resonance detection, resonant frequency presumed by the self-adaptive notch filter, and action after presumption.

If the function of automatically detecting the mechanical resonant frequency is valid (that is, this parameter is set to 1, 2, or 3), the system automatically collects data to conduct mechanical resonant frequency analysis and saves results to P1.21 and P1.22. You can set the notch filter frequency according to the settings of P1.21 and P1.22 to eliminate the mechanical resonance.

Note: You are recommended to disable the function after the gain adjustment is complete.

Setting	Function	Meaning
[0]	Invalid	All parameters associated with the notch filter remain unchanged.
1	One notch filter valid	The parameters associated with the third notch filter are updated according to the self-adaptive result.
2	Two notch filters valid	The parameters related to the third and fourth notch filters are updated according to the self-adaptive result.
3	Resonant frequency test mode	The mechanical resonant frequency is detected automatically but the parameters associated with notch filters are not set.
4	Clearing notch filter parameters	The parameters associated with the four notch filters are restored to the default values.
5	Notch filter 3 → Notch filter 1	The parameters of the third notch filter to are automatically copied to the first notch filter and then restored to the default values.
6	Notch filter 4 → Notch filter 2	The parameters of the fourth notch filter to are automatically copied to the first notch filter and then restored to the default values.
7	Notch filters 3 and 4 → Notch filters 1 and 2	The parameters of the third and fourth notch filters to are automatically copied to the first and second notch filters and then restored to the default values.

P1.20	Data size	16bit	Data format	DEC
	Modbus address	1240, 1241	CANopen address	0x2114, 0x00

P1.21*	Mechanical resonant frequency	Setting range	Default	Unit	Applicable mode		
	1	0-5000	5000	Hz	P	S	T
P1.22*	Mechanical resonant frequency	Setting range	Default	Unit	Applicable mode		
	2	0-5000	5000	Hz	P	S	T

This group of parameter displays mechanical resonant frequency. When P1.20 is set to 1, indicating mechanical resonance frequency detection is valid, the system detects and displays the frequency at the maximum resonance point.

Note:

- The measurement results are accurate only when the rotation speed reaches 30 r/min at least.

- This function is read only. You can set the notch filter frequency through this group of parameter to eliminate mechanical resonance.
- The value 5000 indicates no resonance point is found.

P1.21	Data size	16bit	Data format	DEC
	Modbus address	1242, 1243	CANopen address	0x2115, 0x00
P1.22	Data size	16bit	Data format	DEC
	Modbus address	1244, 1245	CANopen address	0x2116, 0x00

P1.23	Frequency of notch filter 1	Setting range	Default	Unit	Applicable mode		
		50–5000	5000	Hz	P	S	T

This parameter specifies the frequency of notch filter 1 for suppressing resonance. The notch filter can simulate the mechanical resonant frequency, thus suppressing the resonant frequency.
The value 5000 indicates the notch filter function is invalid.

P1.23	Data size	16bit	Data format	DEC
	Modbus address	1246, 1247	CANopen address	0x2117, 0x00

P1.24	Q factor of notch filter 1	Setting range	Default	Unit	Applicable mode		
		0.50–16.00	1.00	-	P	S	T

This parameter specifies the quality factor (Q factor for short) of notch filter 1.
Q factor of notch filter = Center frequency of notch filter/Bandwidth of notch filter
Generally, the default value is kept.

P1.24	Data size	16bit	Data format	DEC
	Modbus address	1248, 1249	CANopen address	0x2118, 0x00

P1.25	Depth of notch filter 1	Setting range	Default	Unit	Applicable mode		
		0–100	0	%	P	S	T

This parameter specifies the amplitude attenuation rate of notch filter 1.
A large value of this parameter indicates low notch filter depth and small phase lag.

P1.25	Data size	16bit	Data format	DEC
	Modbus address	1250, 1251	CANopen address	0x2119, 0x00

P1.26	Frequency of notch filter 2	Setting range	Default	Unit	Applicable mode		
		50–5000	5000	Hz	P	S	T

P1.27	Q factor of notch filter 2	Setting range	Default	Unit	Applicable mode		

		0.50–16.00	1.00	-	P	S	T
P1.28	Depth of notch filter 2	Setting range	Default	Unit	Applicable mode		
		0–100	0	%	P	S	T
These parameters specify characteristics of notch filter 2, similar to P1.23, P1.24, and P1.25.							
P1.26	Data size	16bit	Data format	DEC			
	Modbus address	1252, 1253	CANopen address	0x211A, 0x00			
P1.27	Data size	16bit	Data format	DEC			
	Modbus address	1254, 1255	CANopen address	0x211B, 0x00			
P1.28	Data size	16bit	Data format	DEC			
	Modbus address	1256, 1257	CANopen address	0x211C, 0x00			

P1.29	Frequency of notch filter 3	Setting range	Default	Unit	Applicable mode		
		50–5000	5000	Hz	P	S	T
P1.30	Q factor of notch filter 3	Setting range	Default	Unit	Applicable mode		
		0.50–16.00	1.00	-	P	S	T
P1.31	Depth of notch filter 3	Setting range	Default	Unit	Applicable mode		
		0–100	0	%	P	S	T
These parameters specify characteristics of notch filter 3, similar to P1.23, P1.24, and P1.25.							
P1.29	Data size	16bit	Data format	DEC			
	Modbus address	1258, 1259	CANopen address	0x211D, 0x00			
P1.30	Data size	16bit	Data format	DEC			
	Modbus address	1260, 1261	CANopen address	0x211E, 0x00			
P1.31	Data size	16bit	Data format	DEC			
	Modbus address	1262, 1263	CANopen address	0x211F, 0x00			

P1.32	Frequency of notch filter 4	Setting range	Default	Unit	Applicable mode		
		50–5000	5000	Hz	P	S	T
P1.33	Q factor of notch filter 4	Setting range	Default	Unit	Applicable mode		
		0.50–16.00	1.00	-	P	S	T
P1.34	Depth of notch filter 4	Setting range	Default	Unit	Applicable mode		

		0–100	0	%	P	S	T
These parameters specify characteristics of notch filter 4, similar to P1.23, P1.24, and P1.25.							
P1.32	Data size	16bit	Data format	DEC			
	Modbus address	1264, 1265	CANopen address	0x2120, 0x00			
P1.33	Data size	16bit	Data format	DEC			
	Modbus address	1266, 1267	CANopen address	0x2121, 0x00			
P1.34	Data size	16bit	Data format	DEC			
	Modbus address	1268, 1269	CANopen address	0x2122, 0x00			

P1.35	Vibration control mode in position command	Setting range	Default	Unit	Applicable mode		
		0–2	0	-	P		

This parameter specifies the filter switching mode for vibration control.

Setting	Meaning
[0]	Vibration control by filter 1 is valid.
1	Filter 1 and filter 2 are switched according to VS-SEL.
2	Automatic

Note: If a digital input terminal is used for selection, one of parameters P3.00–P3.07 must be set to 0x11C or 0x01C (according to VS-SEL).

The relationship with COM- is as follows:

0: Off (The internal optical coupler corresponding to the input is not conducted.)

1: On (The internal optical coupler corresponding to the input is conducted.)

P1.35	Data size	16bit	Data format	DEC			
	Modbus address	1270, 1271	CANopen address	0x2123, 0x00			

P1.36	Vibration control frequency 1	Setting range	Default	Unit	Applicable mode		
		0.0–200.0	0.0	Hz	P		

This parameter specifies the frequency at which the vibration at the load peak is suppressed.

Note: The frequency must range from 1.0 Hz to 200.0 Hz.

P1.36	Data size	16bit	Data format	DEC			
	Modbus address	1272, 1273	CANopen address	0x2124, 0x00			

P1.37	Coefficient of vibration control filter 1	Setting range	Default	Unit	Applicable mode		
		0.00–1.00	1.00	-	P		

This parameter specifies the coefficient of the first vibration control filter.

P1.37	Data size	16bit	Data format	DEC
	Modbus address	1274, 1275	CANopen address	0x2125, 0x00

P1.38	Vibration control frequency 2	Setting range	Default	Unit	Applicable mode		
		0.0–200.0	0.0	Hz	P		
P1.39	Coefficient of vibration control filter 2	Setting range	Default	Unit	Applicable mode		
		0.00–1.00	1.00	-	P		

This group of parameter specifies the characteristics of the second vibration control filter. They are similar to P1.36 and P1.37.

P1.38	Data size	16bit	Data format	DEC
	Modbus address	1276, 1277	CANopen address	0x2126, 0x00
P1.39	Data size	16bit	Data format	DEC
	Modbus address	1278, 1279	CANopen address	0x2127, 0x00

6.3 Motor control (group P2)

6.3.1 Gain settings

P2.00	Speed gain 1	Setting range	Default	Unit	Applicable mode		
		0.0–3276.7	27.0	Hz	P	S	T

The speed loop responsiveness of the servo system is determined by the speed gain. Increasing this parameter improves the speed response, but it increases the possibility to cause vibration and noise.

Note: If the inertia ratio is set correctly, the unit of P2.00 is Hz.

P2.00	Data size	16bit	Data format	DEC
	Modbus address	1400, 1401	CANopen address	0x2200, 0x00

P2.01	Speed integral time constant 1	Setting range	Default	Unit	Applicable mode		
		0.1–1000.0	21.0	ms	P	S	T

This parameter specifies the integral time constant of the speed loop. A smaller value of this parameter indicates quicker response, but it increases the possibility to cause vibration and noise. If this parameter is set to 1000, the integral action is invalid.

P2.01	Data size	16bit	Data format	DEC
	Modbus address	1402, 1403	CANopen address	0x2201, 0x00

P2.02	Position gain 1	Setting range	Default	Unit	Applicable mode		
		0.0–3276.7	48.0	1/s	P		
<p>The position loop responsiveness of the servo system is determined by the position gain. A smaller value of this parameter indicates quicker response, but it increases the possibility to cause vibration and noise.</p>							
P2.02	Data size	16bit	Data format		DEC		
	Modbus address	1404, 1405	CANopen address		0x2202, 0x00		

P2.03	Speed detection filter 1	Setting range	Default	Unit	Applicable mode		
		100–5000	5000	Hz	P	S	T
<p>This parameter specifies the first speed detection filter.</p> <p>Note: The value 5000 indicates no filtering. A smaller value of this parameter indicates lower motor noise and speed fluctuation, but it slows down the responsiveness.</p>							
P2.03	Data size	16bit	Data format		DEC		
	Modbus address	1406, 1407	CANopen address		0x2203, 0x00		
P2.04	Torque filter 1	Setting range	Default	Unit	Applicable mode		
		0.0–25.00	0.84	ms	P	S	T
<p>This parameter specifies the time constant of the torque filter.</p>							
P2.04	Data size	16bit	Data format		DEC		
	Modbus address	1408, 1409	CANopen address		0x2204, 0x00		

P2.05	Speed gain 2	Setting range	Default	Unit	Applicable mode		
		0.0–3276.7	27.0	Hz	P	S	T
P2.06	Speed integral time constant 2	Setting range	Default	Unit	Applicable mode		
		0.1–1000.0	1000.0	ms	P	S	T
P2.07	Position gain 2	Setting range	Default	Unit	Applicable mode		
		0.0–3276.7	57.0	1/s	P		
P2.08	Speed detection filter 2	Setting range	Default	Unit	Applicable mode		
		100–5000	5000	Hz	P	S	T
P2.09	Torque filter 2	Setting range	Default	Unit	Applicable mode		

		0.00–25.00	0.84	ms	P	S	T
<p>There are two groups of parameters respectively for position gain, speed gain, speed integral time constant, speed detection filter, and torque filter.</p> <p>The two groups are similar in function and definition.</p> <p>You can select from gain 1 and gain 2 or switch between them. For details, see the descriptions for P2.20–P2.34.</p>							
P2.05	Data size	16bit	Data format	DEC			
	Modbus address	1410, 1411	CANopen address	0x2205, 0x00			
P2.06	Data size	16bit	Data format	DEC			
	Modbus address	1412, 1413	CANopen address	0x2206, 0x00			
P2.07	Data size	16bit	Data format	DEC			
	Modbus address	1414, 1415	CANopen address	0x2207, 0x00			
P2.08	Data size	16bit	Data format	DEC			
	Modbus address	1416, 1417	CANopen address	0x2208, 0x00			
P2.09	Data size	16bit	Data format	DEC			
	Modbus address	1418, 1419	CANopen address	0x2209, 0x00			

P2.10	Speed feed-forward gain	Setting range	Default	Unit	Applicable mode		
		0.0–100.0	0.0	%	P		
<p>This parameter specifies the speed feed-forward gain. If it is set to 100%, residual pulses are almost zero when the motor runs at a stable speed, but overshooting increases at sudden ACC/DEC.</p>							
P2.10	Data size	16bit	Data format	DEC			
	Modbus address	1420, 1421	CANopen address	0x220A, 0x00			
P2.11	Speed feed-forward filter time	Setting range	Default	Unit	Applicable mode		
		0.00–64.00	0.50	ms	P		
<p>This parameter specifies the speed feed-forward filter time.</p>							
P2.11	Data size	16bit	Data format	DEC			
	Modbus address	1422, 1423	CANopen address	0x220B, 0x00			

P2.12	Torque feed-forward gain	Setting range	Default	Unit	Applicable mode		
		0.0–100.0	0.0	%	P	S	
<p>This parameter specifies the torque feed-forward gain. After the torque is calculated according to the speed control command, the torque multiplied by the setting of this parameter is added to the torque command from speed control.</p> <p>Increasing the torque feed-forward gain can improve response performance in ACC/DEC and</p>							

reduce position deviation.				
P2.12	Data size	16bit	Data format	DEC
	Modbus address	1424, 1425	CANopen address	0x220C, 0x00

P2.13	Torque feed-forward filter time	Setting range	Default	Unit	Applicable mode		
		0.00–64.00	0.00	ms	P	S	

This parameter specifies the torque feed-forward filter time.

P2.13	Data size	16bit	Data format	DEC
	Modbus address	1426, 1427	CANopen address	0x220D, 0x00

P2.14	IPPI coefficient 1	Setting range	Default	Unit	Applicable mode		
		0–1000	100	%	P	S	T

This parameter specifies the first IPPI coefficient.

Note: IP control is applied when it is set to 0, while PI control is applied when it is set to 100.

P2.14	Data size	16bit	Data format	DEC
	Modbus address	1428, 1429	CANopen address	0x220E, 0x00

P2.15	IPPI coefficient 2	Setting range	Default	Unit	Applicable mode		
		0–1000	100	%	P	S	T

This parameter specifies the second IPPI coefficient.

Note: IP control is applied when it is set to 0, while PI control is applied when it is set to 100.

P2.15	Data size	16bit	Data format	DEC
	Modbus address	1430, 1431	CANopen address	0x220F, 0x00

6.3.2 Gain switching

P2.20	Setting of gain 2	Setting range	Default	Unit	Applicable mode		
		0–1	1	-	P	S	T

This parameter specifies the adjustment for gain switching.

Setting	Meaning
0	The first gain is fixed. The speed loop action is switched to the PI or P action based on the gain switching input (that is, the digital input is configured as function gain switching, corresponding to 0x006) or P4.16 [Gain switching command]. Gain switching invalid → PI action Gain switching valid → P action Note: 0x006 is valid when the digital inputs a low electrical level, while 0x106 is valid when the digital inputs a high electrical level.
[1]	Switching between the first gain [P2.00–P2.04] and second gain [P2.05–P2.09] is valid.

P2.20	Data size	16bit	Data format	DEC
	Modbus address	1440, 1441	CANopen address	0x2214, 0x00

P2.22	Switching trigger in position control	Setting range	Default	Unit	Applicable mode
		0–9	0	-	P

This parameter specifies the trigger of gain switching in position control or fully-closed loop control.

Setting	Trigger	Description
[0]	Fixed to gain 1	Gain parameters are fixed to the first gain parameters P2.00–P2.04.
1	Fixed to gain 2	Gain parameters are fixed to the second gain parameters P2.05–P2.09.
2	With gain switching input	The first gain is used if the gain switching input is invalid. The second gain is used if the gain switching input is valid.
3	Torque command too large	When the first gain is used, if the absolute value in the torque command exceeds (level + lag) [0.1%], the first gain is switched to the second gain. When the second gain is used, if the absolute value in the torque command does not reach (level - lag) [0.1%] and this state keeps in the delay time, the first gain is used.
4	Speed command too large	When the first gain is used, if the absolute value in the speed command exceeds (level + lag) [r/min], the first gain is switched to the second gain. When the second gain is used, if the absolute value in the speed command does not reach (level - lag) [r/min] and this state keeps in the delay time, the second gain is switched to the first gain.
5	Position deviation too large	When the first gain is used, if the absolute value of the position deviation exceeds (level + lag) [pulse], the first gain is switched to the second gain.

			When the second gain is used, if the absolute value of the position deviation does not reach (level – lag) [pulse] and this state keeps in the delay time, the second gain is switched to the first gain. Note: The unit of level and lag is the encoder resolution unit in position control and is the grating ruler resolution unit in fully-closed loop control.		
	6	With position command input	When the first gain is used, if the position command is not 0, the first gain is switched to the second gain. When the second gain is used, if the position command is 0 and this state keeps in the delay time, the second gain is switched to the first gain.		
	7	Positioning incomplete	When the first gain is used, if positioning is not complete, the first gain is switched to the second gain. When the second gain is used, if positioning is complete and this state keeps in the delay time, the second gain is switched to the first gain.		
	8	Actual speed too high	When the first gain is used, if the absolute value of the actual speed exceeds (level + lag) [r/min], the first gain is switched to the second gain. When the second gain is used, if the absolute value of the actual speed does not reach (level – lag) [r/min] and this state keeps in the delay time, the second gain is switched to the first gain.		
	9	Position command + actual speed	When the first gain is used, if the position command is not 0, the first gain is switched to the second gain. When the second gain is used, if the position command is 0, this state keeps in the delay time, and the absolute value of the actual speed does not reach (level – lag) [r/min], the second gain is switched to the first gain.		
P2.22	Data size		16bit	Data format	DEC
	Modbus address		1444, 1445	CANopen address	0x2216, 0x00

P2.23	Switching delay in position control	Setting range	Default	Unit	Applicable mode		
		0–10000	0	ms	P		
In position control, if P2.22 is in the range of 3–9, the first gain is switched back from the second gain. This parameter specifies the time from the triggering to the actual switching.							
P2.23	Data size		16bit	Data format	DEC		
	Modbus address		1446, 1447	CANopen address	0x2217, 0x00		

P2.24	Switching level in position control	Setting range	Default	Unit	Applicable mode		
		0–20000	0	Mode based	P		
<p>In position control, if P2.22 is in the range of 3–5, or set to 8 or 9, the trigger of gain switching must be set. The unit varies with the switching mode and associated settings.</p> <p>Note: The level must be equal to the lag at least.</p>							
P2.24	Data size	16bit	Data format		DEC		
	Modbus address	1448, 1449	CANopen address		0x2218, 0x00		
P2.25	Switching lag in position control	Setting range	Default	Unit	Applicable mode		
		0–20000	0	Mode based	P		
<p>In position control, if P2.22 is in the range of 3–5, or set to 8 or 9, the trigger of gain switching must be set to determine the lag. The unit varies with the switching mode and associated settings.</p> <p>Note: If the level is set to be less than the lag, the setting is changed to the level being equal to the lag during the actual use.</p>							
P2.25	Data size	16bit	Data format		DEC		
	Modbus address	1450, 1451	CANopen address		0x2219, 0x00		
P2.26	Position gain switching time	Setting range	Default	Unit	Applicable mode		
		0–10000	0	ms	P		
<p>In position control, if the difference between P2.00 and P2.04 is great, you can set this parameter to control the torque change and vibration caused by the switching from the small gain to the large gain at the current position. This parameter is invalid when the position gain is switched from a large value to a small one, and the switching takes effect immediately.</p>							
P2.26	Data size	16bit	Data format		DEC		
	Modbus address	1452, 1453	CANopen address		0x221A, 0x00		
P2.27	Switching trigger in speed control	Setting range	Default	Unit	Applicable mode		
		0–5	0	-		S	

This parameter specifies the trigger of gain switching in speed control.

Setting	Trigger	Description
[0]	Fixed to gain 1	Gain parameters are fixed to the first gain parameters P2.00–P2.04.
1	Fixed to gain 2	Gain parameters are fixed to the second gain parameters P2.05, P2.06, P2.08, and P2.09.
2	With gain switching input	The first gain is used if the gain switching input is invalid. The second gain is used if the gain switching input is valid.
3	Torque command	When the first gain is used, if the absolute value in the torque command exceeds (level + lag) [0.1%], the first gain is switched to the second gain. When the second gain is used, if the absolute value in the torque command does not reach (level – lag) [0.1%] and this state keeps in the delay time, the second gain is switched to the first gain.
4	Speed command variable	When the first gain is used, if the absolute value in the speed command exceeds (level + lag) [10 r/min/s], the first gain is switched to the second gain. When the second gain is used, if the absolute value in the speed command does not reach (level – lag) [10 r/min/s] and this state keeps in the delay time, the second gain is switched to the first gain.
5	Speed command	When the first gain is used, if the absolute value in the speed command exceeds (level + lag) [r/min], the first gain is switched to the second gain. When the second gain is used, if the absolute value in the speed command does not reach (level – lag) [r/min] and this state keeps in the delay time, the second gain is switched to the first gain.

Note: This parameter is invalid for position gain, meaning the actual position gain is always the first gain.

P2.27	Data size	16bit	Data format	DEC
	Modbus address	1454, 1455	CANopen address	0x221B, 0x00

P2.28	Switching delay in speed control	Setting range	Default	Unit	Applicable mode	
		0–10000	0	ms	S	

In speed control, if P2.27 is in the range of 3–5, the first gain is switched back from the second gain. This parameter specifies the time from the triggering to the actual switching.

P2.28	Data size	16bit	Data format	DEC
	Modbus address	1456, 1457	CANopen address	0x221C, 0x00

P2.29	Switching level in speed control	Setting range	Default	Unit	Applicable mode
-------	----------------------------------	----------------------	----------------	-------------	------------------------

		0–20000	0	Mode based		S	
<p>In speed control, if P2.27 is in the range of 3–5, the trigger of gain switching must be set. The unit varies with the switching mode and associated settings.</p> <p>Note: The level must be equal to the lag at least.</p>							
P2.29	Data size	16bit	Data format		DEC		
	Modbus address	1458, 1459	CANopen address		0x221D, 0x00		

P2.30	Switching lag in speed control	Setting range	Default	Unit	Applicable mode		
		0–20000	0	Mode based		S	
<p>In speed control, if P2.27 is in the range of 3–5, the trigger of gain switching must be set to determine the lag. The unit varies with the switching mode and associated settings.</p> <p>Note: If the level is set to be less than the lag, the setting is changed to the level being equal to the lag during the actual use.</p>							
P2.30	Data size	16bit	Data format		DEC		
	Modbus address	1460, 1461	CANopen address		0x221E, 0x00		

P2.31	Switching trigger in torque control	Setting range	Default	Unit	Applicable mode		
		0–3	0	-			T

This parameter specifies the trigger of gain switching in torque control.

Setting	Trigger	Description
[0]	Fixed to gain 1	Gain parameters are fixed to the first gain parameters P2.00–P2.04.
1	Fixed to gain 2	Gain parameters are fixed to the second gain parameters P2.05, P2.06, P2.08, and P2.09.
2	With gain switching input	The first gain is used if the gain switching input is invalid. The second gain is used if the gain switching input is valid.
3	Torque command	When the first gain is used, if the absolute value in the torque command exceeds (level + lag) [0.1%], the first gain is switched to the second gain. When the second gain is used, if the absolute value in the torque command does not reach (level – lag) [0.1%] and this state keeps in the delay time, the second gain is switched to the first gain.

Note: This parameter is invalid for position gain, and in this case, the actual position gain is the first gain always.

P2.31	Data size	16bit	Data format		DEC		
	Modbus address	1462, 1463	CANopen address		0x221F, 0x00		

P2.32	Switching delay in torque control	Setting range	Default	Unit	Applicable mode		
		0–10000	0	ms			T
In torque control, if P2.31 is set to 3, the first gain is switched back from the second gain. This parameter specifies the time from the triggering to the actual switching.							
P2.32	Data size	16bit	Data format		DEC		
	Modbus address	1464, 1465	CANopen address		0x2220, 0x00		

P2.33	Switching level in torque control	Setting range	Default	Unit	Applicable mode		
		0–20000	0	Mode based			T
In torque control, if P2.31 is set to 3, the trigger of gain switching must be set. The unit varies with the switching mode and associated settings.							
Note: The level must be equal to the lag at least.							
P2.33	Data size	16bit	Data format		DEC		
	Modbus address	1466, 1467	CANopen address		0x2221, 0x00		

P2.34	Switching lag in torque control	Setting range	Default	Unit	Applicable mode		
		0–20000	0	Mode based			T
In torque control, if P2.31 is set to 3, the trigger of gain switching must be set to determine the lag. The unit varies with the switching mode and associated settings.							
Note: If the level is set to be less than the lag, the setting is changed to the level being equal to the lag during the actual use.							
P2.34	Data size	16bit	Data format		DEC		
	Modbus address	1468, 1469	CANopen address		0x2222, 0x00		

6.3.3 Special motor control

P2.41 ²	Disturbance observer	Setting range	Default	Unit	Applicable mode		
		0–2	0	-	P	S	T
This parameter specifies whether the disturbance observer is valid.							
		Setting	Meaning				
		[0]	Invalid				
		1	Disturbance observation				
		2	Disturbance compensation				
P2.41 ²	Data size	16bit	Data format		DEC		
	Modbus address	1482, 1483	CANopen address		0x2229, 0x00		

P2.42	Disturbance observer compensation gain	Setting range	Default	Unit	Applicable mode		
		0–100	0	%	P	S	
<p>This parameter specifies the compensation gain for disturbance torque. Increasing the gain may improve the effect of suppressing disturbance impact but the noise may increase. This parameter needs to be used with P2.43 to find the best setting point. After setting P2.43, increase the setting of P2.42.</p>							
P2.42	Data size	16bit	Data format		DEC		
	Modbus address	1484, 1485	CANopen address		0x222A, 0x00		

P2.43	Disturbance observer cut-off frequency	Setting range	Default	Unit	Applicable mode		
		0–3000	200	Hz	P	S	
<p>This parameter specifies the cut-off frequency of the disturbance observer. Decreasing the setting of this parameter may decrease noise, while increasing the setting may decrease the disturbance torque compensation delay. This parameter needs to be used with P2.42.</p>							
P2.43	Data size	16bit	Data format		DEC		
	Modbus address	1486, 1487	CANopen address		0x222B, 0x00		

P2.44	Torque command offset	Setting range	Default	Unit	Applicable mode		
		-500.0–500.0	0.0	%	P	S	T
<p>This parameter specifies the changeable load compensation which is added to the torque command. It is usually be used in the vertical shaft application scenario, which excludes the torque control mode.</p>							
P2.44	Data size	16bit	Data format		DEC		
	Modbus address	1488, 1489	CANopen address		0x222C, 0x00		

P2.50 ²	Fully-closed loop vibration suppressor	Setting range	Default	Unit	Applicable mode										
		0–2	0	-											
<p>This parameter specifies whether the speed observer is valid.</p> <table border="1" style="width: 100%; border-collapse: collapse;"> <thead> <tr> <th style="width: 15%;">Setting</th> <th>Meaning</th> </tr> </thead> <tbody> <tr> <td>[0]</td> <td>Invalid</td> </tr> <tr> <td>1</td> <td>Disturbance observation</td> </tr> <tr> <td>2</td> <td>Disturbance compensation</td> </tr> </tbody> </table>								Setting	Meaning	[0]	Invalid	1	Disturbance observation	2	Disturbance compensation
Setting	Meaning														
[0]	Invalid														
1	Disturbance observation														
2	Disturbance compensation														
P2.50 ²	Data size	16bit	Data format		DEC										
	Modbus address	1500, 1501	CANopen address		0x2232, 0x00										

P2.51	Fully-closed loop vibration suppressor cut-off frequency	Setting range	Default	Unit	Applicable mode		
		1.0–500.0	100.0	Hz			

This parameter specifies the cut-off frequency of the closed-loop vibration suppressor.

P2.51	Data size	16bit	Data format		DEC		
	Modbus address	1502, 1503	CANopen address		0x2233, 0x00		

P2.52	Fully-closed loop vibration suppressor compensation gain	Setting range	Default	Unit	Applicable mode		
		0–1000	0	%			

This parameter specifies the compensation gain of the fully-closed loop vibration suppressor.

P2.52	Data size	16bit	Data format		DEC		
	Modbus address	1504, 1505	CANopen address		0x2234, 0x00		

P2.53	Medium frequency vibration control switch	Setting range	Default	Unit	Applicable mode		
		0–1	0	-	P	S	T

This parameter specifies whether the medium frequency vibration control is valid.

Setting	Meaning
[0]	Invalid
1	Valid

P2.53	Data size	16bit	Data format		DEC		
	Modbus address	1506, 1507	CANopen address		0x2235, 0x00		

P2.54	Vibration control frequency	Setting range	Default	Unit	Applicable mode		
		1–2000	100	Hz	P	S	T

This parameter specifies the frequency for medium frequency vibration control.

P2.54	Data size	16bit	Data format		DEC		
	Modbus address	1508, 1509	CANopen address		0x2236, 0x00		

P2.55	Inertia adjustment	Setting range	Default	Unit	Applicable mode		
		1–1000	100	%	P	S	T

This parameter specifies the inertia adjustment for medium frequency vibration control.

The default value 100% indicates that no inertia adjustment is performed for medium frequency vibration control.

P2.55	Data size	16bit	Data format	DEC		
	Modbus address	1510, 1511	CANopen address	0x2237, 0x00		
P2.56	Attenuation gain	Setting range	Default	Unit	Applicable mode	
		0–1000	0	%	P	S
<p>This parameter specifies the attenuation gain for medium frequency vibration control.</p> <p>The default value 0 indicates that there is no attenuation effect on medium frequency vibration control. You can set this parameter based on the actual commissioning result. Ideally, if this parameter is set to 100%, the medium frequency vibration is controlled completely.</p>						
P2.56	Data size	16bit	Data format	DEC		
	Modbus address	1512, 1513	CANopen address	0x2238, 0x00		

P2.57	Adjustment on filter time 1	Setting range	Default	Unit	Applicable mode	
		-10–10	0	0.01ms	P	S
<p>This parameter specifies the adjustment on filter time 1 for medium frequency vibration control. Filter time 1 for medium frequency vibration control is automatically calculated based on P2.54.</p>						
P2.57	Data size	16bit	Data format	DEC		
	Modbus address	1514, 1515	CANopen address	0x2239, 0x00		

P2.58	Adjustment on filter time 2	Setting range	Default	Unit	Applicable mode	
		-10–10	0	0.01ms	P	S
<p>This parameter specifies the adjustment on filter time 2 for medium frequency vibration control. Filter time 2 for medium frequency vibration control is automatically calculated based on P2.54.</p>						
P2.58	Data size	16bit	Data format	DEC		
	Modbus address	1516, 1517	CANopen address	0x223A, 0x00		

P2.60 ²	Speed observer	Setting range	Default	Unit	Applicable mode									
		0–2	0	-	P	S	T							
<p>This parameter specifies whether the speed observer is valid.</p> <table border="1" style="width: 100%; border-collapse: collapse;"> <thead> <tr> <th style="width: 15%;">Setting</th> <th>Meaning</th> </tr> </thead> <tbody> <tr> <td>[0]</td> <td>Invalid</td> </tr> <tr> <td>1</td> <td>Speed observation</td> </tr> <tr> <td>2</td> <td>Speed compensation</td> </tr> </tbody> </table>							Setting	Meaning	[0]	Invalid	1	Speed observation	2	Speed compensation
Setting	Meaning													
[0]	Invalid													
1	Speed observation													
2	Speed compensation													
P2.60 ²	Data size	16bit	Data format	DEC										
	Modbus address	1520, 1521	CANopen address	0x223C, 0x00										

P2.61	Speed observer gain	Setting range	Default	Unit	Applicable mode		
		1-1000	100	Hz	P	S	T

This parameter specifies the speed observer gain. Increasing this parameter improves the response to the actual speed, but it may increase the possibility to cause vibration and noise.

P2.61	Data size	16bit	Data format	DEC			
	Modbus address	1522, 1523	CANopen address	0x223D, 0x00			

P2.70	Friction compensation cut-off speed	Setting range	Default	Unit	Applicable mode		
		0-1000	20	r/min	P	S	

This parameter specifies the cut-off speed of friction compensation.

P2.70	Data size	16bit	Data format	DEC			
	Modbus address	1540, 1541	CANopen address	0x2246, 0x00			

P2.71	CCW torque coefficient of friction compensation	Setting range	Default	Unit	Applicable mode		
		0.0-100.0	0.0	%/(10r/min)	P	S	

This parameter specifies the friction compensation value added to the torque command when a CCW position command or speed command is received.

P2.71	Data size	16bit	Data format	DEC			
	Modbus address	1542, 1543	CANopen address	0x2247, 0x00			

P2.72	CW torque coefficient of friction compensation	Setting range	Default	Unit	Applicable mode		
		-100.0-0.0	0.0	%/(10r/min)	P	S	

This parameter specifies the friction compensation value added to the torque command when a CW position command or speed command is received.

P2.72	Data size	16bit	Data format	DEC			
	Modbus address	1544, 1545	CANopen address	0x2248, 0x00			

P2.73	Friction compensation	Setting range	Default	Unit	Applicable mode		
		0-1	0	-	P	S	

This parameter specifies whether friction compensation is valid.

Setting	Meaning
[0]	Invalid
1	Valid

P2.73	Data size	16bit	Data format	DEC
	Modbus address	1546, 1547	CANopen address	0x2249, 0x00

P2.85	Torque feed-forward	Setting range	Default	Unit	Applicable mode		
		0–1	0	-	P	S	T

This parameter specifies torque feed-forward.

Setting	Meaning
[0]	Speed command
1	Position command

P2.85	Data size	16bit	Data format	DEC
	Modbus address	1570, 1571	CANopen address	0x2255, 0x00

P2.91	No-deviation control gain	Setting range	Default	Unit	Applicable mode		
		1.0–2000.0	50.0	1/s	P		

This parameter specifies no-deviation control gain. A greater gain indicates a smaller position tracking error, but noise will be introduced.

Note: When using this function, set P2.85 1, indicating position command feedforward.

P2.91	Data size	16bit	Data format	DEC
	Modbus address	1582, 1583	CANopen address	0x225B, 0x00

P2.92	No-deviation control attenuation coefficient	Setting range	Default	Unit	Applicable mode		
		50.0–200.0	100.0	%	P		

This parameter specifies no-deviation control attenuation coefficient. In most cases, keep the default value.

P2.92	Data size	16bit	Data format	DEC
	Modbus address	1584, 1585	CANopen address	0x225C, 0x00

6.4 I/O management (group P3)

6.4.1 Digital input/output

P3.00 ¹	Input of digital 1	Setting range	Default	Unit	Applicable mode		
		0x000–0x136	0x003	-	P	S	T

This parameter specifies the input of digital 1. It is in the hexadecimal format.

In the expression of 0x*—, * indicates the valid mode, the value 0 indicates the input is valid when the optical coupler is conductive, while the value 1 indicates the input is valid when the optical coupler is not conductive.

In the expression of 0x—**, ** indicate the function settings. The detailed function settings are listed in the following.

Function	Symbol	Setting		Applicable mode		
		Valid when optical coupler not conducted	Valid when optical coupler conducted			
Invalid	—	0x100	0x000	P	S	T
Disabling forward drive	POT	0x101	0x001	P	S	T
Disabling reverse drive	NOT	0x102	0x002	P	S	T
Enabling servo	SON	0x103	0x003	P	S	T
Clearing alarms	CLA	0x104	0x004	P	S	T
Switching control modes	MCH	x105	0x005	P	S	T
Switching gains	PLC	0x106	0x006	P	S	T
Clearing residual pulses	RPC	0x107	0x007	P		
Inhibiting command pulses	LL	0x108	0x008	P		
Switching torque limits	TLC	0x109	0x009	P	S	
Internal-speed command 1	SPD1	0x10A	0x00A		S	T
Internal-speed command 2	SPD2	0x10B	0x00B		S	T
Internal-speed command 3	SPD3	0x10C	0x00C		S	
Zero speed clamp	ZRS	0x10D	0x00D		S	T
Speed command sign	S-SIGN	0x10E	0x00E		S	
Torque command sign	T-SIGN	0x10F	0x00F			T
Internal position command 1	OS1	0x110	0x010	P		
Internal position command 2	OS2	0x111	0x011	P		
Internal position command 3	POS3	0x112	0x012	P		
Internal position command 4	POS4	0x113	0x013	P		
External fault	EXT	0x114	0x014	P	S	T
Switching inertia ratios	JC	0x115	0x015	P	S	T
Emergency stop	EMG	x116	0x016	P	S	T

Home switch input	HOME	0x117	0x017	P		
Homing trigger	HTRG	0x118	0x018	P		
Numerator selection 1 for electronic gear ratio	SC1	0x119	0x019	P		
Numerator selection 2 for electronic gear ratio	SC2	0x11A	0x01A	P		
PTP control trigger	TRIG	0x11B	0x01B	P		
Vibration control switching input	VS-SEL	0x11C	0x01C	P		
Quick stop	Q-STOP	0x11D	0x01D	P	S	T
PTP control stop	PTP-ST	0x11E	x01E	P		
Clearing absolute position	PCLR	0x11F	0x01F	P		
Internal position command 5	POS5	0x120	0x020	P		
Internal position command 6	P S6	0x121	0x021	P		
Internal position command 7	POS7	0x122	0x022	P		
Forward jogging	FJOG	0x123	0x023	P		
Reverse jogging	RJOG	0x124	0x024	P		
Switching high/low jogging speed	JOGC	0x125	0x025	P		
Reserved	/	0x126	0x026			
Reserved	/	0x127	x027			
Reserved	/	0x128	0x028			
Reserved	/	0x129	0x029			
Reserved	/	0x12A	0x02			
Reserved	/	0x12B	0x02B			
Enabling terminal jogging	DJOG	0x12C	0x02C	P		
Gantry synchronization cancellation input	GIN	0x12D	0x02D	P		
Master gantry synchronization alignment sensor	GSM	0x12E	0x02E	P		
Slave gantry synchronization alignment sensor	GSS	0x12F	0x02F	P		
Dynamic brake relay feedback	DBS	0x130	0x030	P		T
Auto/manually switching turrets	DAT	0x131	0x031	P		
Turret forward jogging	DFJ	0x132	0x032	P		
Turret reverse jogging	DR	0x133	0x033	P		

Magnetic pole check	PDET	0x134	0x034	P	S	T
Suspending PTP terminal	PSTOP	0x135	0x035	P		
Suspending EzJOG terminal	ESTOP	0x136	0x036	P		

Note: The default values indicate the functions applied in position mode.

P3.00 ¹	Data size	16bit	Data format	HEX
	Modbus address	1600, 1601	CANopen address	0x2300, 0x00

P3.01 ¹	Input of digital 2	Setting range	Default	Unit	Applicable mode		
		0x000–0x136	0x00D	-	P	S	T
P3.02 ¹	Input of digital 3	Setting range	Default	Unit	Applicable mode		
		0x000–0x136	0x004	-	P	S	T
P3.03 ¹	Input of digital 4	Setting range	Default	Unit	Applicable mode		
		0x000–0x136	0x016	-	P	S	T
P3.04 ¹	Input of digital 5	Setting range	Default	Unit	Applicable mode		
		0x000–0x136	0x019	-	P	S	T
P3.05 ¹	Input of digital 6	Setting range	Default	Unit	Applicable mode		
		0x000–0x136	0x01A	-	P	S	T
P3.06 ¹	Input of digital 7	Setting range	Default	Unit	Applicable mode		
		0x000–0x136	0x001	-	P	S	T
P3.07 ¹	Input of digital 8	Setting range	Default	Unit	Applicable mode		
		0x000–0x136	0x002	-	P	S	T
P3.08 ¹	Input of digital 9	Setting range	Default	Unit	Applicable mode		
		0x000–0x136	0x007	-	P	S	T
P3.09 ¹	Input of digital 10	Setting range	Default	Unit	Applicable mode		
		0x000–0x136	0x008	-	P	S	T

This group of parameter specifies input functions for digital 2 to 10. These parameters are in the hexadecimal format.

For P3.01–P3.0x, the value of x varies with the product model. For details, see the definition of CN1.

The setting method is similar to that for P3.00.

Note: The default values indicate the functions applied in position mode.

P3.01 ¹	Data size	16bit	Data format	HEX
	Modbus address	1602, 1603	CANopen address	0x2301, 0x00
P3.02 ¹	Data size	16bit	Data format	HEX
	Modbus address	1604, 1605	CANopen address	0x2302, 0x00
P3.03 ¹	Data size	16bit	Data format	HEX
	Modbus address	1606, 1607	CANopen address	0x2303, 0x00
P3.04 ¹	Data size	16bit	Data format	HEX
	Modbus address	1608, 1609	CANopen address	0x2304, 0x00
P3.05 ¹	Data size	16bit	Data format	HEX
	Modbus address	1610, 1611	CANopen address	0x2305, 0x00
P3.06 ¹	Data size	16bit	Data format	HEX
	Modbus address	1612, 1613	CANopen address	0x2306, 0x00
P3.07 ¹	Data size	16bit	Data format	HEX
	Modbus address	1614, 1615	CANopen address	0x2307, 0x00
P3.08 ¹	Data size	16bit	Data format	HEX
	Modbus address	1616, 1617	CANopen address	0x2308, 0x00
P3.09 ¹	Data size	16bit	Data format	HEX
	Modbus address	1618, 1619	CANopen address	0x2309, 0x00

P3.10 ¹	Output of digital 1	Setting range	Default	Unit	Applicable mode		
		0x000–0x11F	0x001	-	P	S	T

This parameter specifies the output of digital 1. It is in the hexadecimal format.

In the expression of 0x*—, * indicates the valid mode, the value 0 indicates the input is valid when the optical coupler is conductive, while the value 1 indicates the input is valid when the optical coupler is not conductive.

In the expression of 0x—**, ** indicate function settings. The detailed function settings are listed in the following.

Signal	Symbol	Setting		Applicable mode		
		Valid when optical coupler not conducted	Valid when optical coupler conducted			
Invalid	—	0x100	0x000	P	S	T
Servo readiness output	RDY	0x101	0x001	P	S	T
Servo running output	RUN	0x102	0x002	P	S	T
Fault output	ALM	0x103	0x003	P	S	T

Reserved	/	0x104	0x004			
Electromagnetic brake release	BRK	0x105	0x005	P	S	T
Position command existence	PCMD	0x106	0x006	P		
Positioning completion	PLR	0x107	0x007	P		
Control mode switching status	MCHS	0x108	0x008	P	S	T
Speed consistency	COIN	0x109	0x009	P	S	T
Speed reaching	SR	0x10A	0x00A	P	S	T
Speed being limited	SL	0x10B	0x00B			T
Speed command existence	SCMD	0x10C	0x00C		S	
Zero-speed output	ZSO	0x10D	0x00D	P	S	T
Torque being limited	LM	0x10E	0x00E	P	S	T
Homing completion	HEND	0x10F	0x00F	P		
Torque reaching	TRCH	0x110	0x010			T
Reserved	/	0x111	0x011			
Reserved	/	0x112	0x012			
Reserved	/	0x113	0x013			
Reserved	/	0x114	0x014			
Reserved	/	0x115	0x015			
PTP reaching	PTPF	0x116	0x016	P		
PTP output 1	PTPO1	0x117	0x017	P		
PTP output 2	PTPO2	0x118	0x018	P		
PTP output 3	PTPO3	0x119	0x019	P		
PTP output 4	PTPO4	0x11A	0x01A	P		
PTP output 5	PTPO5	0x11B	0x01B	P		
PTP output 6	PTPO6	0x11C	0x01C	P		
PTP output 7	PTPO7	0x11D	0x01D	P		
Gantry synchronization cancellation output	GSC	0x11E	0x01E	P		
Dynamic brake relay control	DBRC	0x11F	0x01F	P	S	T

Note: The default values indicate the functions applied in position mode.

P3.10 ¹	Data size	16bit	Data format	HEX
	Modbus address	1620, 1621	CANopen address	0x230A, 0x00

P3.11 ¹	Output of digital 2	Setting range	Default	Unit	Applicable mode		
		0x000–0x11F	0x003	-	P	S	T
P3.12 ¹	Output of digital 3	Setting range	Default	Unit	Applicable mode		
		0x000–0x11F	0x007	-	P	S	T
P3.13 ¹	Output of digital 4	Setting range	Default	Unit	Applicable mode		
		0x000–0x11F	0x00D	-	P	S	T

This group of parameter specifies output functions for digitals 2 to 6. These parameters are in the hexadecimal format.

The setting method is similar to that for P3.10.

Note: The default values indicate the functions applied in position mode.

P3.11 ¹	Data size	16bit	Data format	HEX
	Modbus address	1622, 1623	CANopen address	0x230B, 0x00
P3.12 ¹	Data size	16bit	Data format	HEX
	Modbus address	1624, 1625	CANopen address	0x230C, 0x00
P3.13 ¹	Data size	16bit	Data format	HEX
	Modbus address	1626, 1627	CANopen address	0x230D, 0x00

P3.16	DI-based encoder capturing	Setting range	Default	Unit	Applicable mode		
		0–778	0	-	P	S	T

This parameter specifies the function for capturing the encoder position through the jump edge of the DI port in real time. You can check the obtained result through R1.16.

Data bit	Description	Remarks
bit0–3	Bits 0–3 = 0x1–0Xa, corresponding to capturing DI1–DI10	Others are invalid.
bit8–9	Bit 8 = 1 and bit 9 = 0: Capture only through the falling edge of the DI port. Bit 8 = 0 and bit 9 = 0: Capture only through the rising edge of the DI port. Bit 8 = 1 and bit 9 = 1: Capture through both the rising edge and falling edge of the DI port.	

P3.16	Data size	16bit	Data format	DEC
	Modbus address	1632, 1633	CANopen address	0x2310, 0x00

6.4.2 Analog input/output

P3.20	Offset of AI 1	Setting range	Default	Unit	Applicable mode		
		-10.000–10.000	0.000	V	P	S	T

This parameter is used to adjust analog input 1 to improve the effective accuracy of the AI. Due to reasons such as the zero drift of analog input devices or induced voltage in the ambient environment, the actual analog input value may deviate from the expected value, and such deviation can be eliminated by setting the offset of AI.

See the following figure for the analog input offset voltage:

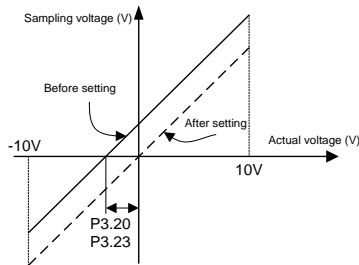

Example: After the command terminal of drive analog input 1 is connected to the analog reference signal, even if the analog reference signal is 0, the voltage of analog input 1, (specified by R1.05), is displayed as 0.02V on the panel, P3.20 must be set to 0.02 at this time. The drive automatically subtracts 0.02V from the analog input value received. If the voltage of analog input 2, displayed by the panel, is -0.02V, P3.20 must be set to -0.02. The drive automatically adds 0.02V to the analog input value received, and the value displayed on the panel changes as well.

P3.20	Data size	32bit	Data format	DEC
	Modbus address	1640, 1641	CANopen address	0x2314, 0x00

P3.21	Filter of AI 1	Setting range	Default	Unit	Applicable mode		
		0.0–1000.0	1.0	ms	P	S	T

This parameter specifies the time constant of the first-order low-pass filter corresponding to analog input 1. Setting this parameter can smooth the command change when the analog input changes sharply.

See the following figure:

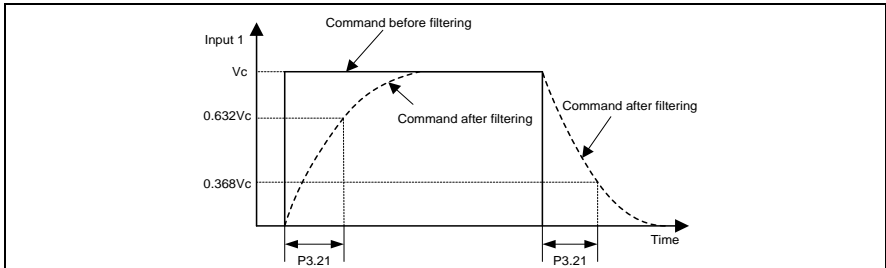

P3.21	Data size	16bit	Data format	DEC
	Modbus address	1642, 1643	CANopen address	0x2315, 0x00

P3.22	OV protection threshold of AI 1	Setting range	Default	Unit	Applicable mode		
		0.000–10.000	0.000	V	P	S	T

This parameter specifies the overvoltage (OV) protection threshold of analog input 1. If the absolute value of R1.05 exceeds the setting of this parameter, the system reports a fault.

Note:

- The default value 0 indicates OV protection is not used.
- The setting of this parameter cannot be greater than 10V. Otherwise, the drive may be damaged.

P3.22	Data size	32bit	Data format	DEC
	Modbus address	1644, 1645	CANopen address	0x2316, 0x00

P3.23	Offset of AI 2	Setting range	Default	Unit	Applicable mode		
		-10.000–10.000	0.000	V	P	S	T

This parameter is used to adjust the analog input 2 to improve the effective accuracy of the AI. The setting method of this parameter is similar to that of P3.20.

P3.23	Data size	32bit	Data format	DEC
	Modbus address	1646, 1647	CANopen address	0x2317, 0x00

P3.24	Filter of AI 2	Setting range	Default	Unit	Applicable mode		
		0.0–1000.0	1.0	ms	P	S	T

This parameter specifies the time constant of the first-order low-pass filter corresponding to analog input 2. Setting this parameter can smooth the command change when the analog input changes sharply.

See the following figure:

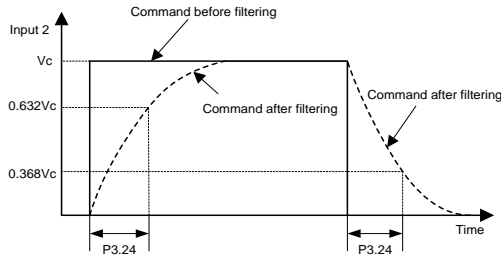

P3.24	Data size	16bit	Data format	DEC
	Modbus address	1648, 1649	CANopen address	0x2318, 0x00

P3.25	OV protection threshold of AI 2	Setting range	Default	Unit	Applicable mode		
		0.000–10.000	0.000	V	P	S	T

This parameter specifies the OV protection value of analog input 2.

Note:

- The default value 0 indicates OV protection is not used.
- The setting of this parameter cannot be greater than 10V. Otherwise, the drive may be damaged.

P3.25	Data size	32bit	Data format	DEC
	Modbus address	1650, 1651	CANopen address	0x2319, 0x00

P3.26 ¹	Function of AI 1	Setting range	Default	Unit	Applicable mode		
		0–7	0	-	P	S	T
P3.27 ¹	Function of AI 2	Setting range	Default	Unit	Applicable mode		
		0–7	3	-	P	S	T

This group of parameter specifies functions for analog inputs.

Setting	Meaning	Unit
[0]	Invalid	-
1	Speed limit	r/min
2	Forward torque limit	0.1%
3	Speed command	r/min
4	Torque command	0.1%
5	Speed compensation	r/min
6	Torque compensation	0.1%
7	Reverse torque limit	0.1%

P3.26 ¹	Data size	16bit	Data format	DEC
	Modbus address	1652, 1653	CANopen address	0x231A, 0x00
P3.27 ¹	Data size	16bit	Data format	DEC
	Modbus address	1654, 1655	CANopen address	0x231B, 0x00

P3.28	Analog speed compensation gain	Setting range	Default	Unit	Applicable mode		
		0.0–100.0	0.0	%	P		

This parameter specifies the analog speed compensation gain.

P3.28	Data size	16bit	Data format	DEC
	Modbus address	1656, 1657	CANopen address	0x231C, 0x00

P3.29	Analog torque compensation gain	Setting range	Default	Unit	Applicable mode		
		0.0–100.0	0.0	%	P	S	T

This parameter specifies the analog torque compensation gain.

P3.29	Data size	16bit	Data format	DEC
	Modbus address	1658, 1659	CANopen address	0x231D, 0x00

P3.30 ¹	Function of AO 1	Setting range	Default	Unit	Applicable mode		
		0–19	0	-	P	S	T
P3.32 ¹	Function of AO 2	Setting range	Default	Unit	Applicable mode		
		0–19	0	-	P	S	T

This group of parameter specifies monitoring parameters for analog output.

Setting	Meaning	Unit
[0]	Invalid	-
1	Motor speed	r/min
2	Speed in a position command	r/min
3	Internal position command	pulse (encoder unit)
4	Speed command	r/min
5	Torque command	0.1%
6	Torque feedback	0.1%
7	Command position deviation	reference unit
8	Encoder position deviation	pulse (encoder unit)
9	Fully-closed loop position deviation	pulse (grating ruler unit)
10	Hybrid control deviation	reference unit
11	Main circuit DC voltage	V
12	Forward torque limit	0.1%
13	Reverse torque limit	0.1%
14	Speed limit	r/min
15	Inertia ratio	%
16	Analog input 1*	V
17	Analog input 2*	V
18	Analog input 3*	V
19	Drive temperature	°C

Note: * If P3.31 and P3.33 are set to 1000, analog input 1, analog input 2, and analog input 3 automatically output the voltage that is input from analog input terminals.

P3.30 ¹	Data size	16bit	Data format	DEC
	Modbus address	1660, 1661	CANopen address	0x231E, 0x00
P3.32 ¹	Data size	16bit	Data format	DEC
	Modbus address	1664, 1665	CANopen address	0x2320, 0x00

P3.31	Voltage gain of AO 1	Setting range	Default	Unit	Applicable mode		
		1-214748364	1	[P3.30 unit]/V	P	S	T
P3.33	Voltage gain of AO 2	Setting range	Default	Unit	Applicable mode		
		1-214748364	1	[P3.32 unit]/V	P	S	T

This group of parameter specifies the gain of analog output. The gain units are associated with P3.30 and P3.32.

Example: Assume that the actual speed is output from the terminal AO1, 10V corresponds to the speed of 3000 r/min and 0V corresponds to 0. Then P3.30 must be 1 and P3.31 must be 300. See

the following figure for the relationship between the actual speed reference and output voltage:

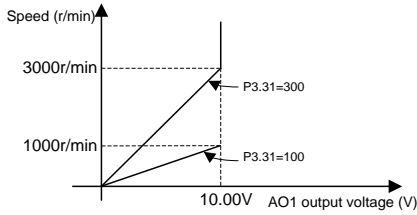

Note:

- In the example, when the actual output speed is 3000 r/min or above, the output voltage of AO1 is always 10V. Select proper gain according to the actual situation.
- If other functions are set for P3.30 and P3.32, the gain setting method is similar.

P3.31	Data size	32bit	Data format	DEC
	Modbus address	1662, 1663	CANopen address	0x231F, 0x00
P3.33	Data size	32bit	Data format	DEC
	Modbus address	1666, 1667	CANopen address	0x2321, 0x00

P3.34	Offset voltage of AO 1	Setting range	Default	Unit	Applicable mode		
		-10.000-10.000	0.000	V	P	S	T
P3.35	Offset voltage of AO 2	Setting range	Default	Unit	Applicable mode		
		-10.000-10.000	0.000	V	P	S	T

This group of parameter is used to adjust voltage of analog output 1 and analog output 2.
 Actual value of analog output voltage = Original value of analog output voltage + Offset value of analog output voltage

P3.34	Data size	32bit	Data format	DEC
	Modbus address	1668, 1669	CANopen address	0x2322, 0x00
P3.35	Data size	32bit	Data format	DEC
	Modbus address	1670, 1671	CANopen address	0x2323, 0x00

P3.36 ¹	AO format	Setting range	Default	Unit	Applicable mode		
		0-2	0	-	P	S	T

This parameter specifies the output mode and voltage range of analog output (AO).

Setting	Meaning
[0]	Voltage output with signs (-10V-10V)
1	Absolute voltage output (0V-10V)
2	Zero-bias voltage output (0V-10V, 5V as the bias center)

P3.36 ¹	Data size	16bit	Data format	DEC
	Modbus address	1672, 1673	CANopen address	0x2324, 0x00

6.4.3 Digital input/output associated settings

P3.40 ¹	Disable travel limit switch	Setting range	Default	Unit	Applicable mode		
		0–2	1	-	P	S	T

This parameter specifies whether the forward drive disabling (0x001 or 0x101) digital input and reverse drive disabling (0x002 or 0x102) digital inputs in P3.00–P3.07 are valid. You can disable the travel limit switch function by setting this parameter.

Setting	Meaning
0	The travel limit switch is valid.
[1]	The travel limit switch is invalid.
2	A limit exceeding fault occurs.

Note: If the travel limit switch is enabled and the digital input of disabling forward drive is valid, the motor stops immediately and does not run forward, but it can receive reverse running commands.

P3.40 ¹	Data size	16bit	Data format	DEC
	Modbus address	1680, 1681	CANopen address	0x2328, 0x00

P3.41 ¹	Disable emergency stop	Setting range	Default	Unit	Applicable mode		
		0–1	1	-	P	S	T

This parameter specifies whether the emergency stop (0x016 or 0x116) digital inputs in P3.00–P3.07 are valid. You can disable the emergency stop function by setting this parameter.

Setting	Meaning
0	The emergency stop switch is valid.
[1]	The emergency stop switch is invalid.

If the digital input of emergency stop is valid, the alarm Er10-4 is reported.

Note:

- If the alarm Er10-4 is reported, the servo motor stops in the mode specified by P4.30.
- To clear the alarm Er10-4, ensure there is no danger for operating, clear the alarm signal (that is, disable the digital input of emergency stop), clear the alarm display, and then restart the servo drive.

P3.41 ¹	Data size	16bit	Data format	DEC
	Modbus address	1682, 1683	CANopen address	0x2329, 0x00

P3.43 ¹	Digital input filter	Setting range	Default	Unit	Applicable mode		
		1–800	1	0.125ms	P	S	T

This parameter specifies the filter time of the digital input.

Note: This parameter independently functions for 10 digital inputs.

P3.43 ¹	Data size	16bit	Data format	DEC		
	Modbus address	1686, 1687	CANopen address	0x232B, 0x00		

P3.44	Disable command pulse inhibition	Setting range	Default	Unit	Applicable mode		
		0–1	0	-	P		

This parameter specifies whether the command pulse inhibition (0x008 or 0x108) digital inputs in P3.00–P3.07 are valid. You can disable the command pulse inhibition function by setting this parameter.

0: The command pulse inhibition function is valid.

1: The command pulse inhibition function is invalid.

P3.44	Data size	16bit	Data format	DEC		
	Modbus address	1688, 1689	CANopen address	0x232C, 0x00		

P3.45 ¹	Residual pulse clearing mode	Setting range	Default	Unit	Applicable mode		
		0–1	1	-	P		

This parameter specifies the valid mode for the residual pulse clearing (0x007 or 0x107) digital inputs in P3.00–P3.07.

Setting	Meaning
0	Clearing by the electrical level
[1]	Clearing by the rising edge

P3.45 ¹	Data size	16bit	Data format	DEC		
	Modbus address	1690, 1691	CANopen address	0x232D, 0x00		

P3.50	Position arrival range	Setting range	Default	Unit	Applicable mode		
		0–2 ¹⁸	100	reference unit	P		

This parameter specifies the position arrival range. If the deviation between the position feedback pulse and position command pulse is in this range, the position is arrived at.

P3.50	Data size	32bit	Data format	DEC		
	Modbus address	1700, 1701	CANopen address	0x2332, 0x00		

P3.51	Output mode of position arrival	Setting range	Default	Unit	Applicable mode		
		0-4	0	-	P		

This parameter specifies the output condition and subsequent action of position arrival.

Setting	Meaning
[0]	The output is valid when the position deviation is in the range of P3.50.
1	The output is valid when there is no position command and the position deviation is in the range of P3.50.
2	The output is valid when there is no position command, the zero-speed detection signal is valid, and the position deviation is in the range of P3.50.
3	The output is valid when there is a transition from with a position command to without a position command and the position deviation is in the range of P3.50. Subsequently, the system continuously outputs the valid state within the time specified by P3.52. Then, the system updates the output status of position arrival based on the position command and position deviation.
4	The output is valid when there is a transition from with a position command to without a position command and the position deviation is in the range of P3.50. Subsequently, the system continuously outputs the valid state within the time specified by P3.52.

P3.51	Data size	16bit	Data format	DEC
	Modbus address	1702, 1703	CANopen address	0x2333, 0x00

P3.52	Hold time of position arrival output terminal	Setting range	Default	Unit	Applicable mode		
		0-30000	0	ms	P		

This parameter specifies the hold time of the position arrival output terminal.

Setting	Meaning
[0]	The hold time is infinite, and the holding is valid until the position in a next position command is arrived at.
1-30000	The holding is valid within the setting range. It becomes invalid once a next position command is received.

P3.52	Data size	16bit	Data format	DEC
	Modbus address	1704, 1705	CANopen address	0x2334, 0x00

P3.53	Speed consistency threshold	Setting range	Default	Unit	Applicable mode		
		10-20000	50	r/min	P	S	T

This parameter specifies the condition for detecting speed consistency.

If the difference between the speed command and motor speed is less than the setting of this

parameter, then the speed consistency output status is valid.

If the detection finds there is a lag of 10 r/min, the actual speed consistency range is as follows:

If the speed consistency output is invalid, the validity threshold is (P3.53 – 10) r/min.

If the speed consistency output is valid, the invalidity threshold is (P3.53 + 10) r/min.

P3.53	Data size	16bit	Data format	DEC
	Modbus address	1706, 1707	CANopen address	0x2335, 0x00

P3.54	Speed reaching range	Setting range	Default	Unit	Applicable mode		
		10–20000	1000	r/min	P	S	T

This parameter specifies the condition for detecting speed reaching output. If the transient motor speed [R0.21] exceeds the setting of this parameter, the output is valid. The detection finds a lag of 10 r/min.

P3.54	Data size	16bit	Data format	DEC
	Modbus address	1708, 1709	CANopen address	0x2336, 0x00

P3.55	Zero speed range	Setting range	Default	Unit	Applicable mode		
		10–20000	50	r/min	P	S	T

This parameter specifies the condition for detecting zero speed output. When the absolute value of the motor speed is within this range, the speed is considered as zero speed and the zero speed output signal is valid. The detection finds a lag of 10 r/min.

P3.55	Data size	16bit	Data format	DEC
	Modbus address	1710, 1711	CANopen address	0x2337, 0x00

P3.56	Servo lock time after braking	Setting range	Default	Unit	Applicable mode		
		0–1000	50	ms	P	S	T

This parameter specifies the locked time of the servo after braking in locked state. If the servo is off in locked state, the digital output of the electromagnetic brake release signal (0x005 or 0x105) is invalid. Then the servo keeps being locked for a period of time so that the motor does not rotate during the action of the relay.

P3.56	Data size	16bit	Data format	DEC
	Modbus address	1712, 1713	CANopen address	0x2338, 0x00

P3.57	Electromagnetic brake closing delay	Setting range	Default	Unit	Applicable mode		
		0–30000	500	ms	P	S	T
<p>This parameter specifies the delay time of closing the electromagnetic brake. If the servo is off or an alarm is reported in running state and the speed may be too fast, the digital output of the electromagnetic brake release signal (0x005 or 0x105) becomes invalid after a period of delay. If the motor speed drops below the setting of P3.58 during the delay period, the digital output becomes invalid in advance.</p>							
P3.57	Data size	16bit	Data format		DEC		
	Modbus address	1714, 1715	CANopen address		0x2339, 0x00		

P3.58 ¹	Motor speed threshold at brake release	Setting range	Default	Unit	Applicable mode		
		0–1000	30	r/min	P	S	T
<p>This parameter specifies the motor speed threshold when the brake is released.</p>							
P3.58 ¹	Data size	16bit	Data format		DEC		
	Modbus address	1716, 1717	CANopen address		0x233A, 0x00		

P3.59	Torque reaching range	Setting range	Default	Unit	Applicable mode		
		5.0–300.0	50.0	%			T
<p>This parameter specifies the condition for detecting torque reaching output. If the motor torque feedback exceeds the setting of this parameter, the output of torque reaching (0x010 or 0x110) is valid. The detection finds a lag of 5%.</p>							
P3.59	Data size	16bit	Data format		DEC		
	Modbus address	1718, 1719	CANopen address		0x233B, 0x00		

P3.77	AI dead zone mode	Setting range	Default	Unit	Applicable mode								
		0–1	0	-	P	S	T						
<p>This parameter specifies the voltage mode of the analog input dead zone.</p> <table border="1" style="width: 100%; border-collapse: collapse;"> <thead> <tr> <th style="width: 15%;">Setting</th> <th>Meaning</th> </tr> </thead> <tbody> <tr> <td>[0]</td> <td>Normal mode</td> </tr> <tr> <td>1</td> <td>CNC mode: If the analog input is equal to or less than the dead zone, the internal control value is 0. If the analog input is greater than the dead zone, the internal control value is (Analog input – Dead zone).</td> </tr> </tbody> </table>								Setting	Meaning	[0]	Normal mode	1	CNC mode: If the analog input is equal to or less than the dead zone, the internal control value is 0. If the analog input is greater than the dead zone, the internal control value is (Analog input – Dead zone).
Setting	Meaning												
[0]	Normal mode												
1	CNC mode: If the analog input is equal to or less than the dead zone, the internal control value is 0. If the analog input is greater than the dead zone, the internal control value is (Analog input – Dead zone).												
P3.77	Data size	16bit	Data format		DEC								
	Modbus address	1754, 1755	CANopen address		0x234D, 0x00								

P3.90	Pulse input filter time	Setting range	Default	Unit	Applicable mode		
		0-7	2	-	P	S	T

This parameter specifies the filter time for detecting pulse input. The effective condition of this parameter is the ideal condition that phase A/B achieves 50% duty cycle and the phase position remains at 90°. If the input pulse signal quality is not good, adjust the filter bandwidth appropriately.

Setting	Detection bandwidth
0	400kHz
1	500kHz
[2]	1MHz
3	2MHz
4	4MHz
5	No filtering
6	200kHz
7	100kHz

P3.90	Data size	16bit	Data format	DEC
	Modbus address	1780, 1781	CANopen address	0x235A, 0x00

P3.92	Pulse feedback filter time	Setting range	Default	Unit	Applicable mode		
		-	-	-	P	S	T

This parameter specifies the filter time for detecting pulse feedback of the incremental encoder.

P3.92	Data size	16bit	Data format	DEC
	Modbus address	1784, 1785	CANopen address	0x235C, 0x00

6.5 Extension and application (group P4)

6.5.1 Communication

P4.00 ¹	Local EtherCAT address	Setting range	Default	Unit	Applicable mode		
		-1-65535	-1	-	P	S	T

This parameter specifies the local (or slave) address for EtherCAT communication. If the parameter is set to -1, the local address is set by the master station.

P4.00 ¹	Data size	16bit	Data format	DEC
	Modbus address	1800, 1801	CANopen address	0x2400, 0x00

P4.01 ¹	Local RS485 address	Setting range	Default	Unit	Applicable mode		
--------------------	---------------------	----------------------	----------------	-------------	------------------------	--	--

		1–255	1	-	P	S	T
--	--	-------	---	---	---	---	---

This parameter specifies the local (or slave) address for RS485 serial communication.

P4.01 ¹	Data size	16bit	Data format	DEC
	Modbus address	1802, 1803	CANopen address	0x2401, 0x00

P4.02 ¹	CAN baud rate	Setting range	Default	Unit	Applicable mode		
		0–5	1	-	P	S	T

This parameter specifies the CAN communication baud rate.

Setting	Meaning
0	1000kbps
[1]	500kbps
2	250kbps
3	125kbps
4	50kbps
5	20kbps

P4.02 ¹	Data size	16bit	Data format	DEC
	Modbus address	1804, 1805	CANopen address	0x2402, 0x00

P4.03 ¹	RS485 baud rate	Setting range	Default	Unit	Applicable mode		
		0–3	1	-	P	S	T

This parameter specifies the RS485 communication baud rate.

Setting	Meaning
0	9600bps
[1]	19200bps
2	38400bps
3	57600bps

P4.03 ¹	Data size	16bit	Data format	DEC
	Modbus address	1806, 1807	CANopen address	0x2403, 0x00

P4.04 ¹	RS485 parity check	Setting range	Default	Unit	Applicable mode		
		0–5	0	-	P	S	T

This parameter specifies the RS485 parity check method, valid only for RTU transmission.

Setting	Meaning
[0]	None (N, 8, 1)
1	Even (E, 8, 1)
2	Odd (O, 8, 1)
3	None (N, 8, 2)
4	Even (E, 8, 2)
5	Odd (O, 8, 2)

P4.04 ¹	Data size	16bit	Data format	DEC		
	Modbus address	1808, 1809	CANopen address	0x2404, 0x00		

P4.05 ¹	CAN node no.	Setting range	Default	Unit	Applicable mode		
		1–127	1	-	P	S	T

This parameter specifies the local (or slave) node number in CAN communication.

P4.05 ¹	Data size	16bit	Data format	DEC		
	Modbus address	1810, 1811	CANopen address	0x2405, 0x00		

P4.06	RS485 fault clearing mode	Setting range	Default	Unit	Applicable mode		
		0–1	1	-	P	S	T

This parameter specifies the mode for handling a fault that occurs in RS485 communication.

Setting	Meaning
0	The fault is not cleared.
[1]	The fault is cleared automatically.

P4.06	Data size	16bit	Data format	DEC		
	Modbus address	1812, 1813	CANopen address	0x2406, 0x00		

P4.07 ¹	EtherCAT synchronization interval	Setting range	Default	Unit	Applicable mode		
		0–3	2	-	P	S	T

This parameter specifies the interval time of synchronization when EtherCAT communication uses the DC mode.

Setting	Meaning
0	250us
1	500us
[2]	1ms
3	2ms

P4.07 ¹	Data size	16bit	Data format	DEC
	Modbus address	1814, 1815	CANopen address	0x2407, 0x00

P4.08 ¹	EtherCAT synchronization type	Setting range	Default	Unit	Applicable mode		
		0–2	0	-	P	S	T

This parameter specifies the type of synchronization between the master and slave nodes in EtherCAT communication.

Setting	Meaning
[0]	Free-run
2	DC mode (sync0)

P4.08 ¹	Data size	16bit	Data format	DEC
	Modbus address	1816, 1817	CANopen address	0x2408, 0x00

P4.09 ¹	EtherCAT fault detection time	Setting range	Default	Unit	Applicable mode		
		0–1000	100	ms	P	S	T

This parameter specifies the fault detection time in EtherCAT communication.

Note: The value 0 indicates EtherCAT faults are not detected.

P4.09 ¹	Data size	16bit	Data format	DEC
	Modbus address	1818, 1819	CANopen address	0x2409, 0x00

6.5.2 Servo types and communication control commands

P4.10 ¹	Upper computer type	Setting range	Default	Unit	Applicable mode		
		0–1	0	-	P	S	T

This parameter specifies the upper computer type which is identified by the drive control interface type of the upper computer.

Setting	Upper computer type	Control interface type
[0]	Pulse + analog	Position control/fully-closed-loop: pulse and PTP control Speed/torque control: analog and internal settings
1	Communication bus	RS485 (protocol: Modbus) CAN (protocol: CANopen CiA301/402)

P4.10 ¹	Data size	16bit	Data format	DEC
	Modbus address	1820, 1821	CANopen address	0x240A, 0x00

P4.11*	Enable bus servo	Setting range	Default	Unit	Applicable mode		
--------	------------------	----------------------	----------------	-------------	------------------------	--	--

		0-1	0	-	P	S	T
--	--	-----	---	---	---	---	---

This parameter specifies whether to enable the drive.

Setting	Meaning
[0]	Disable
1	Enable

Note: Though the drive has been enabled by setting P0.04, the drive will be disabled when P4.11 is changed from 1 to 0.

P4.11*	Data size	16bit	Data format	DEC
	Modbus address	1822, 1823	CANopen address	0x240B, 0x00

P4.12*	Bus position command	Setting range	Default	Unit	Applicable mode		
		$-(2^{31}-1)-(2^{31}-1)$	0	reference unit	P		

This parameter specifies the position command for the drive when P4.10 is set to 1.

P4.12*	Data size	32bit	Data format	DEC
	Modbus address	1824, 1825	CANopen address	0x240C, 0x00

P4.13*	Bus speed command	Setting range	Default	Unit	Applicable mode		
		-6000.0 - 6000.0	0	r/min		S	

This parameter specifies the speed command for the drive when P4.10 is set to 1.

P4.13*	Data size	32bit	Data format	DEC
	Modbus address	1826, 1827	CANopen address	0x240D, 0x00

P4.14*	Bus torque command	Setting range	Default	Unit	Applicable mode		
		-500.0-500.0	0.0	%			T

This parameter specifies the torque command for the drive when P4.10 is set to 1.

P4.14*	Data size	16bit	Data format	DEC
	Modbus address	1828, 1829	CANopen address	0x240E, 0x00

P4.15*	Control mode switching command	Setting range	Default	Unit	Applicable mode		
		0-1	0	-	P	S	T

This parameter specifies whether to enable control mode switching of the drive when the hybrid control mode is used. Control mode switching is valid in enabled state.

Setting	Meaning	Actual control mode	
[0]	Disable	Position/speed	Position
		Position/torque	Position
		Speed/torque	Speed
1	Enable	Position/speed	Speed
		Position/torque	Torque
		Speed/torque	Torque

Note: If the control mode switching command is updated, the actual switching process of the drive and motor is handled based on the settings of P0.90–P0.92 and actual feedback state.

P4.15*	Data size	16bit	Data format	DEC
	Modbus address	1830, 1831	CANopen address	0x240F, 0x00

P4.16*	Gain switching command	Setting range	Default	Unit	Applicable mode		
		0–1	0	-	P	S	T

This parameter specifies whether to enable gain switching for the drive. When P2.22, P2.27, and P2.31 are set to 2, the actual gain settings are used for switching.

Setting	Meaning	Actual gain
[0]	Disable	Set by the first gain
1	Enable	Set by the second gain

P4.16*	Data size	16bit	Data format	DEC
	Modbus address	1832, 1833	CANopen address	0x2410, 0x00

P4.17*	Electronic gear ratio switching command	Setting range	Default	Unit	Applicable mode		
		0–3	0	-	P		

This parameter is used to switch electronic gear ratios for the drive when P4.10 is set to 1.

Setting	Numerator of actual electronic gear ratio	Denominator of actual electronic gear ratio
[0]	Numerator of electronic gear ratio 1 (P0.25)	Denominator of electronic gear ratio (P0.26)
1	Numerator of electronic gear ratio 2 (P0.27)	
2	Numerator of electronic gear ratio 3 (P0.28)	
3	Numerator of electronic gear ratio 4 (P0.29)	

P4.17*	Data size	16bit	Data format	DEC
	Modbus address	1834, 1835	CANopen address	0x2411, 0x00

P4.18*	Inertia ratio switching command	Setting range	Default	Unit	Applicable mode
--------	---------------------------------	----------------------	----------------	-------------	------------------------

		0-1	0	-	P	S	T
This parameter specifies whether to enable inertia ratio switching for the drive.							
Setting		Meaning		Actual inertia ratio			
[0]		Disable		Inertia ratio 1 (P1.01)			
1		Enable		Inertia ratio 1 (P1.02)			
P4.18*	Data size	16bit		Data format		DEC	
	Modbus address	1836, 1837		CANopen address		0x2412, 0x00	

P4.19*	Zero speed clamp command	Setting range	Default	Unit	Applicable mode		
		0-1	0	-		S	T
This parameter specifies whether to enable zero speed clamp.							
Setting		Meaning					
[0]		Disable					
1		Enable					
P4.19*	Data size	16bit		Data format		DEC	
	Modbus address	1838, 1839		CANopen address		0x2413, 0x00	

P4.20*	Clearing residual pulses	Setting range	Default	Unit	Applicable mode		
		0-1	0	-	P		
This parameter specifies whether to enable residual pulse clearing for the drive. P3.45 specifies the mode for clearing residual pulses. If residual pulses are cleared, R0.04 is changed to 0.							
Setting		Meaning					
[0]		Disable					
1		Enable					
P4.20*	Data size	16bit		Data format		DEC	
	Modbus address	1840, 1841		CANopen address		0x2414, 0x00	

P4.21*	Torque limit switching command	Setting range	Default	Unit	Applicable mode		
		0-1	0	-	P	S	T
This parameter specifies whether to enable torque limit switching for the drive.							
Setting		Meaning					
[0]		Disable					
1		Enable					
P4.21*	Data size	16bit		Data format		DEC	
	Modbus address	1842, 1843		CANopen address		0x2415, 0x00	

P4.22*	External fault reporting command	Setting range	Default	Unit	Applicable mode		
		0-1	0	-	P	S	T
This parameter specifies whether to enable external fault reporting for the drive.							
		Setting	Meaning				
		[0]	Disable				
		1	Enable				
P4.22*	Data size	16bit	Data format	DEC			
	Modbus address	1844, 1845	CANopen address	0x2416, 0x00			

P4.23*	Emergency stop command	Setting range	Default	Unit	Applicable mode		
		0-1	0	-	P	S	T
This parameter specifies whether to enable emergency stop for the drive.							
		Setting	Meaning				
		[0]	Disable				
		1	Enable				
P4.23*	Data size	16bit	Data format	DEC			
	Modbus address	1846, 1847	CANopen address	0x2417, 0x00			

P4.24*	Vibration control switching command	Setting range	Default	Unit	Applicable mode		
		0-1	0	-	P		
This parameter specifies whether to enable vibration control switching for the drive.							
		Setting	Meaning				
		[0]	Disable				
		1	Enable				
P4.24*	Data size	16bit	Data format	DEC			
	Modbus address	1848, 1849	CANopen address	0x2418, 0x00			

6.5.3 Extension and application

P4.30	Stop mode	Setting range	Default	Unit	Applicable mode		
		0-3	0	-	P	S	T
This parameter specifies whether the dynamic brake works when the servo is off and a fault alarm is reported and determine the servo motor status after the stop.							

Setting	Action	
	During deceleration	After stop
[0]	The motor coasts to stop.	Inertia running kept
1	The motor stops through the dynamic brake.	Inertia running kept
2	The dynamic brake stops.	Dynamic braking
3	The external dynamic brake acts.	Dynamic braking

Note:

- If P4.30 is set to 1, the dynamic brake works when the motor speed is higher than the setting (30 r/min by default) of P3.58 and it does not work otherwise. After the motor stops, the dynamic brake does not work.
- If the servo motor runs at a speed higher than the rated one, you cannot enable the dynamic brake. If the servo motor runs at a high speed with a large inertia load, exercise caution before using the dynamic brake. Do not restart the dynamic brake frequently. Otherwise, the servo drive may be damaged.

P4.30	Data size	16bit	Data format	DEC
	Modbus address	1860, 1861	CANopen address	0x241E, 0x00

P4.31	Max. motor speed	Setting range	Default	Unit	Applicable mode		
		0–20000	5000	r/min	P	S	T

This parameter specifies the maximum speed of the servo motor. If the absolute value of the speed command is greater than the setting of this parameter, the actually-set speed is limited by this parameter, and the actual direction is the same as that in the original speed command. This parameter is valid in all modes.

Note: The default value and setting range of this parameter are associated with the drive power class.

P4.31	Data size	16bit	Data format	DEC
	Modbus address	1862, 1863	CANopen address	0x241F, 0x00

P4.32	Overspeed threshold	Setting range	Default	Unit	Applicable mode		
		0–20000	6000	r/min	P	S	T

This parameter specifies the overspeed level for the servo motor. When the motor runs at a speed higher than the setting of this parameter, an overspeed fault alarm is reported. When P4.32 is set to 0, the overspeed fault alarm is screened out.

Note: The default value and setting range of this parameter are associated with the drive power class.

P4.32	Data size	16bit	Data format	DEC
	Modbus address	1864, 1865	CANopen address	0x2420, 0x00

P4.33	Pulse threshold of position deviation	Setting range	Default	Unit	Applicable mode		
		0–2 ²⁷	100000	reference unit	P		
This parameter specifies the threshold at which the fault (Er22-0) alarm is reported. In position mode, if the residual pulse value exceeds the setting of this parameter, the fault alarm is reported. The value 0 indicates no detection on position deviation.							
P4.33	Data size	32bit	Data format	DEC			
	Modbus address	1866, 1867	CANopen address	0x2421, 0x00			

P4.34 ¹	Brake OL protection	Setting range	Default	Unit	Applicable mode		
		0–2	0	-	P	S	T
This parameter specifies the regenerative brake mounting mode and overload protection mode.							
		Setting	Meaning				
		[0]	Regenerative brake disabled				
		1	Regenerative brake built in				
		2	Regenerative brake externally connected				

P4.34 ¹	Data size	16bit	Data format	DEC			
	Modbus address	1868, 1869	CANopen address	0x2422, 0x00			

P4.35	Enabling motor runaway detection	Setting range	Default	Unit	Applicable mode		
		0–1	1	-	P	S	T
This parameter specifies whether to enable the motor runaway detection function.							
		Setting	Meaning				
		0	Disable				
		[1]	Enable				

P4.35	Data size	16bit	Data format	DEC			
	Modbus address	1870, 1871	CANopen address	0x2423, 0x00			

P4.36 ¹	Main-power UV protection	Setting range	Default	Unit	Applicable mode		
		0–1	1	-	P	S	T

This parameter specifies whether the drive reports a main circuit undervoltage alarm when the main power encounters a main circuit undervoltage fault.

Setting	Meaning
0	In servo enabling state, the drive does not report the fault Er13-1 when main circuit undervoltage occurs.
[1]	In servo enabling state, the drive reports the fault Er13-1 and stops when main circuit undervoltage occurs.

P4.36 ¹	Data size	16bit	Data format	DEC
	Modbus address	1872, 1873	CANopen address	0x2424, 0x00

P4.37	Main-power UV detection time	Setting range	Default	Unit	Applicable mode		
		70–2000	70	ms	P	S	T

This parameter specifies the time taken to detect main power undervoltage.

Note: The value 0 indicates the function of detecting main power undervoltage is invalid.

P4.37	Data size	16bit	Data format	DEC
	Modbus address	1874, 1875	CANopen address	0x2425, 0x00

P4.38	Motor overload rate	Setting range	Default	Unit	Applicable mode		
		0.0–500.0	115.0	%	P	S	T

This parameter specifies the motor overload rate.

The default value is 115.0%. When increasing this value, consider the motor overload capacity carefully.

P4.38	Data size	16bit	Data format	DEC
	Modbus address	1876, 1877	CANopen address	0x2426, 0x00

P4.39	Speed deviation threshold	Setting range	Default	Unit	Applicable mode		
		0–20000	0	r/min	P	S	

This parameter specifies the condition for detecting the speed deviation fault. If the absolute value of the actual speed command minus the motor speed is greater than the setting of this parameter and the deviation lasts more than 100ms, a speed deviation alarm is reported.

Note: The value 0 indicates no detection on speed deviation faults.

P4.39	Data size	16bit	Data format	DEC
	Modbus address	1878, 1879	CANopen address	0x2427, 0x00

P4.40	Forward speed limit	Setting range	Default	Unit	Applicable mode		
		0–20000	20000	r/min	P	S	T
<p>This parameter specifies the maximum limit on the forward speed command.</p> <p>Note: The default value and setting range of this parameter are associated with the drive power class.</p>							
P4.40	Data size	16bit	Data format	DEC			
	Modbus address	1880, 1881	CANopen address	0x2428, 0x00			

P4.41	Reverse speed limit	Setting range	Default	Unit	Applicable mode		
		-20000–0	-20000	r/min	P	S	T
<p>This parameter specifies the maximum limit on the reverse speed command.</p> <p>Note: The default value and setting range of this parameter are associated with the drive power class.</p>							
P4.41	Data size	16bit	Data format	DEC			
	Modbus address	1882, 1883	CANopen address	0x2429, 0x00			

P4.42	Internal speed with high resolution	Setting range	Default	Unit	Applicable mode		
		-20000.0–20000.0	0.0	r/min		S	
<p>This parameter specifies the internal speed with high resolution.</p>							
P4.42	Data size	32bit	Data format	DEC			
	Modbus address	1884, 1885	CANopen address	0x242A, 0x00			

P4.43	Speed threshold for motor runaway protection	Setting range	Default	Unit	Applicable mode		
		0.0–2000.0	30.0	r/min		S	
<p>This parameter specifies the speed threshold for motor runaway protection. A smaller value indicates more sensitive.</p>							
P4.43	Data size	32bit	Data format	DEC			
	Modbus address	1886, 1887	CANopen address	0x242B, 0x00			

P4.45	OT threshold of medium-power motor	Setting range	Default	Unit	Applicable mode		
		0–200	0	°C	P	S	T
<p>Temperature sampling from temperature resistor KTY84-130 is supported. If the temperature exceeds the setting of this parameter, a motor overtemperature (OT) fault is reported. The value 0</p>							

indicates temperature sampling is not conducted.				
P4.45	Data size	16bit	Data format	DEC
	Modbus address	1890, 1891	CANopen address	0x242D, 0x00

P4.50 ¹	Encoder phase-Z offset	Setting range	Default	Unit	Applicable mode		
		0–(2 ²⁰ -1)	0	pulse	P	S	T

This parameter specifies the output position of phase Z. The phase Z offset is the pulses in the CCW direction.

P4.50 ¹	Data size	32bit	Data format	DEC
	Modbus address	1900, 1901	CANopen address	0x2432, 0x00

P4.51	Torque limit switching time 1	Setting range	Default	Unit	Applicable mode		
		0–4000	0	ms/(100%)	P	S	

This parameter specifies the time taken to switch from the first torque limit to the second torque limit.

P4.51	Data size	16bit	Data format	DEC
	Modbus address	1902, 1903	CANopen address	0x2433, 0x00

P4.52	Torque limit switching time 2	Setting range	Default	Unit	Applicable mode		
		0–4000	0	ms/(100%)	P	S	

This parameter specifies the time taken to switch from the second torque limit to the first torque limit.

P4.52	Data size	16bit	Data format	DEC
	Modbus address	1904, 1905	CANopen address	0x2434, 0x00

P4.53	ACR response adjustment	Setting range	Default	Unit	Applicable mode		
		10.0–200.0	100.0	%	P	S	T

This parameter specifies the adjustment coefficient of automatic current regulator response width.

P4.53	Data size	16bit	Data format	DEC
	Modbus address	1906, 1907	CANopen address	0x2435, 0x00

P4.54 ¹	Delay after power-on initialization	Setting range	Default	Unit	Applicable mode		
		0–200000	0	ms	P	S	T

This parameter specifies the delay time of servo enabling after power-on initialization is completed.

P4.54 ¹	Data size	32bit	Data format	DEC
	Modbus address	1908, 1909	CANopen address	0x2436, 0x00

6.5.4 Frequency-division output and second-encoder settings

P4.60 ¹	Frequency-division numerator of external grating ruler	Setting range	Default	Unit	Applicable mode		
		1–(2 ³¹ -1)	10000	-	P		

This parameter specifies the frequency-division numerator of the external grating ruler.

P4.60 ¹	Data size	32bit	Data format	DEC
	Modbus address	1920, 1921	CANopen address	0x243C, 0x00

P4.61 ¹	Frequency-division denominator of external grating ruler	Setting range	Default	Unit	Applicable mode		
		1–(2 ³¹ -1)	10000	-	P		

This parameter specifies the frequency-division denominator of the external grating ruler. It corresponds to the grating ruler pulses needed for each motor rotation.

P4.61 ¹	Data size	32bit	Data format	DEC
	Modbus address	1922, 1923	CANopen address	0x243D, 0x00

P4.62 ¹	Reverse external grating ruler count	Setting range	Default	Unit	Applicable mode		
		0–1	0	-	P		

This parameter specifies whether to reverse the count from the external grating ruler.

Setting	Meaning
[0]	Use the count from the external grating ruler directly.
1	Reverse the count from the external grating ruler and then use the reversed count.

P4.62 ¹	Data size	16bit	Data format	DEC
	Modbus address	1924, 1925	CANopen address	0x243E, 0x00

P4.64 ¹	Hybrid control deviation limit	Setting range	Default	Unit	Applicable mode		
		1–2 ²⁷	160000	reference unit	P		

In fully-closed loop control, there is a tolerance between the reference unit corresponding to the encoder feedback position and user reference unit corresponding to the grating ruler feedback position. The tolerance is called hybrid-control deviation, specified by R0.05. If R0.05 exceeds the setting of this parameter, the drive reports fault Er22-1.

P4.64 ¹	Data size	32bit	Data format	DEC
	Modbus address	1928, 1929	CANopen address	0x2440, 0x00

P4.65 ¹	Threshold for hybrid-control deviation clearing	Setting range	Default	Unit	Applicable mode		
		0–100	0	rotations	P		

This parameter specifies the condition for clearing the hybrid-control deviation. When the motor rotation number reaches the specified one, the hybrid-control deviation is cleared. The value 0 indicates the hybrid-control deviation is not cleared.

P4.65 ¹	Data size	16bit	Data format	DEC
	Modbus address	1930, 1931	CANopen address	0x2441, 0x00

P4.67 ¹	Signal source of pulse feedback output	Setting range	Default	Unit	Applicable mode		
		0–1	0	-	P		

This parameter specifies the signal source of pulse feedback output when the fully-closed loop function is enabled in position mode.

Setting	Meaning
[0]	Encoder
1	Grating ruler

P4.67 ¹	Data size	16bit	Data format	DEC
	Modbus address	1934, 1935	CANopen address	0x2443, 0x00

P4.68 ¹	External grating ruler (or encoder 2) resolution	Setting range	Default	Unit	Applicable mode		
		1–(2 ³¹ -1)	10000	pulse	P		

This parameter specifies the resolution of the external grating ruler (or second encoder). If the second encoder is connected, the output is the pulses needed for each encoder rotation.

P4.68 ¹	Data size	32bit	Data format	DEC
	Modbus address	1936, 1937	CANopen address	0x2444, 0x00

P4.69 ¹	Frequency division output source	Setting range	Default	Unit	Applicable mode		
		0–4	0	-	P	S	T

This parameter specifies the signal source of frequency division output.

Setting	Meaning
[0]	Normal frequency division output
1	Second encoder
2	Input from quadrature pulses in phases A and B
3	Internal virtual shaft
4	First encoder (valid only for incremental encoders)

P4.69 ¹	Data size	32bit	Data format	DEC
	Modbus address	1938, 1939	CANopen address	0x2445, 0x00

P4.70 ¹	External grating ruler (or encoder 2) phase-Z signal type	Setting range	Default	Unit	Applicable mode		
		0-3	0	-	P	S	T

The width for a phase-Z signal can be 1/4, 1/2, or 1/1. The starting phase of a signal in any width corresponds to 4 types of electrical level in phases A and B. There are total 12 types in combination. However, to ensure these combinations are applicable and the capture value is normal in both forward and reverse directions, you need to set the phase-A–phase-B status values in the high electrical level period of phase-Z signals. For the signals in 1/4 and 1/2 widths, only one of phase-A–phase-B status values in the high electrical level period is required after the phase-Z signal type is set. For the signals in 1/1 width, the phase-Z signal type must be the phase-A–phase-B status value in the high electrical level period.

P4.70 ¹	Data size	16bit	Data format	DEC
	Modbus address	1940, 1941	CANopen address	0x2446, 0x00

P4.71	Type of encoder 2	Setting range	Default	Unit	Applicable mode		
		1-12	2* ¹	-	P	S	T

This parameter specifies the type of the second encoder.

Setting	Meaning
1	2500-PPR standard incremental type
[2]	2500-PPR economical incremental type
3	17-bit single-turn absolute type
4	17-bit multiturn absolute type * ³
8	Rotary transformer
10	23-bit multiturn absolute type * ³
Other	Reserved

P4.71	Data size	16bit	Data format	DEC
	Modbus address	1942, 1943	CANopen address	0x2447, 0x00

P4.72	Cascading mode of encoder 2	Setting range	Default	Unit	Applicable mode		
		1-12	0	-	P	S	T

This parameter specifies the cascading mode of the second encoder.

Setting	Meaning
[0]	No cascading
1	Slave node of RS485 synchronization.
2	Master node of RS485 synchronization.
3	The second encoder is cascaded to the slave node.
4	The second encoder is cascaded to the master node.

P4.72	Data size	16bit	Data format	DEC
	Modbus address	1944, 1945	CANopen address	0x2448, 0x00

P4.87	CANopen communication cycle	Setting range	Default	Unit	Applicable mode		
		0-(2 ³¹ -1)	0	μs	P	S	T

This parameter specifies the synchronization signal creation cycle of a slave CANopen node.

Note: The recommended unit is 1000μs.

P4.87	Data size	32bit	Data format	DEC
	Modbus address	1974, 1975	CANopen address	0x2457, 0x00

P4.88	CANopen heartbeat cycle	Setting range	Default	Unit	Applicable mode		
		0-32767	1000	ms	P	S	T

This parameter specifies the heartbeat signal creation cycle of a slave CANopen node.

P4.88	Data size	16bit	Data format	DEC
	Modbus address	1976, 1977	CANopen address	0x2458, 0x00

P4.89	Auto stop on CANopen disconnection	Setting range	Default	Unit	Applicable mode		
		0-1	0	-	P	S	T

This parameter specifies whether to enable automatic stop when CANopen communication is disconnected.

Setting	Meaning
[0]	Disable
1	Enable

P4.89	Data size	16bit	Data format	DEC
	Modbus address	1978, 1979	CANopen address	0x2459, 0x00

6.5.5 Special commands

P4.90*	Fault recovery	Setting range	Default	Unit	Applicable mode		
		0-1	0	-	P	S	T

This parameter specifies whether to enable fault recovery. You can set this parameter on the upper computer to handle faults for the drive.

Setting	Meaning
[0]	Disable
1	Enable

Note:

- If fault recovery is enabled, the servo is not enabled for the drive, and the fault occurring condition is not triggered, the fault that can be automatically cleared recovers automatically. Other faults cannot be automatically cleared online but can be cleared after repower-on.
- You can set this parameter on the LED panel to clear faults.

P4.90*	Data size	16bit	Data format	DEC
	Modbus address	1980, 1981	CANopen address	0x245A, 0x00

P4.91*	Parameter saving	Setting range	Default	Unit	Applicable mode		
		0-1	0	-	P	S	T

If P0.17 is set to 1 (saving in batches), this parameter can be used to send a parameter saving command so that any parameter modification can be written to the EEPROM.

Setting	Meaning
[0]	Disable
1	Enable

P4.91*	Data size	16bit	Data format	DEC
	Modbus address	1982, 1983	CANopen address	0x245B, 0x00

P4.92*	Factory restore	Setting range	Default	Unit	Applicable mode		
		0-1	0	-	P	S	T

This parameter specifies whether to enable the function of restoring factory settings. If the function is enabled, all user parameters (from group P0 to group P6) are restored to factory settings.

Setting	Meaning
[0]	Disable
1	Enable

P4.92*	Data size	16bit	Data format	DEC
	Modbus address	1984, 1985	CANopen address	0x245C, 0x00

P4.93*	Read fault records	Setting range	Default	Unit	Applicable mode		
		0-1	0	-	P	S	T

This parameter specifies whether to enable the function of reading fault records. If the function is enabled, the fault records specified by P4.95 are read and displayed.

Setting	Meaning
[0]	Disable
1	Enable

P4.93*	Data size	16bit	Data format	DEC
	Modbus address	1986, 1987	CANopen address	0x245D, 0x00

P4.94*	Clear fault records	Setting range	Default	Unit	Applicable mode		
		0-1	0	-	P	S	T

This parameter specifies whether to enable the function of clearing fault records. If the function is enabled, all the fault records are cleared.

Setting	Meaning
[0]	Disable
1	Enable

P4.94*	Data size	16bit	Data format	DEC
	Modbus address	1988, 1989	CANopen address	0x245E, 0x00

P4.95*	Fault record group no.	Setting range	Default	Unit	Applicable mode		
		0-9	0	-	P	S	T

This parameter specifies the group number of fault records that are read. The value 0 indicates the fault records in group 1 are read and the faults have occurred most recently. The value 9 indicates the fault records in group 10 are read and the faults have occurred earliest.

P4.95*	Data size	16bit	Data format	DEC
	Modbus address	1990, 1991	CANopen address	0x245F, 0x00

P4.96*	Reserved	Setting range	Default	Unit	Applicable mode		
		-	-	-	P	S	T

This parameter cannot be modified.

P4.96*	Data size	16bit	Data format	DEC
	Modbus address	1992, 1993	CANopen address	0x2460, 0x00

P4.97*	Write to encoder EEPROM	Setting range	Default	Unit	Applicable mode		
		0-1	0	-	P	S	T
<p>This parameter specifies whether to write all motor-related parameters to the EEPROM equipped with the communication encoder. In any following startup, the drive uses the data in the EEPROM for parameter initialization.</p>							
P4.97*	Data size	16bit	Data format	DEC			
	Modbus address	1994, 1995	CANopen address	0x2461, 0x00			

P4.98	Mask encoder EEPROM data faults	Setting range	Default	Unit	Applicable mode		
		0-1	0	-	P	S	T
<p>This parameter specifies whether to mask the fault indicating there is no data or incorrect data on the EEPROM equipped with the communication encoder.</p> <p>If fault Er2-c or Er2-d occurs but the motor model is set correctly, you can use the motor after repower-on. The drive uses the motor data in the EEPROM equipped with the drive for parameter initialization.</p>							
P4.98	Data size	16bit	Data format	DEC			
	Modbus address	1996, 1997	CANopen address	0x2462, 0x00			

6.6 Program Jog, homing, and PTP control (group P5)

6.6.1 Program Jog settings

P5.00	Jog mode	Setting range	Default	Unit	Applicable mode		
		0-6	0	-	P		
<p>This parameter specifies the program Jog mode.</p>							
Mode	Key	Function					
[0]		<p>(Wait time P5.04 → Forward moving P5.01) × Cycles P5.05</p>					
1		<p>(Wait time P5.04 → Forward moving P5.01) × Cycles P5.05</p>					

2		<p>(Wait time P5.04→Forward moving P5.01) × Cycles P5.05 →(Wait time P5.04→Reverse movingP5.01) × Cycles P5.05</p>
3		<p>(Wait time P5.04→Reverse moving P5.01) × Cycles P5.05 →(Wait time P5.04→Forward moving P5.01) × Cycles P5.05</p>
4		<p>(Wait time P5.04→Forward moving P5.01→Wait time P5.04 →Reverse moving P5.01) × Cycles P5.05</p>
5		<p>(Wait time P5.04→Reverse moving P5.01→Wait time P5.04 →Forward moving P5.01) × Cycles P5.05</p>
6		<p>(Wait time P5.04→Forward/reverse moving P5.01) × 1 cycle</p>

P5.00	Data size	16bit	Data format	DEC
	Modbus address	2000, 2001	CANopen address	0x2500, 0x00

P5.01	Jogging increment	Setting range	Default	Unit	Applicable mode	
		1-2 ³⁰	50000	reference unit	P	

This parameter specifies the increment of the position movement at jogging.

P5.01	Data size	32bit	Data format	DEC
	Modbus address	2002, 2003	CANopen address	0x2501, 0x00

P5.02	Jogging speed	Setting range	Default	Unit	Applicable mode	
		1-5000	500	r/min	P	

This parameter specifies the maximum running speed at jogging.

P5.02	Data size	16bit	Data format	DEC
	Modbus address	2004, 2005	CANopen address	0x2502, 0x00

P5.03	Jogging ACC/DEC time	Setting range	Default	Unit	Applicable mode		
		2–10000	100	ms	P		

This parameter specifies the acceleration or deceleration time at jogging. The setting of this parameter corresponds to the time taken to accelerate from the zero speed to the rated rotation speed. If you need to improve the speed from zero to 50% of the rated speed, the time taken to reach the target speed is 50% of the time specified by this parameter.

P5.03	Data size	16bit	Data format	DEC			
	Modbus address	2006, 2007	CANopen address	0x2503, 0x00			

P5.04	Jogging wait time	Setting range	Default	Unit	Applicable mode		
		0–10000	100	ms	P		

This parameter specifies the wait time at jogging. The setting of this parameter corresponds to the time from jogging starting to the actual running or to the time taken to wait for next displacement after the current displacement.

P5.04	Data size	16bit	Data format	DEC			
	Modbus address	2008, 2009	CANopen address	0x2504, 0x00			

P5.05	Jogging cycles	Setting range	Default	Unit	Applicable mode		
		0–10000	1	-	P		

This parameter specifies the number of jogging cycles. For details, see the description for P5.00.

P5.05	Data size	16bit	Data format	DEC			
	Modbus address	2010, 2011	CANopen address	0x2505, 0x00			

6.6.2 Homing

P5.10 ²	Homing mode	Setting range	Default	Unit	Applicable mode		
		0–128	0	-	P		

This parameter specifies the homing mode.

Display mode: DEC

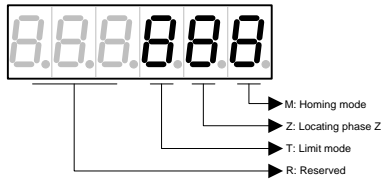

R	T	Z	M		
	Limit mode	Phase Z locating mode	Home return mode		
	0-1	0-2	0-8		
	T: Invalid	Returning to locate phase Z is defined as the home position.	M=0: Forward rotation. The forward limit switch is the recurrent point.		
	T: Invalid	Z=1: Forwarding to locate phase Z is defined as the home position.	M=1: Reverse rotation. The reverse limit switch is the recurrent point.		
Reserved	Limit encountered: T=0: Report an offside fault. T=1: Reverse the direction.	Z=2: No locating phase Z. The recurrent point is defined as the home position.	M=2: Forward rotation. The rising edge of the home switch is the recurrent point.		
		Z: Invalid	M=3: Reverse rotation. The rising edge of the reverse limit switch is the recurrent point.		
		Z: Invalid	M=4: Forward rotation. The first phase-Z signal is the recurrent point.		
		Z: Invalid	M=5: Reverse rotation. The first phase-Z signal is the recurrent point.		
		Z=0 Returning to locate phase Z is defined as the home position.	M=6: Forward rotation. The falling edge of the home switch is the recurrent point.		
			Z=1 Forwarding to locate phase Z is defined as the home position.	M=7: Reverse rotation. The falling edge of the home switch is the recurrent point.	
	T: Invalid	Z: Invalid	M=8: The current position is regarded as the home position.		
P5.10 ²	Data size		16bit	Data format	DEC
	Modbus address		2020, 2021	CANopen address	0x2505, 0x00

P5.11	Homing upon power-on	Setting range	Default	Unit	Applicable mode		
		0-1	0	-	P		

This parameter specifies whether to return to the home position automatically upon power-on.

Setting	Meaning
[0]	Disable
1	Enable

Note: Automatic homing upon power-on is valid only when there is no fault.

P5.11	Data size	16bit	Data format	DEC
	Modbus address	2022, 2023	CANopen address	0x250B, 0x00

P5.12	High speed at homing step 1	Setting range	Default	Unit	Applicable mode	
		0-2000	100	r/min	P	

This parameter specifies the high speed at step 1 of homing.

Diagram:

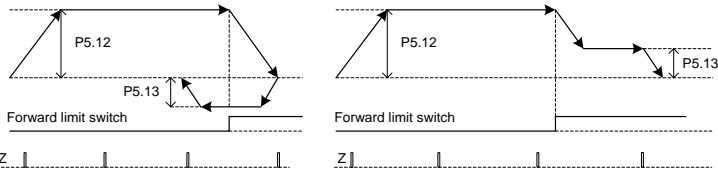

P5.12	Data size	16bit	Data format	DEC
	Modbus address	2024, 2025	CANopen address	0x250C, 0x00

P5.13	Low speed at homing step 2	Setting range	Default	Unit	Applicable mode	
		0-60	20	r/min	P	

This parameter specifies the low speed at step 2 of homing. For details, see the diagram in the description for P5.12.

P5.13	Data size	16bit	Data format	DEC
	Modbus address	2026, 2027	CANopen address	0x250D, 0x00

P5.14	Home position	Setting range	Default	Unit	Applicable mode	
		$-(2^{31}-1)-(2^{31}-1)$	0	reference unit	P	

This parameter specifies the home position.

P5.14	Data size	32bit	Data format	DEC
	Modbus address	2028, 2029	CANopen address	0x250E, 0x00

P5.15*	Homing trigger command	Setting range	Default	Unit	Applicable mode		
		0–1	0	-	P		

This parameter specifies whether to trigger the homing function. It has the same function as the homing trigger terminal with digital input.

P5.15*	Data size	16bit	Data format	DEC			
	Modbus address	2030, 2031	CANopen address	0x250F, 0x00			

P5.16	Homing associated action	Setting range	Default	Unit	Applicable mode		
		0–3	1	-	P		

This parameter specifies the action associated with homing.

Setting	Meaning
0	No action.
[1]	The drive goes to the target position.
2	The drive goes to the position of segment 0.
3	The drive goes to the target position without homing.

P5.16	Data size	16bit	Data format	DEC			
	Modbus address	2032, 2033	CANopen address	0x2510, 0x00			

P5.17	Target speed after homing	Setting range	Default	Unit	Applicable mode		
		1–5000	100	r/min	P		

This parameter specifies the target speed after homing. The change takes effect before homing.

P5.17	Data size	16bit	Data format	DEC			
	Modbus address	2034, 2035	CANopen address	0x2511, 0x00			

P5.18	ACC/DEC time for target speed after homing	Setting range	Default	Unit	Applicable mode		
		0–32767	300	ms	P		

This parameter specifies the acceleration or deceleration time taken to reach the target speed after homing. The setting of this parameter corresponds to the time taken to accelerate from the zero speed to the rated rotation speed. If you need to improve the speed from zero to 50% of the rated speed, the time taken to reach the target speed is 50% of the time specified by this parameter.

P5.18	Data size	16bit	Data format	DEC			
	Modbus address	2036, 2037	CANopen address	0x2512, 0x00			

P5.19	Target position after homing	Setting range	Default	Unit	Applicable mode		
		$-(2^{31}-1)-(2^{31}-1)$	0	reference unit	P		
This parameter specifies the target position after homing.							
P5.19	Data size	32bit	Data format		DEC		
	Modbus address	2038, 2039	CANopen address		0x2513, 0x00		

6.6.3 PTP control

P5.20*	PTP trigger signal	Setting range	Default	Unit	Applicable mode		
		-1–2048	-1	-	P		
This parameter specifies whether to trigger the target segment. If data is written, PTP is triggered, and the internal buffer can receive 8 trigger signals at most.							
Setting		Meaning					
[-1]		Invalid.					
0-127		It triggers PTP control for PTPs 0–127, which equals the digital input of TRIG+POS _n .					
128-2047		Invalid.					
2048		Forcible stop.					

Example: If segment signal 3 is written, segment program 3 is triggered.

P5.20*	Data size	16bit	Data format		DEC		
	Modbus address	2040, 2041	CANopen address		0x2514, 0x00		

P5.21	Target speed 00	Setting range	Default	Unit	Applicable mode		
		0–6000	20	r/min	P		
P5.22	Target speed 01	Setting range	Default	Unit	Applicable mode		
		0–6000	50	r/min	P		
P5.23	Target speed 02	Setting range	Default	Unit	Applicable mode		
		0–6000	100	r/min	P		
P5.24	Target speed 03	Setting range	Default	Unit	Applicable mode		
		0–6000	200	r/min	P		
P5.25	Target speed 04	Setting range	Default	Unit	Applicable mode		

		0-6000	300	r/min	P		
P5.26	Target speed 05	Setting range	Default	Unit	Applicable mode		
		0-6000	500	r/min	P		
P5.27	Target speed 06	Setting range	Default	Unit	Applicable mode		
		0-6000	600	r/min	P		
P5.28	Target speed 07	Setting range	Default	Unit	Applicable mode		
		0-6000	800	r/min	P		
P5.29	Target speed 08	Setting range	Default	Unit	Applicable mode		
		0-6000	1000	r/min	P		
P5.30	Target speed 09	Setting range	Default	Unit	Applicable mode		
		0-6000	1300	r/min	P		
P5.31	Target speed 10	Setting range	Default	Unit	Applicable mode		
		0-6000	1500	r/min	P		
P5.32	Target speed 11	Setting range	Default	Unit	Applicable mode		
		0-6000	1800	r/min	P		
P5.33	Target speed 12	Setting range	Default	Unit	Applicable mode		
		0-6000	2000	r/min	P		
P5.34	Target speed 13	Setting range	Default	Unit	Applicable mode		
		0-6000	2300	r/min	P		
P5.35	Target speed 14	Setting range	Default	Unit	Applicable mode		
		0-6000	2500	r/min	P		
P5.36	Target speed 15	Setting range	Default	Unit	Applicable mode		
		0-6000	3000	r/min	P		
This group of parameter specifies the target speed for each segment.							
P5.21	Data size		16bit	Data format		DEC	
	Modbus address		2042, 2043	CANopen address		0x2515, 0x00	

P5.22	Data size	16bit	Data format	DEC
	Modbus address	2044, 2045	CANopen address	0x2516, 0x00
P5.23	Data size	16bit	Data format	DEC
	Modbus address	2046, 2047	CANopen address	0x2517, 0x00
P5.24	Data size	16bit	Data format	DEC
	Modbus address	2048, 2049	CANopen address	0x2518, 0x00
P5.25	Data size	16bit	Data format	DEC
	Modbus address	2050, 2051	CANopen address	0x2519, 0x00
P5.26	Data size	16bit	Data format	DEC
	Modbus address	2052, 2053	CANopen address	0x251A, 0x00
P5.27	Data size	16bit	Data format	DEC
	Modbus address	2054, 2055	CANopen address	0x251B, 0x00
P5.28	Data size	16bit	Data format	DEC
	Modbus address	2056, 2057	CANopen address	0x251C, 0x00
P5.29	Data size	16bit	Data format	DEC
	Modbus address	2058, 2059	CANopen address	0x251D, 0x00
P5.30	Data size	16bit	Data format	DEC
	Modbus address	2060, 2061	CANopen address	0x251E, 0x00
P5.31	Data size	16bit	Data format	DEC
	Modbus address	2062, 2063	CANopen address	0x251F, 0x00
P5.32	Data size	16bit	Data format	DEC
	Modbus address	2064, 2065	CANopen address	0x2520, 0x00
P5.33	Data size	16bit	Data format	DEC
	Modbus address	2066, 2067	CANopen address	0x2521, 0x00
P5.34	Data size	16bit	Data format	DEC
	Modbus address	2068, 2069	CANopen address	0x2522, 0x00
P5.35	Data size	16bit	Data format	DEC
	Modbus address	2070, 2071	CANopen address	0x2523, 0x00
P5.36	Data size	16bit	Data format	DEC
	Modbus address	2072, 2073	CANopen address	0x2524, 0x00

P5.37	ACC/DEC time 00	Setting range	Default	Unit	Applicable mode		
		0-32767	200	ms	P		
P5.38	ACC/DEC time 01	Setting range	Default	Unit	Applicable mode		
		0-32767	300	ms	P		

P5.39	ACC/DEC time 02	Setting range	Default	Unit	Applicable mode		
		0-32767	500	ms	P		
P5.40	ACC/DEC time 03	Setting range	Default	Unit	Applicable mode		
		0-32767	600	ms	P		
P5.41	ACC/DEC time 04	Setting range	Default	Unit	Applicable mode		
		0-32767	800	ms	P		
P5.42	ACC/DEC time 05	Setting range	Default	Unit	Applicable mode		
		0-32767	900	ms	P		
P5.43	ACC/DEC time 06	Setting range	Default	Unit	Applicable mode		
		0-32767	1000	ms	P		
P5.44	ACC/DEC time 07	Setting range	Default	Unit	Applicable mode		
		0-32767	1200	ms	P		
P5.45	ACC/DEC time 08	Setting range	Default	Unit	Applicable mode		
		0-32767	1500	ms	P		
P5.46	ACC/DEC time 09	Setting range	Default	Unit	Applicable mode		
		0-32767	2000	ms	P		
P5.47	ACC/DEC time 10	Setting range	Default	Unit	Applicable mode		
		0-32767	2500	ms	P		
P5.48	ACC/DEC time 11	Setting range	Default	Unit	Applicable mode		
		0-32767	3000	ms	P		
P5.49	ACC/DEC time 12	Setting range	Default	Unit	Applicable mode		
		0-32767	5000	ms	P		
P5.50	ACC/DEC time 13	Setting range	Default	Unit	Applicable mode		
		0-32767	8000	ms	P		

P5.51	ACC/DEC time 14	Setting range	Default	Unit	Applicable mode		
		0–32767	50	ms	P		
P5.52	ACC/DEC time 15	Setting range	Default	Unit	Applicable mode		
		0–32767	30	ms	P		
This group of parameter specifies the acceleration or deceleration time for each segment.							
P5.37	Data size	16bit	Data format	DEC			
	Modbus address	2074, 2075	CANopen address	0x2525, 0x00			
P5.38	Data size	16bit	Data format	DEC			
	Modbus address	2076, 2077	CANopen address	0x2526, 0x00			
P5.39	Data size	16bit	Data format	DEC			
	Modbus address	2078, 2079	CANopen address	0x2527, 0x00			
P5.40	Data size	16bit	Data format	DEC			
	Modbus address	2080, 2081	CANopen address	0x2528, 0x00			
P5.41	Data size	16bit	Data format	DEC			
	Modbus address	2082, 2083	CANopen address	0x2529, 0x00			
P5.42	Data size	16bit	Data format	DEC			
	Modbus address	2084, 2085	CANopen address	0x252A, 0x00			
P5.43	Data size	16bit	Data format	DEC			
	Modbus address	2086, 2087	CANopen address	0x252B, 0x00			
P5.44	Data size	16bit	Data format	DEC			
	Modbus address	2088, 2089	CANopen address	0x252C, 0x00			
P5.45	Data size	16bit	Data format	DEC			
	Modbus address	2090, 2091	CANopen address	0x252D, 0x00			
P5.46	Data size	16bit	Data format	DEC			
	Modbus address	2092, 2093	CANopen address	0x252E, 0x00			
P5.47	Data size	16bit	Data format	DEC			
	Modbus address	2094, 2095	CANopen address	0x252F, 0x00			
P5.48	Data size	16bit	Data format	DEC			
	Modbus address	2096, 2097	CANopen address	0x2530, 0x00			
P5.49	Data size	16bit	Data format	DEC			
	Modbus address	2098, 2099	CANopen address	0x2531, 0x00			
P5.50	Data size	16bit	Data format	DEC			
	Modbus address	2100, 2101	CANopen address	0x2532, 0x00			
P5.51	Data size	16bit	Data format	DEC			

	Modbus address	2102, 2103	CANopen address	0x2533, 0x00
P5.52	Data size	16bit	Data format	DEC
	Modbus address	2104, 2105	CANopen address	0x2534, 0x00

		Setting range	Default	Unit	Applicable mode
P5.53	Delay time 00	Setting range	Default	Unit	Applicable mode
		0-32767	0	ms	P
P5.54	Delay time 01	Setting range	Default	Unit	Applicable mode
		0-32767	100	ms	P
P5.55	Delay time 02	Setting range	Default	Unit	Applicable mode
		0-32767	200	ms	P
P5.56	Delay time 03	Setting range	Default	Unit	Applicable mode
		0-32767	400	ms	P
P5.57	Delay time 04	Setting range	Default	Unit	Applicable mode
		0-32767	500	ms	P
P5.58	Delay time 05	Setting range	Default	Unit	Applicable mode
		0-32767	800	ms	P
P5.59	Delay time 06	Setting range	Default	Unit	Applicable mode
		0-32767	1000	ms	P
P5.60	Delay time 07	Setting range	Default	Unit	Applicable mode
		0-32767	1500	ms	P
P5.61	Delay time 08	Setting range	Default	Unit	Applicable mode
		0-32767	2000	ms	P
P5.62	Delay time 09	Setting range	Default	Unit	Applicable mode
		0-32767	2500	ms	P
P5.63	Delay time 10	Setting range	Default	Unit	Applicable mode
		0-32767	3000	ms	P

P5.64	Delay time 11	Setting range	Default	Unit	Applicable mode		
		0-32767	3500	ms	P		
P5.65	Delay time 12	Setting range	Default	Unit	Applicable mode		
		0-32767	4000	ms	P		
P5.66	Delay time 13	Setting range	Default	Unit	Applicable mode		
		0-32767	4500	ms	P		
P5.67	Delay time 14	Setting range	Default	Unit	Applicable mode		
		0-32767	5000	ms	P		
P5.68	Delay time 15	Setting range	Default	Unit	Applicable mode		
		0-32767	5500	ms	P		

This group of parameter specifies the delay time for each segment.

P5.53	Data size	16bit	Data format	DEC
	Modbus address	2106, 2107	CANopen address	0x2535, 0x00
P5.54	Data size	16bit	Data format	DEC
	Modbus address	2108, 2109	CANopen address	0x2536, 0x00
P5.55	Data size	16bit	Data format	DEC
	Modbus address	2110, 2111	CANopen address	0x2537, 0x00
P5.56	Data size	16bit	Data format	DEC
	Modbus address	2112, 2113	CANopen address	0x2538, 0x00
P5.57	Data size	16bit	Data format	DEC
	Modbus address	2114, 2115	CANopen address	0x2539, 0x00
P5.58	Data size	16bit	Data format	DEC
	Modbus address	2116, 2117	CANopen address	0x253A, 0x00
P5.59	Data size	16bit	Data format	DEC
	Modbus address	2118, 2119	CANopen address	0x253B, 0x00
P5.60	Data size	16bit	Data format	DEC
	Modbus address	2120, 2121	CANopen address	0x253C, 0x00
P5.61	Data size	16bit	Data format	DEC
	Modbus address	2122, 2123	CANopen address	0x253D, 0x00
P5.62	Data size	16bit	Data format	DEC
	Modbus address	2124, 2125	CANopen address	0x253E, 0x00
P5.63	Data size	16bit	Data format	DEC

	Modbus address	2126, 2127	CANopen address	0x253F, 0x00
P5.64	Data size	16bit	Data format	DEC
	Modbus address	2128, 2129	CANopen address	0x2540, 0x00
P5.65	Data size	16bit	Data format	DEC
	Modbus address	2130, 2131	CANopen address	0x2541, 0x00
P5.66	Data size	16bit	Data format	DEC
	Modbus address	2132, 2133	CANopen address	0x2542, 0x00
P5.67	Data size	16bit	Data format	DEC
	Modbus address	2134, 2135	CANopen address	0x2543, 0x00
P5.68	Data size	16bit	Data format	DEC
	Modbus address	2136, 2137	CANopen address	0x2544, 0x00

P5.69	PTP control buffer switch	Setting range	Default	Unit	Applicable mode		
		0-1	1	-	P		
If buffering is enabled for PTP control, eight buffers can be received successively and executed sequentially.							
P5.69	Data size	16bit	Data format	DEC			
	Modbus address	2138, 2139	CANopen address	0x2545, 0x00			

P5.70	Disk single-turn resolution	Setting range	Default	Unit	Applicable mode		
		$-(2^{31}-1)-(2^{31}-1)$	10000	pulse	P		
This parameter specifies the single-turn resolution of the disk that the motor drives.							
P5.70	Data size	32bit	Data format	DEC			
	Modbus address	2140, 2141	CANopen address	0x2546, 0x00			

P5.71	Disk homing switch	Setting range	Default	Unit	Applicable mode		
		0-3	0	-	P		
This parameter specifies the homing mode of the disk.							
P5.71	Data size	16bit	Data format	DEC			
	Modbus address	2142, 2143	CANopen address	0x2547, 0x00			

P5.72	Super multiturn mode	Setting range	Default	Unit	Applicable mode		
		0-1	0	-	P		

If the super multiturn mode is used, the turn counting number of the multiturn encoder changes from 16 bits to 32 bits, while the multiturn encoder counts a total of 2^{16} turns in most cases.

P5.72	Data size	16bit	Data format	DEC
	Modbus address	2144, 2145	CANopen address	0x2548, 0x00

P5.73	Digital trigger mode for PTP control	Setting range	Default	Unit	Applicable mode	
		0-1	0	-	P	
		Setting	Meaning			
		[0]	Binary input + Terminal trigger mode			
		1	Single terminal trigger mode (supporting 7 PTPs only)			
P5.73	Data size	16bit	Data format	DEC		
	Modbus address	2146, 2147	CANopen address	0x2549, 0x00		

P5.74	Digital output mode for PTP control	Setting range	Default	Unit	Applicable mode	
		0-4	0	-	P	
		Setting	Meaning			
		[0]	Output before PTP arrival			
		1	Output after PTP arrival			
		2	Single-point output + Output before PTP arrival			
		3	Single-point output + Output after PTP arrival			
		4	Single-point output + Output after PTP arrival (only the control word in the absolute position supported)			
P5.74	Data size	16bit	Data format	DEC		
	Modbus address	2148, 2149	CANopen address	0x254A, 0x00		

P5.75	Suspend PTP control	Setting range	Default	Unit	Applicable mode	
		0-1	0	-	P	
This parameter specifies whether to suspend PTP control. The value 1 indicates PTP control is suspended.						
P5.75	Data size	16bit	Data format	DEC		
	Modbus address	2150, 2151	CANopen address	0x254B, 0x00		

6.7 Application functions (group P6)

P6.00	Forward low jogging speed	Setting range	Default	Unit	Applicable mode		
		0-6000	5	r/min	P		
This parameter specifies the speed of slow forward jogging, which is triggered by the forward jogging terminal and high-low jogging speed switching terminal.							
P6.00	Data size	16bit	Data format		DEC		
	Modbus address	2200, 2201	CANopen address		0x2600, 0x00		

P6.01	Reverse low jogging speed	Setting range	Default	Unit	Applicable mode		
		-6000-0	-5	r/min	P		
This parameter specifies the speed of slow reverse jogging, which is triggered by the reverse jogging terminal and high-low jogging speed switching terminal.							
P6.01	Data size	16bit	Data format		DEC		
	Modbus address	2202, 2203	CANopen address		0x2601, 0x00		

P6.02 ¹	Data latching switch	Setting range	Default	Unit	Applicable mode		
		0-1	0	-	P		
This parameter specifies whether to enable the data latching switch. If the switch is enabled, the position information is written to the EEPROM each time the terminal is latched. However, frequent latching may cause EEPROM damage.							
		Setting	Meaning				
		[0]	Disable				
		1	Enable				
P6.02 ¹	Data size	16bit	Data format		DEC		
	Modbus address	2204, 2205	CANopen address		0x2602, 0x00		

P6.03	Save position latching	Setting range	Default	Unit	Applicable mode		
		0-1	0	-	P		
This parameter specifies whether to save position latching.							
		Setting	Meaning				
		[0]	Not save				
		1	Save				
P6.03	Data size	16bit	Data format		DEC		
	Modbus address	2206, 2207	CANopen address		0x2603, 0x00		

P6.04	Forward high jogging speed	Setting range	Default	Unit	Applicable mode		
		0–6000	60	r/min	P		
This parameter specifies the speed of fast forward jogging, which is triggered by the forward jogging terminal and high-low jogging speed switching terminal.							
P6.04	Data size	16bit	Data format	DEC			
	Modbus address	2208, 2209	CANopen address	0x2604, 0x00			

P6.05	Reverse high jogging speed	Setting range	Default	Unit	Applicable mode		
		-6000–0	-60	r/min	P		
This parameter specifies the speed of fast reverse jogging, which is triggered by the reverse jogging terminal and high-low jogging speed switching terminal.							
P6.05	Data size	16bit	Data format	DEC			
	Modbus address	2210, 2211	CANopen address	0x2605, 0x00			

P6.06	Enable terminal jogging	Setting range	Default	Unit	Applicable mode		
		0–1	0	-	P		
This parameter specifies whether to enable terminal jogging.							
		Setting	Meaning				
		[0]	Disable				
		1	Enable				
P6.06	Data size	16bit	Data format	DEC			
	Modbus address	2212, 2213	CANopen address	0x2606, 0x00			

P6.20 ¹	Turret switch	Setting range	Default	Unit	Applicable mode		
		0–1	0	-	P		
This parameter specifies whether to enable the turret switch.							
		Setting	Meaning				
		[0]	Disable				
		1	Enable				
P6.20 ¹	Data size	16bit	Data format	DEC			
	Modbus address	2240, 2241	CANopen address	0x2614, 0x00			

P6.21	Knives per turret	Setting range	Default	Unit	Applicable mode		
		1–128	16	-	P		
This parameter specifies the number of knives in a turret.							
P6.21	Data size		16bit	Data format		DEC	
	Modbus address		2242, 2243	CANopen address		0x2615, 0x00	
P6.22	Pulses per turret rotation	Setting range	Default	Unit	Applicable mode		
		$2-(2^{31}-1)$	10000	reference unit	P		
This parameter specifies the number of pulses needed for each turret rotation.							
P6.22	Data size		32bit	Data format		DEC	
	Modbus address		2244, 2245	CANopen address		0x2616, 0x00	
P6.23 ¹	Turret start point	Setting range	Default	Unit	Applicable mode		
		$-(2^{31}-1)-(2^{31}-1)$	0	reference unit	P		
This parameter specifies the start point for a turret.							
P6.23 ¹	Data size		32bit	Data format		DEC	
	Modbus address		2246, 2247	CANopen address		0x2617, 0x00	
P6.30 ¹	Gantry synchronization switch	Setting range	Default	Unit	Applicable mode		
		0–1	0	-	P		
This parameter specifies whether to enable the gantry synchronization switch.							
		Setting	Meaning				
		[0]	Disable				
		1	Enable				
P6.30 ¹	Data size		16bit	Data format		DEC	
	Modbus address		2260, 2261	CANopen address		0x261E, 0x00	
P6.31	Speed control gain for gantry synchronization	Setting range	Default	Unit	Applicable mode		
		0.0–3276.7	0.0	Hz	P		
This parameter specifies the speed control gain for gantry synchronization.							
P6.31	Data size		16bit	Data format		DEC	
	Modbus address		2262, 2263	CANopen address		0x261F, 0x00	

P6.32	Speed control integral for gantry synchronization	Setting range	Default	Unit	Applicable mode		
		0.1–1000.0	1000.0	ms	P		
This parameter specifies the time constant of the speed control integral for gantry synchronization. The value 1000 indicates that the integral function is invalid.							
P6.32	Data size	16bit	Data format		DEC		
	Modbus address	2264, 2265	CANopen address		0x2620, 0x00		

P6.33	Position control gain for gantry synchronization	Setting range	Default	Unit	Applicable mode		
		0.0–3276.7	1000.0	Hz	P		
This parameter specifies the position control gain for gantry synchronization.							
P6.33	Data size	16bit	Data format		DEC		
	Modbus address	2266, 2267	CANopen address		0x2621, 0x00		

P6.34	Torque filter for gantry synchronization compensation	Setting range	Default	Unit	Applicable mode		
		0.00–64.00	0.00	ms	P		
This parameter specifies the torque filter time constant for gantry synchronization compensation.							
P6.34	Data size	16bit	Data format		DEC		
	Modbus address	2268, 2269	CANopen address		0x2622, 0x00		

P6.35	Speed filter for gantry synchronization compensation	Setting range	Default	Unit	Applicable mode		
		0.00–64.00	0.00	ms	P		
This parameter specifies the speed filter time constant for gantry synchronization compensation.							
P6.35	Data size	16bit	Data format		DEC		
	Modbus address	2270, 2271	CANopen address		0x2623, 0x00		

P6.36	Bandwidth ratio for gantry synchronization control	Setting range	Default	Unit	Applicable mode		
		0.0–1000.0	0.0	%	P		
This parameter specifies the bandwidth ratio for gantry synchronization control.							

Bandwidth ratio = Servo bandwidth/(Servo bandwidth + Synchronization bandwidth)				
P6.36	Data size	16bit	Data format	DEC
	Modbus address	2272, 2273	CANopen address	0x2624, 0x00

P6.37 ¹	Master/slave node for gantry synchronization	Setting range	Default	Unit	Applicable mode		
		0–1	0	-	P		

This parameter specifies the master or slave node for gantry synchronization.

Setting	Meaning
[0]	Slave node
1	Master node

P6.37 ¹	Data size	16bit	Data format	DEC
	Modbus address	2274, 2275	CANopen address	0x2625, 0x00

P6.38	Retreat distance for gantry synchronization alignment	Setting range	Default	Unit	Applicable mode		
		$-(2^{31}-2)-(2^{31}-2)$	10000	reference unit	P		

This parameter specifies the distance that the servo retreats after contacting the two alignment sensors.

P6.38	Data size	32bit	Data format	DEC
	Modbus address	2276, 2277	CANopen address	0x2626, 0x00

P6.39	Retreat speed for gantry synchronization alignment	Setting range	Default	Unit	Applicable mode		
		1–200	60	r/min	P		

This parameter specifies the speed at which the servo retreats after contacting the two alignment sensors.

P6.39	Data size	16bit	Data format	DEC
	Modbus address	2278, 2279	CANopen address	0x2627, 0x00

P6.40	Approaching speed for gantry synchronization alignment	Setting range	Default	Unit	Applicable mode		
		1–60	5	r/min	P		

This parameter specifies the speed at which the servo approaches the alignment sensors again after contacting the sensors.

P6.40	Data size	16bit	Data format	DEC
	Modbus address	2280, 2281	CANopen address	0x2628, 0x00

P6.41	Gantry alignment direction	Setting range	Default	Unit	Applicable mode	
		0–1	0	-	P	

This parameter specifies the gantry alignment direction.

Setting	Meaning
[0]	Forward
1	Reverse

P6.41	Data size	16bit	Data format	DEC
	Modbus address	2282, 2283	CANopen address	0x2629, 0x00

6.8 PTP control (groups PtP0, PtP1, and PtP2)

PtP0.00	Control word of segment 00	Setting range	Default	Unit	Applicable mode	
		0–0x7FFFFFFF	0x00000000	-	P	

General description

Data bit	Name	Function
Bit0–3	MODE	PTP running mode.
Bit4–7	OPT	PTP attribute.
Bit8–11	ACC	ACC/DEC time index.
Bit12–15	SPD	Target speed index.
Bit16–19	DLY	Delay time index.
Bit20–23	CYL	Number of cycles for executing the current segment.
Bit24–30	JMP	The program jumps to the next segment.

Description for MODE

Setting	Meaning
0	The program stops after the current segment is executed.
1	The program jumps to the next segment after the current segment is executed.
2	The program stops after circular execution. If CMD is 1, the circulation is invalid.
3	The program jumps to the next segment after circular execution. If CMD is 1, the circulation is invalid.

Description for OPT

Data bit	Name	Function
Bit4	INS	Insertion. The current segment can suspend segments that are

		being executed or not executed.
Bit5	OVLP	Overlap. The current segment and next segment can overlap and then be executed.
Bit6-7	CMD	Position command type: 0 indicates incremental position while 1 indicates absolute position.

Description for INS

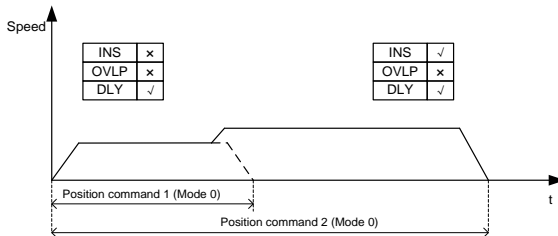
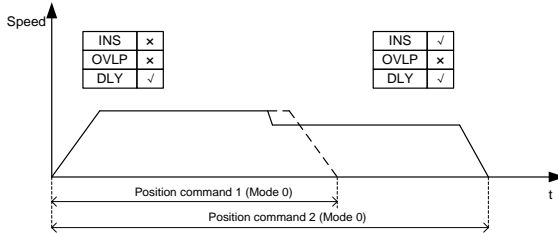

Description for OVLP

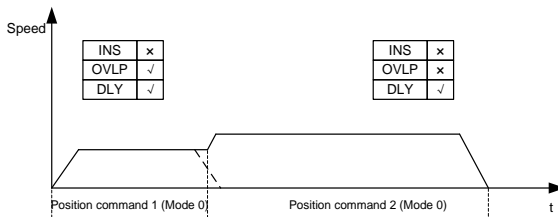
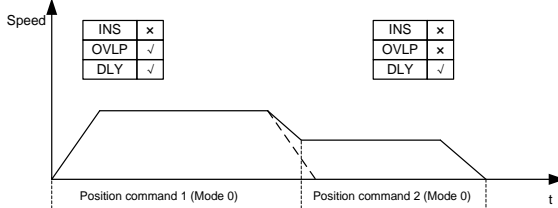

Relationship between INS and OVLP

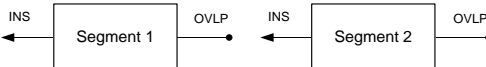

Note:

- INS indicates the current segment has execution priority over the previous one, while OVLP indicates the current segment is executed after the overlap with the next one is checked.
- INS takes priority over OVLP. For example, if both OVLP for segment 1 and INS for segment 2 are enabled, OVLP for segment 1 is invalid.
- The two segments in the reverse directions cannot overlap.

PtP0.00	Data size	32bit	Data format	HEX
	Modbus address	3200, 3201	CANopen address	0x2B00, 0x00

PtP0.01	Position of segment 00	Setting range	Default t	Unit	Applicable mode	
		$-(2^{31}-1)-(2^{31}-1)$	0	reference unit	P	

This parameter specifies the position of segment 00. The CMD attribute determines the command mode of this PTP position. P0.37 is inapplicable to this PTP position.

PtP0.01	Data size	32bit	Data format	DEC
	Modbus address	3202, 3203	CANopen address	0x2B01, 0x00

PtP0.02	Control word of segment 01	Setting range	Default	Unit	Applicable mode	
		0-0x7FFFFFFF	0x00000000	-	P	
PtP0.04	Control word of segment 02	Setting range	Default	Unit	Applicable mode	
		0-0x7FFFFFFF	0x00000000	-	P	
PtP0.06	Control word of segment 03	Setting range	Default	Unit	Applicable mode	
		0-0x7FFFFFFF	0x00000000	-	P	
PtP0.08	Control word of segment 04	Setting range	Default	Unit	Applicable mode	
		0-0x7FFFFFFF	0x00000000	-	P	
PtP0.10	Control word of segment 05	Setting range	Default	Unit	Applicable mode	
		0-0x7FFFFFFF	0x00000000	-	P	
PtP0.12	Control word of segment 06	Setting range	Default	Unit	Applicable mode	
		0-0x7FFFFFFF	0x00000000	-	P	
PtP0.14	Control word of segment 07	Setting range	Default	Unit	Applicable mode	
		0-0x7FFFFFFF	0x00000000	-	P	

PtP0.16	Control word of segment 08	Setting range	Default	Unit	Applicable mode		
		0-0x7FFFFFFF	0x00000000	-	P		
PtP0.18	Control word of segment 09	Setting range	Default	Unit	Applicable mode		
		0-0x7FFFFFFF	0x00000000	-	P		
PtP0.20	Control word of segment 10	Setting range	Default	Unit	Applicable mode		
		0-0x7FFFFFFF	0x00000000	-	P		
PtP0.22	Control word of segment 11	Setting range	Default	Unit	Applicable mode		
		0-0x7FFFFFFF	0x00000000	-	P		
PtP0.24	Control word of segment 12	Setting range	Default	Unit	Applicable mode		
		0-0x7FFFFFFF	0x00000000	-	P		
PtP0.26	Control word of segment 13	Setting range	Default	Unit	Applicable mode		
		0-0x7FFFFFFF	0x00000000	-	P		
PtP0.28	Control word of segment 14	Setting range	Default	Unit	Applicable mode		
		0-0x7FFFFFFF	0x00000000	-	P		
PtP0.30	Control word of segment 15	Setting range	Default	Unit	Applicable mode		
		0-0x7FFFFFFF	0x00000000	-	P		
PtP0.32	Control word of segment 16	Setting range	Default	Unit	Applicable mode		
		0-0x7FFFFFFF	0x00000000	-	P		
PtP0.34	Control word of segment 17	Setting range	Default	Unit	Applicable mode		
		0-0x7FFFFFFF	0x00000000	-	P		
PtP0.36	Control word of segment 18	Setting range	Default	Unit	Applicable mode		
		0-0x7FFFFFFF	0x00000000	-	P		
PtP0.38	Control word of segment 19	Setting range	Default	Unit	Applicable mode		
		0-0x7FFFFFFF	0x00000000	-	P		

PtP0.40	Control word of segment 20	Setting range	Default	Unit	Applicable mode		
		0-0x7FFFFFFF	0x00000000	-	P		
PtP0.42	Control word of segment 21	Setting range	Default	Unit	Applicable mode		
		0-0x7FFFFFFF	0x00000000	-	P		
PtP0.44	Control word of segment 22	Setting range	Default	Unit	Applicable mode		
		0-0x7FFFFFFF	0x00000000	-	P		
PtP0.46	Control word of segment 23	Setting range	Default	Unit	Applicable mode		
		0-0x7FFFFFFF	0x00000000	-	P		
PtP0.48	Control word of segment 24	Setting range	Default	Unit	Applicable mode		
		0-0x7FFFFFFF	0x00000000	-	P		
PtP0.50	Control word of segment 25	Setting range	Default	Unit	Applicable mode		
		0-0x7FFFFFFF	0x00000000	-	P		
PtP0.52	Control word of segment 26	Setting range	Default	Unit	Applicable mode		
		0-0x7FFFFFFF	0x00000000	-	P		
PtP0.54	Control word of segment 27	Setting range	Default	Unit	Applicable mode		
		0-0x7FFFFFFF	0x00000000	-	P		
PtP0.56	Control word of segment 28	Setting range	Default	Unit	Applicable mode		
		0-0x7FFFFFFF	0x00000000	-	P		
PtP0.58	Control word of segment 29	Setting range	Default	Unit	Applicable mode		
		0-0x7FFFFFFF	0x00000000	-	P		
PtP0.60	Control word of segment 30	Setting range	Default	Unit	Applicable mode		
		0-0x7FFFFFFF	0x00000000	-	P		
PtP0.62	Control word of segment 31	Setting range	Default	Unit	Applicable mode		
		0-0x7FFFFFFF	0x00000000	-	P		

PtP0.64	Control word of segment 32	Setting range	Default	Unit	Applicable mode		
		0-0x7FFFFFFF	0x00000000	-	P		
PtP0.66	Control word of segment 33	Setting range	Default	Unit	Applicable mode		
		0-0x7FFFFFFF	0x00000000	-	P		
PtP0.68	Control word of segment 34	Setting range	Default	Unit	Applicable mode		
		0-0x7FFFFFFF	0x00000000	-	P		
PtP0.70	Control word of segment 35	Setting range	Default	Unit	Applicable mode		
		0-0x7FFFFFFF	0x00000000	-	P		
PtP0.72	Control word of segment 36	Setting range	Default	Unit	Applicable mode		
		0-0x7FFFFFFF	0x00000000	-	P		
PtP0.74	Control word of segment 37	Setting range	Default	Unit	Applicable mode		
		0-0x7FFFFFFF	0x00000000	-	P		
PtP0.76	Control word of segment 38	Setting range	Default	Unit	Applicable mode		
		0-0x7FFFFFFF	0x00000000	-	P		
PtP0.78	Control word of segment 39	Setting range	Default	Unit	Applicable mode		
		0-0x7FFFFFFF	0x00000000	-	P		
PtP0.80	Control word of segment 40	Setting range	Default	Unit	Applicable mode		
		0-0x7FFFFFFF	0x00000000	-	P		
PtP0.82	Control word of segment 41	Setting range	Default	Unit	Applicable mode		
		0-0x7FFFFFFF	0x00000000	-	P		
PtP0.84	Control word of segment 42	Setting range	Default	Unit	Applicable mode		
		0-0x7FFFFFFF	0x00000000	-	P		
PtP0.86	Control word of segment 43	Setting range	Default	Unit	Applicable mode		
		0-0x7FFFFFFF	0x00000000	-	P		

PtP0.88	Control word of segment 44	Setting range	Default	Unit	Applicable mode		
		0-0x7FFFFFFF	0x00000000	-	P		
PtP0.90	Control word of segment 45	Setting range	Default	Unit	Applicable mode		
		0-0x7FFFFFFF	0x00000000	-	P		
PtP0.92	Control word of segment 46	Setting range	Default	Unit	Applicable mode		
		0-0x7FFFFFFF	0x00000000	-	P		
PtP0.94	Control word of segment 47	Setting range	Default	Unit	Applicable mode		
		0-0x7FFFFFFF	0x00000000	-	P		
PtP0.96	Control word of segment 48	Setting range	Default	Unit	Applicable mode		
		0-0x7FFFFFFF	0x00000000	-	P		
PtP0.98	Control word of segment 49	Setting range	Default	Unit	Applicable mode		
		0-0x7FFFFFFF	0x00000000	-	P		

This group of parameter specifies the control words of segments 01 to 49. For details, see the description for PtP0.00.

PtP0.02	Data size	32bit	Data format	HEX
	Modbus address	3204, 3205	CANopen address	0x2B02, 0x00
PtP0.04	Data size	32bit	Data format	HEX
	Modbus address	3208, 3209	CANopen address	0x2B04, 0x00
PtP0.06	Data size	32bit	Data format	HEX
	Modbus address	3212, 3213	CANopen address	0x2B06, 0x00
PtP0.08	Data size	32bit	Data format	HEX
	Modbus address	3216, 3217	CANopen address	0x2B08, 0x00
PtP0.10	Data size	32bit	Data format	HEX
	Modbus address	3220, 3221	CANopen address	0x2B0A, 0x00
PtP0.12	Data size	32bit	Data format	HEX
	Modbus address	3224, 3225	CANopen address	0x2B0C, 0x00
PtP0.14	Data size	32bit	Data format	HEX
	Modbus address	3228, 3229	CANopen address	0x2B0E, 0x00
PtP0.16	Data size	32bit	Data format	HEX
	Modbus address	3232, 3233	CANopen address	0x2B10, 0x00
PtP0.18	Data size	32bit	Data format	HEX

	Modbus address	3236, 3237	CANopen address	0x2B12, 0x00
PtP0.20	Data size	32bit	Data format	HEX
	Modbus address	3240, 3241	CANopen address	0x2B14, 0x00
PtP0.22	Data size	32bit	Data format	HEX
	Modbus address	3244, 3245	CANopen address	0x2B16, 0x00
PtP0.24	Data size	32bit	Data format	HEX
	Modbus address	3248, 3249	CANopen address	0x2B18, 0x00
PtP0.26	Data size	32bit	Data format	HEX
	Modbus address	3252, 3253	CANopen address	0x2B1A, 0x00
PtP0.28	Data size	32bit	Data format	HEX
	Modbus address	3256, 3257	CANopen address	0x2B1C, 0x00
PtP0.30	Data size	32bit	Data format	HEX
	Modbus address	3260, 3261	CANopen address	0x2B1E, 0x00
PtP0.32	Data size	32bit	Data format	HEX
	Modbus address	3264, 3265	CANopen address	0x2B20, 0x00
PtP0.34	Data size	32bit	Data format	HEX
	Modbus address	3268, 3269	CANopen address	0x2B22, 0x00
PtP0.36	Data size	32bit	Data format	HEX
	Modbus address	3272, 3273	CANopen address	0x2B24, 0x00
PtP0.38	Data size	32bit	Data format	HEX
	Modbus address	3276, 3277	CANopen address	0x2B26, 0x00
PtP0.40	Data size	32bit	Data format	HEX
	Modbus address	3280, 3281	CANopen address	0x2B28, 0x00
PtP0.42	Data size	32bit	Data format	HEX
	Modbus address	3284, 3285	CANopen address	0x2B2A, 0x00
PtP0.44	Data size	32bit	Data format	HEX
	Modbus address	3288, 3289	CANopen address	0x2B2C, 0x00
PtP0.46	Data size	32bit	Data format	HEX
	Modbus address	3292, 3293	CANopen address	0x2B2E, 0x00
PtP0.48	Data size	32bit	Data format	HEX
	Modbus address	3296, 3297	CANopen address	0x2B30, 0x00
PtP0.50	Data size	32bit	Data format	HEX
	Modbus address	3300, 3301	CANopen address	0x2B32, 0x00
PtP0.52	Data size	32bit	Data format	HEX
	Modbus address	3304, 3305	CANopen address	0x2B34, 0x00
PtP0.54	Data size	32bit	Data format	HEX
	Modbus address	3308, 3309	CANopen address	0x2B36, 0x00

PtP0.56	Data size	32bit	Data format	HEX
	Modbus address	3312, 3313	CANopen address	0x2B38, 0x00
PtP0.58	Data size	32bit	Data format	HEX
	Modbus address	3316, 3317	CANopen address	0x2B3A, 0x00
PtP0.60	Data size	32bit	Data format	HEX
	Modbus address	3320, 3321	CANopen address	0x2B3C, 0x00
PtP0.62	Data size	32bit	Data format	HEX
	Modbus address	3324, 3325	CANopen address	0x2B3E, 0x00
PtP0.64	Data size	32bit	Data format	HEX
	Modbus address	3328, 3329	CANopen address	0x2B40, 0x00
PtP0.66	Data size	32bit	Data format	HEX
	Modbus address	3332, 3333	CANopen address	0x2B42, 0x00
PtP0.68	Data size	32bit	Data format	HEX
	Modbus address	3336, 3337	CANopen address	0x2B44, 0x00
PtP0.70	Data size	32bit	Data format	HEX
	Modbus address	3340, 3341	CANopen address	0x2B46, 0x00
PtP0.72	Data size	32bit	Data format	HEX
	Modbus address	3344, 3345	CANopen address	0x2B48, 0x00
PtP0.74	Data size	32bit	Data format	HEX
	Modbus address	3348, 3349	CANopen address	0x2B4A, 0x00
PtP0.76	Data size	32bit	Data format	HEX
	Modbus address	3352, 3353	CANopen address	0x2B4C, 0x00
PtP0.78	Data size	32bit	Data format	HEX
	Modbus address	3356, 3357	CANopen address	0x2B4E, 0x00
PtP0.80	Data size	32bit	Data format	HEX
	Modbus address	3360, 3361	CANopen address	0x2B50, 0x00
PtP0.82	Data size	32bit	Data format	HEX
	Modbus address	3364, 3365	CANopen address	0x2B52, 0x00
PtP0.84	Data size	32bit	Data format	HEX
	Modbus address	3368, 3369	CANopen address	0x2B54, 0x00
PtP0.86	Data size	32bit	Data format	HEX
	Modbus address	3372, 3373	CANopen address	0x2B56, 0x00
PtP0.88	Data size	32bit	Data format	HEX
	Modbus address	3376, 3377	CANopen address	0x2B58, 0x00
PtP0.90	Data size	32bit	Data format	HEX
	Modbus address	3380, 3381	CANopen address	0x2B5A, 0x00
PtP0.92	Data size	32bit	Data format	HEX

	Modbus address	3384, 3385	CANopen address	0x2B5C, 0x00
PtP0.94	Data size	32bit	Data format	HEX
	Modbus address	3388, 3389	CANopen address	0x2B5E, 0x00
PtP0.96	Data size	32bit	Data format	HEX
	Modbus address	3392, 3393	CANopen address	0x2B60, 0x00
PtP0.98	Data size	32bit	Data format	HEX
	Modbus address	3396, 3397	CANopen address	0x2B62, 0x00

PtP0.03	Position of segment 01	Setting range	Default	Unit	Applicable mode		
		$-(2^{31}-1)-(2^{31}-1)$	0	reference unit	P		
PtP0.05	Position of segment 02	Setting range	Default	Unit	Applicable mode		
		$-(2^{31}-1)-(2^{31}-1)$	0	reference unit	P		
PtP0.07	Position of segment 03	Setting range	Default	Unit	Applicable mode		
		$-(2^{31}-1)-(2^{31}-1)$	0	reference unit	P		
PtP0.09	Position of segment 04	Setting range	Default	Unit	Applicable mode		
		$-(2^{31}-1)-(2^{31}-1)$	0	reference unit	P		
PtP0.11	Position of segment 05	Setting range	Default	Unit	Applicable mode		
		$-(2^{31}-1)-(2^{31}-1)$	0	reference unit	P		
PtP0.13	Position of segment 06	Setting range	Default	Unit	Applicable mode		
		$-(2^{31}-1)-(2^{31}-1)$	0	reference unit	P		
PtP0.15	Position of segment 07	Setting range	Default	Unit	Applicable mode		
		$-(2^{31}-1)-(2^{31}-1)$	0	reference unit	P		
PtP0.17	Position of segment 08	Setting range	Default	Unit	Applicable mode		
		$-(2^{31}-1)-(2^{31}-1)$	0	reference unit	P		
PtP0.19	Position of segment 09	Setting range	Default	Unit	Applicable mode		
		$-(2^{31}-1)-(2^{31}-1)$	0	reference unit	P		
PtP0.21	Position of segment 10	Setting range	Default	Unit	Applicable mode		
		$-(2^{31}-1)-(2^{31}-1)$	0	reference unit	P		

PtP0.23	Position of segment 11	Setting range	Default	Unit	Applicable mode		
		$-(2^{31}-1)-(2^{31}-1)$	0	reference unit	P		
PtP0.25	Position of segment 12	Setting range	Default	Unit	Applicable mode		
		$-(2^{31}-1)-(2^{31}-1)$	0	reference unit	P		
PtP0.27	Position of segment 13	Setting range	Default	Unit	Applicable mode		
		$-(2^{31}-1)-(2^{31}-1)$	0	reference unit	P		
PtP0.29	Position of segment 14	Setting range	Default	Unit	Applicable mode		
		$-(2^{31}-1)-(2^{31}-1)$	0	reference unit	P		
PtP0.31	Position of segment 15	Setting range	Default	Unit	Applicable mode		
		$-(2^{31}-1)-(2^{31}-1)$	0	reference unit	P		
PtP0.33	Position of segment 16	Setting range	Default	Unit	Applicable mode		
		$-(2^{31}-1)-(2^{31}-1)$	0	reference unit	P		
PtP0.35	Position of segment 17	Setting range	Default	Unit	Applicable mode		
		$-(2^{31}-1)-(2^{31}-1)$	0	reference unit	P		
PtP0.37	Position of segment 18	Setting range	Default	Unit	Applicable mode		
		$-(2^{31}-1)-(2^{31}-1)$	0	reference unit	P		
PtP0.39	Position of segment 19	Setting range	Default	Unit	Applicable mode		
		$-(2^{31}-1)-(2^{31}-1)$	0	reference unit	P		
PtP0.41	Position of segment 20	Setting range	Default	Unit	Applicable mode		
		$-(2^{31}-1)-(2^{31}-1)$	0	reference unit	P		
PtP0.43	Position of segment 21	Setting range	Default	Unit	Applicable mode		
		$-(2^{31}-1)-(2^{31}-1)$	0	reference unit	P		
PtP0.45	Position of segment 22	Setting range	Default	Unit	Applicable mode		
		$-(2^{31}-1)-(2^{31}-1)$	0	reference unit	P		

PtP0.47	Position of segment 23	Setting range	Default	Unit	Applicable mode		
		$-(2^{31}-1)-(2^{31}-1)$	0	reference unit	P		
PtP0.49	Position of segment 24	Setting range	Default	Unit	Applicable mode		
		$-(2^{31}-1)-(2^{31}-1)$	0	reference unit	P		
PtP0.51	Position of segment 25	Setting range	Default	Unit	Applicable mode		
		$-(2^{31}-1)-(2^{31}-1)$	0	reference unit	P		
PtP0.53	Position of segment 26	Setting range	Default	Unit	Applicable mode		
		$-(2^{31}-1)-(2^{31}-1)$	0	reference unit	P		
PtP0.55	Position of segment 27	Setting range	Default	Unit	Applicable mode		
		$-(2^{31}-1)-(2^{31}-1)$	0	reference unit	P		
PtP0.57	Position of segment 28	Setting range	Default	Unit	Applicable mode		
		$-(2^{31}-1)-(2^{31}-1)$	0	reference unit	P		
PtP0.59	Position of segment 29	Setting range	Default	Unit	Applicable mode		
		$-(2^{31}-1)-(2^{31}-1)$	0	reference unit	P		
PtP0.61	Position of segment 30	Setting range	Default	Unit	Applicable mode		
		$-(2^{31}-1)-(2^{31}-1)$	0	reference unit	P		
PtP0.63	Position of segment 31	Setting range	Default	Unit	Applicable mode		
		$-(2^{31}-1)-(2^{31}-1)$	0	reference unit	P		
PtP0.65	Position of segment 32	Setting range	Default	Unit	Applicable mode		
		$-(2^{31}-1)-(2^{31}-1)$	0	reference unit	P		
PtP0.67	Position of segment 33	Setting range	Default	Unit	Applicable mode		
		$-(2^{31}-1)-(2^{31}-1)$	0	reference unit	P		
PtP0.69	Position of segment 34	Setting range	Default	Unit	Applicable mode		
		$-(2^{31}-1)-(2^{31}-1)$	0	reference unit	P		

PtP0.71	Position of segment 35	Setting range	Default	Unit	Applicable mode		
		$-(2^{31}-1)-(2^{31}-1)$	0	reference unit	P		
PtP0.73	Position of segment 36	Setting range	Default	Unit	Applicable mode		
		$-(2^{31}-1)-(2^{31}-1)$	0	reference unit	P		
PtP0.75	Position of segment 37	Setting range	Default	Unit	Applicable mode		
		$-(2^{31}-1)-(2^{31}-1)$	0	reference unit	P		
PtP0.77	Position of segment 38	Setting range	Default	Unit	Applicable mode		
		$-(2^{31}-1)-(2^{31}-1)$	0	reference unit	P		
PtP0.79	Position of segment 39	Setting range	Default	Unit	Applicable mode		
		$-(2^{31}-1)-(2^{31}-1)$	0	reference unit	P		
PtP0.81	Position of segment 40	Setting range	Default	Unit	Applicable mode		
		$-(2^{31}-1)-(2^{31}-1)$	0	reference unit	P		
PtP0.83	Position of segment 41	Setting range	Default	Unit	Applicable mode		
		$-(2^{31}-1)-(2^{31}-1)$	0	reference unit	P		
PtP0.85	Position of segment 42	Setting range	Default	Unit	Applicable mode		
		$-(2^{31}-1)-(2^{31}-1)$	0	reference unit	P		
PtP0.87	Position of segment 43	Setting range	Default	Unit	Applicable mode		
		$-(2^{31}-1)-(2^{31}-1)$	0	reference unit	P		
PtP0.89	Position of segment 44	Setting range	Default	Unit	Applicable mode		
		$-(2^{31}-1)-(2^{31}-1)$	0	reference unit	P		
PtP0.91	Position of segment 45	Setting range	Default	Unit	Applicable mode		
		$-(2^{31}-1)-(2^{31}-1)$	0	reference unit	P		
PtP0.93	Position of segment 46	Setting range	Default	Unit	Applicable mode		
		$-(2^{31}-1)-(2^{31}-1)$	0	reference unit	P		

PtP0.95	Position of segment 47	Setting range	Default	Unit	Applicable mode		
		$-(2^{31}-1)-(2^{31}-1)$	0	reference unit	P		
PtP0.97	Position of segment 48	Setting range	Default	Unit	Applicable mode		
		$-(2^{31}-1)-(2^{31}-1)$	0	reference unit	P		
PtP0.99	Position of segment 49	Setting range	Default	Unit	Applicable mode		
		$-(2^{31}-1)-(2^{31}-1)$	0	reference unit	P		

This group of parameter specifies the positions of segments 01 to 49. The CMD attribute determines the position command mode of a segment. P0.37 is inapplicable to this group.

PtP0.03	Data size	32bit	Data format	DEC
	Modbus address	3206, 3207	CANopen address	0x2B03, 0x00
PtP0.05	Data size	32bit	Data format	DEC
	Modbus address	3210, 3211	CANopen address	0x2B05, 0x00
PtP0.07	Data size	32bit	Data format	DEC
	Modbus address	3214, 3015	CANopen address	0x2B07, 0x00
PtP0.09	Data size	32bit	Data format	DEC
	Modbus address	3218, 3219	CANopen address	0x2B09, 0x00
PtP0.11	Data size	32bit	Data format	DEC
	Modbus address	3222, 3223	CANopen address	0x2B0B, 0x00
PtP0.13	Data size	32bit	Data format	DEC
	Modbus address	3226, 3227	CANopen address	0x2B0D, 0x00
PtP0.15	Data size	32bit	Data format	DEC
	Modbus address	3230, 3231	CANopen address	0x2B0F, 0x00
PtP0.17	Data size	32bit	Data format	DEC
	Modbus address	3234, 3235	CANopen address	0x2B11, 0x00
PtP0.19	Data size	32bit	Data format	DEC
	Modbus address	3238, 3239	CANopen address	0x2B13, 0x00
PtP0.21	Data size	32bit	Data format	DEC
	Modbus address	3242, 3243	CANopen address	0x2B15, 0x00
PtP0.23	Data size	32bit	Data format	DEC
	Modbus address	3246, 3247	CANopen address	0x2B17, 0x00
PtP0.25	Data size	32bit	Data format	DEC
	Modbus address	3250, 3251	CANopen address	0x2B19, 0x00
PtP0.27	Data size	32bit	Data format	DEC
	Modbus address	3254, 3255	CANopen address	0x2B1B, 0x00

PtP0.29	Data size	32bit	Data format	DEC
	Modbus address	3258, 3259	CANopen address	0x2B1D, 0x00
PtP0.31	Data size	32bit	Data format	DEC
	Modbus address	3262, 3263	CANopen address	0x2B1F, 0x00
PtP0.33	Data size	32bit	Data format	DEC
	Modbus address	3266, 3267	CANopen address	0x2B21, 0x00
PtP0.35	Data size	32bit	Data format	DEC
	Modbus address	3270, 3271	CANopen address	0x2B23, 0x00
PtP0.37	Data size	32bit	Data format	DEC
	Modbus address	3274, 3075	CANopen address	0x2B25, 0x00
PtP0.39	Data size	32bit	Data format	DEC
	Modbus address	3278, 3279	CANopen address	0x2B27, 0x00
PtP0.41	Data size	32bit	Data format	DEC
	Modbus address	3282, 3283	CANopen address	0x2B29, 0x00
PtP0.43	Data size	32bit	Data format	DEC
	Modbus address	3286, 3287	CANopen address	0x2B2B, 0x00
PtP0.45	Data size	32bit	Data format	DEC
	Modbus address	3290, 3291	CANopen address	0x2B2D, 0x00
PtP0.47	Data size	32bit	Data format	DEC
	Modbus address	3294, 3295	CANopen address	0x2B2F, 0x00
PtP0.49	Data size	32bit	Data format	DEC
	Modbus address	3298, 3299	CANopen address	0x2B31, 0x00
PtP0.51	Data size	32bit	Data format	DEC
	Modbus address	3302, 3303	CANopen address	0x2B33, 0x00
PtP0.53	Data size	32bit	Data format	DEC
	Modbus address	3306, 3307	CANopen address	0x2B35, 0x00
PtP0.55	Data size	32bit	Data format	DEC
	Modbus address	3310, 3311	CANopen address	0x2B37, 0x00
PtP0.57	Data size	32bit	Data format	DEC
	Modbus address	3314, 3315	CANopen address	0x2B39, 0x00
PtP0.59	Data size	32bit	Data format	DEC
	Modbus address	3318, 3319	CANopen address	0x2B3B, 0x00
PtP0.61	Data size	32bit	Data format	DEC
	Modbus address	3322, 3323	CANopen address	0x2B3D, 0x00
PtP0.63	Data size	32bit	Data format	DEC
	Modbus address	3326, 3327	CANopen address	0x2B3F, 0x00
PtP0.65	Data size	32bit	Data format	DEC

	Modbus address	3330, 3331	CANopen address	0x2B41, 0x00
PtP0.67	Data size	32bit	Data format	DEC
	Modbus address	3334, 3335	CANopen address	0x2B43, 0x00
PtP0.69	Data size	32bit	Data format	DEC
	Modbus address	3338, 3339	CANopen address	0x2B45, 0x00
PtP0.71	Data size	32bit	Data format	DEC
	Modbus address	3342, 3343	CANopen address	0x2B47, 0x00
PtP0.73	Data size	32bit	Data format	DEC
	Modbus address	3346, 3347	CANopen address	0x2B49, 0x00
PtP0.75	Data size	32bit	Data format	DEC
	Modbus address	3350, 3351	CANopen address	0x2B4B, 0x00
PtP0.77	Data size	32bit	Data format	DEC
	Modbus address	3354, 3355	CANopen address	0x2B4D, 0x00
PtP0.79	Data size	32bit	Data format	DEC
	Modbus address	3358, 3359	CANopen address	0x2B4F, 0x00
PtP0.81	Data size	32bit	Data format	DEC
	Modbus address	3362, 3363	CANopen address	0x2B51, 0x00
PtP0.83	Data size	32bit	Data format	DEC
	Modbus address	3366, 3367	CANopen address	0x2B53, 0x00
PtP0.85	Data size	32bit	Data format	DEC
	Modbus address	3370, 3371	CANopen address	0x2B55, 0x00
PtP0.87	Data size	32bit	Data format	DEC
	Modbus address	3374, 3375	CANopen address	0x2B57, 0x00
PtP0.89	Data size	32bit	Data format	DEC
	Modbus address	3378, 3379	CANopen address	0x2B59, 0x00
PtP0.91	Data size	32bit	Data format	DEC
	Modbus address	3382, 3383	CANopen address	0x2B5B, 0x00
PtP0.93	Data size	32bit	Data format	DEC
	Modbus address	3386, 3387	CANopen address	0x2B5D, 0x00
PtP0.95	Data size	32bit	Data format	DEC
	Modbus address	3390, 3391	CANopen address	0x2B5F, 0x00
PtP0.97	Data size	32bit	Data format	DEC
	Modbus address	3394, 3395	CANopen address	0x2B61, 0x00
PtP0.99	Data size	32bit	Data format	DEC
	Modbus address	3398, 3399	CANopen address	0x2B63, 0x00

PtP1.00	Control word of segment 50	Setting range	Default	Unit	Applicable mode		
		0-0x7FFFFFFF	0x00000000	-	P		
PtP1.02	Control word of segment 51	Setting range	Default	Unit	Applicable mode		
		0-0x7FFFFFFF	0x00000000	-	P		
PtP1.04	Control word of segment 52	Setting range	Default	Unit	Applicable mode		
		0-0x7FFFFFFF	0x00000000	-	P		
PtP1.06	Control word of segment 53	Setting range	Default	Unit	Applicable mode		
		0-0x7FFFFFFF	0x00000000	-	P		
PtP1.08	Control word of segment 54	Setting range	Default	Unit	Applicable mode		
		0-0x7FFFFFFF	0x00000000	-	P		
PtP1.10	Control word of segment 55	Setting range	Default	Unit	Applicable mode		
		0-0x7FFFFFFF	0x00000000	-	P		
PtP1.12	Control word of segment 56	Setting range	Default	Unit	Applicable mode		
		0-0x7FFFFFFF	0x00000000	-	P		
PtP1.14	Control word of segment 57	Setting range	Default	Unit	Applicable mode		
		0-0x7FFFFFFF	0x00000000	-	P		
PtP1.16	Control word of segment 58	Setting range	Default	Unit	Applicable mode		
		0-0x7FFFFFFF	0x00000000	-	P		
PtP1.18	Control word of segment 59	Setting range	Default	Unit	Applicable mode		
		0-0x7FFFFFFF	0x00000000	-	P		
PtP1.20	Control word of segment 60	Setting range	Default	Unit	Applicable mode		
		0-0x7FFFFFFF	0x00000000	-	P		
PtP1.22	Control word of segment 61	Setting range	Default	Unit	Applicable mode		
		0-0x7FFFFFFF	0x00000000	-	P		

PtP1.24	Control word of segment 62	Setting range	Default	Unit	Applicable mode		
		0-0x7FFFFFFF	0x00000000	-	P		
PtP1.26	Control word of segment 63	Setting range	Default	Unit	Applicable mode		
		0-0x7FFFFFFF	0x00000000	-	P		
PtP1.28	Control word of segment 64	Setting range	Default	Unit	Applicable mode		
		0-0x7FFFFFFF	0x00000000	-	P		
PtP1.30	Control word of segment 65	Setting range	Default	Unit	Applicable mode		
		0-0x7FFFFFFF	0x00000000	-	P		
PtP1.32	Control word of segment 66	Setting range	Default	Unit	Applicable mode		
		0-0x7FFFFFFF	0x00000000	-	P		
PtP1.34	Control word of segment 67	Setting range	Default	Unit	Applicable mode		
		0-0x7FFFFFFF	0x00000000	-	P		
PtP1.36	Control word of segment 68	Setting range	Default	Unit	Applicable mode		
		0-0x7FFFFFFF	0x00000000	-	P		
PtP1.38	Control word of segment 69	Setting range	Default	Unit	Applicable mode		
		0-0x7FFFFFFF	0x00000000	-	P		
PtP1.40	Control word of segment 70	Setting range	Default	Unit	Applicable mode		
		0-0x7FFFFFFF	0x00000000	-	P		
PtP1.42	Control word of segment 71	Setting range	Default	Unit	Applicable mode		
		0-0x7FFFFFFF	0x00000000	-	P		
PtP1.44	Control word of segment 72	Setting range	Default	Unit	Applicable mode		
		0-0x7FFFFFFF	0x00000000	-	P		
PtP1.46	Control word of segment 73	Setting range	Default	Unit	Applicable mode		
		0-0x7FFFFFFF	0x00000000	-	P		

PtP1.48	Control word of segment 74	Setting range	Default	Unit	Applicable mode		
		0-0x7FFFFFFF	0x00000000	-	P		
PtP1.50	Control word of segment 75	Setting range	Default	Unit	Applicable mode		
		0-0x7FFFFFFF	0x00000000	-	P		
PtP1.52	Control word of segment 76	Setting range	Default	Unit	Applicable mode		
		0-0x7FFFFFFF	0x00000000	-	P		
PtP1.54	Control word of segment 77	Setting range	Default	Unit	Applicable mode		
		0-0x7FFFFFFF	0x00000000	-	P		
PtP1.56	Control word of segment 78	Setting range	Default	Unit	Applicable mode		
		0-0x7FFFFFFF	0x00000000	-	P		
PtP1.58	Control word of segment 79	Setting range	Default	Unit	Applicable mode		
		0-0x7FFFFFFF	0x00000000	-	P		
PtP1.60	Control word of segment 80	Setting range	Default	Unit	Applicable mode		
		0-0x7FFFFFFF	0x00000000	-	P		
PtP1.62	Control word of segment 81	Setting range	Default	Unit	Applicable mode		
		0-0x7FFFFFFF	0x00000000	-	P		
PtP1.64	Control word of segment 82	Setting range	Default	Unit	Applicable mode		
		0-0x7FFFFFFF	0x00000000	-	P		
PtP1.66	Control word of segment 83	Setting range	Default	Unit	Applicable mode		
		0-0x7FFFFFFF	0x00000000	-	P		
PtP1.68	Control word of segment 84	Setting range	Default	Unit	Applicable mode		
		0-0x7FFFFFFF	0x00000000	-	P		
PtP1.70	Control word of segment 85	Setting range	Default	Unit	Applicable mode		
		0-0x7FFFFFFF	0x00000000	-	P		

PtP1.72	Control word of segment 86	Setting range	Default	Unit	Applicable mode		
		0-0x7FFFFFFF	0x00000000	-	P		
PtP1.74	Control word of segment 87	Setting range	Default	Unit	Applicable mode		
		0-0x7FFFFFFF	0x00000000	-	P		
PtP1.76	Control word of segment 88	Setting range	Default	Unit	Applicable mode		
		0-0x7FFFFFFF	0x00000000	-	P		
PtP1.78	Control word of segment 89	Setting range	Default	Unit	Applicable mode		
		0-0x7FFFFFFF	0x00000000	-	P		
PtP1.80	Control word of segment 90	Setting range	Default	Unit	Applicable mode		
		0-0x7FFFFFFF	0x00000000	-	P		
PtP1.82	Control word of segment 91	Setting range	Default	Unit	Applicable mode		
		0-0x7FFFFFFF	0x00000000	-	P		
PtP1.84	Control word of segment 92	Setting range	Default	Unit	Applicable mode		
		0-0x7FFFFFFF	0x00000000	-	P		
PtP1.86	Control word of segment 93	Setting range	Default	Unit	Applicable mode		
		0-0x7FFFFFFF	0x00000000	-	P		
PtP1.88	Control word of segment 94	Setting range	Default	Unit	Applicable mode		
		0-0x7FFFFFFF	0x00000000	-	P		
PtP1.90	Control word of segment 95	Setting range	Default	Unit	Applicable mode		
		0-0x7FFFFFFF	0x00000000	-	P		
PtP1.92	Control word of segment 96	Setting range	Default	Unit	Applicable mode		
		0-0x7FFFFFFF	0x00000000	-	P		
PtP1.94	Control word of segment 97	Setting range	Default	Unit	Applicable mode		
		0-0x7FFFFFFF	0x00000000	-	P		

PtP1.96	Control word of segment 98	Setting range	Default	Unit	Applicable mode		
		0-0x7FFFFFFF	0x00000000	-	P		
PtP1.98	Control word of segment 99	Setting range	Default	Unit	Applicable mode		
		0-0x7FFFFFFF	0x00000000	-	P		
This group of parameter specifies the control words of segments 50 to 99. For details, see the description for PtP0.00.							
PtP1.00	Data size	32bit	Data format	HEX			
	Modbus address	3400, 3401	CANopen address	0x2C00, 0x00			
PtP1.02	Data size	32bit	Data format	HEX			
	Modbus address	3404, 3405	CANopen address	0x2C02, 0x00			
PtP1.04	Data size	32bit	Data format	HEX			
	Modbus address	3408, 3409	CANopen address	0x2C04, 0x00			
PtP1.06	Data size	32bit	Data format	HEX			
	Modbus address	3412, 3413	CANopen address	0x2C06, 0x00			
PtP1.08	Data size	32bit	Data format	HEX			
	Modbus address	3416, 3417	CANopen address	0x2C08, 0x00			
PtP1.10	Data size	32bit	Data format	HEX			
	Modbus address	3420, 3421	CANopen address	0x2C0A, 0x00			
PtP1.12	Data size	32bit	Data format	HEX			
	Modbus address	3424, 3425	CANopen address	0x2C0C, 0x00			
PtP1.14	Data size	32bit	Data format	HEX			
	Modbus address	3428, 3429	CANopen address	0x2C0E, 0x00			
PtP1.16	Data size	32bit	Data format	HEX			
	Modbus address	3432, 3433	CANopen address	0x2C10, 0x00			
PtP1.18	Data size	32bit	Data format	HEX			
	Modbus address	3436, 3437	CANopen address	0x2C12, 0x00			
PtP1.20	Data size	32bit	Data format	HEX			
	Modbus address	3440, 3441	CANopen address	0x2C14, 0x00			
PtP1.22	Data size	32bit	Data format	HEX			
	Modbus address	3444, 3445	CANopen address	0x2C16, 0x00			
PtP1.24	Data size	32bit	Data format	HEX			
	Modbus address	3448, 3449	CANopen address	0x2C18, 0x00			
PtP1.26	Data size	32bit	Data format	HEX			
	Modbus address	3452, 3453	CANopen address	0x2C1A, 0x00			
PtP1.28	Data size	32bit	Data format	HEX			

	Modbus address	3456, 3457	CANopen address	0x2C1C, 0x00
PtP1.30	Data size	32bit	Data format	HEX
	Modbus address	3460, 3461	CANopen address	0x2C1E, 0x00
PtP1.32	Data size	32bit	Data format	HEX
	Modbus address	3464, 3465	CANopen address	0x2C20, 0x00
PtP1.34	Data size	32bit	Data format	HEX
	Modbus address	3468, 3469	CANopen address	0x2C22, 0x00
PtP1.36	Data size	32bit	Data format	HEX
	Modbus address	3472, 3473	CANopen address	0x2C24, 0x00
PtP1.38	Data size	32bit	Data format	HEX
	Modbus address	3476, 3477	CANopen address	0x2C26, 0x00
PtP1.40	Data size	32bit	Data format	HEX
	Modbus address	3480, 3481	CANopen address	0x2C28, 0x00
PtP1.42	Data size	32bit	Data format	HEX
	Modbus address	3484, 3485	CANopen address	0x2C2A, 0x00
PtP1.44	Data size	32bit	Data format	HEX
	Modbus address	3488, 3489	CANopen address	0x2C2C, 0x00
PtP1.46	Data size	32bit	Data format	HEX
	Modbus address	3492, 3493	CANopen address	0x2C2E, 0x00
PtP1.48	Data size	32bit	Data format	HEX
	Modbus address	3496, 3497	CANopen address	0x2C30, 0x00
PtP1.50	Data size	32bit	Data format	HEX
	Modbus address	3500, 3501	CANopen address	0x2C32, 0x00
PtP1.52	Data size	32bit	Data format	HEX
	Modbus address	3504, 3505	CANopen address	0x2C34, 0x00
PtP1.54	Data size	32bit	Data format	HEX
	Modbus address	3508, 3509	CANopen address	0x2C36, 0x00
PtP1.56	Data size	32bit	Data format	HEX
	Modbus address	3512, 3513	CANopen address	0x2C38, 0x00
PtP1.58	Data size	32bit	Data format	HEX
	Modbus address	3516, 3517	CANopen address	0x2C3A, 0x00
PtP1.60	Data size	32bit	Data format	HEX
	Modbus address	3520, 3521	CANopen address	0x2C3C, 0x00
PtP1.62	Data size	32bit	Data format	HEX
	Modbus address	3524, 3525	CANopen address	0x2C3E, 0x00
PtP1.64	Data size	32bit	Data format	HEX
	Modbus address	3528, 3529	CANopen address	0x2C40, 0x00

PtP1.66	Data size	32bit	Data format	HEX
	Modbus address	3532, 3533	CANopen address	0x2C42, 0x00
PtP1.68	Data size	32bit	Data format	HEX
	Modbus address	3536, 3537	CANopen address	0x2C44, 0x00
PtP1.70	Data size	32bit	Data format	HEX
	Modbus address	3540, 3541	CANopen address	0x2C46, 0x00
PtP1.72	Data size	32bit	Data format	HEX
	Modbus address	3544, 3545	CANopen address	0x2C48, 0x00
PtP1.74	Data size	32bit	Data format	HEX
	Modbus address	3548, 3549	CANopen address	0x2C4A, 0x00
PtP1.76	Data size	32bit	Data format	HEX
	Modbus address	3552, 3553	CANopen address	0x2C4C, 0x00
PtP1.78	Data size	32bit	Data format	HEX
	Modbus address	3556, 3557	CANopen address	0x2C4E, 0x00
PtP1.80	Data size	32bit	Data format	HEX
	Modbus address	3560, 3561	CANopen address	0x2C50, 0x00
PtP1.82	Data size	32bit	Data format	HEX
	Modbus address	3564, 3565	CANopen address	0x2C52, 0x00
PtP1.84	Data size	32bit	Data format	HEX
	Modbus address	3568, 3569	CANopen address	0x2C54, 0x00
PtP1.86	Data size	32bit	Data format	HEX
	Modbus address	3572, 3573	CANopen address	0x2C56, 0x00
PtP1.88	Data size	32bit	Data format	HEX
	Modbus address	3576, 3577	CANopen address	0x2C58, 0x00
PtP1.90	Data size	32bit	Data format	HEX
	Modbus address	3580, 3581	CANopen address	0x2C5A, 0x00
PtP1.92	Data size	32bit	Data format	HEX
	Modbus address	3584, 3585	CANopen address	0x2C5C, 0x00
PtP1.94	Data size	32bit	Data format	HEX
	Modbus address	3588, 3589	CANopen address	0x2C5E, 0x00
PtP1.96	Data size	32bit	Data format	HEX
	Modbus address	3592, 3593	CANopen address	0x2C60, 0x00
PtP1.98	Data size	32bit	Data format	HEX
	Modbus address	3596, 3597	CANopen address	0x2C62, 0x00

PtP1.01	Position of segment 50	Setting range	Default	Unit	Applicable mode		
		$-(2^{31}-1)-(2^{31}-1)$	0	reference unit	P		
PtP1.03	Position of segment 51	Setting range	Default	Unit	Applicable mode		
		$-(2^{31}-1)-(2^{31}-1)$	0	reference unit	P		
PtP1.05	Position of segment 52	Setting range	Default	Unit	Applicable mode		
		$-(2^{31}-1)-(2^{31}-1)$	0	reference unit	P		
PtP1.07	Position of segment 53	Setting range	Default	Unit	Applicable mode		
		$-(2^{31}-1)-(2^{31}-1)$	0	reference unit	P		
PtP1.09	Position of segment 54	Setting range	Default	Unit	Applicable mode		
		$-(2^{31}-1)-(2^{31}-1)$	0	reference unit	P		
PtP1.11	Position of segment 55	Setting range	Default	Unit	Applicable mode		
		$-(2^{31}-1)-(2^{31}-1)$	0	reference unit	P		
PtP1.13	Position of segment 56	Setting range	Default	Unit	Applicable mode		
		$-(2^{31}-1)-(2^{31}-1)$	0	reference unit	P		
PtP1.15	Position of segment 57	Setting range	Default	Unit	Applicable mode		
		$-(2^{31}-1)-(2^{31}-1)$	0	reference unit	P		
PtP1.17	Position of segment 58	Setting range	Default	Unit	Applicable mode		
		$-(2^{31}-1)-(2^{31}-1)$	0	reference unit	P		
PtP1.19	Position of segment 59	Setting range	Default	Unit	Applicable mode		
		$-(2^{31}-1)-(2^{31}-1)$	0	reference unit	P		
PtP1.21	Position of segment 60	Setting range	Default	Unit	Applicable mode		
		$-(2^{31}-1)-(2^{31}-1)$	0	reference unit	P		
PtP1.23	Position of segment 61	Setting range	Default	Unit	Applicable mode		
		$-(2^{31}-1)-(2^{31}-1)$	0	reference unit	P		

PtP1.25	Position of segment 62	Setting range	Default	Unit	Applicable mode		
		$-(2^{31}-1)-(2^{31}-1)$	0	reference unit	P		
PtP1.27	Position of segment 63	Setting range	Default	Unit	Applicable mode		
		$-(2^{31}-1)-(2^{31}-1)$	0	reference unit	P		
PtP1.29	Position of segment 64	Setting range	Default	Unit	Applicable mode		
		$-(2^{31}-1)-(2^{31}-1)$	0	reference unit	P		
PtP1.31	Position of segment 65	Setting range	Default	Unit	Applicable mode		
		$-(2^{31}-1)-(2^{31}-1)$	0	reference unit	P		
PtP1.33	Position of segment 66	Setting range	Default	Unit	Applicable mode		
		$-(2^{31}-1)-(2^{31}-1)$	0	reference unit	P		
PtP1.35	Position of segment 67	Setting range	Default	Unit	Applicable mode		
		$-(2^{31}-1)-(2^{31}-1)$	0	reference unit	P		
PtP1.37	Position of segment 68	Setting range	Default	Unit	Applicable mode		
		$-(2^{31}-1)-(2^{31}-1)$	0	reference unit	P		
PtP1.39	Position of segment 69	Setting range	Default	Unit	Applicable mode		
		$-(2^{31}-1)-(2^{31}-1)$	0	reference unit	P		
PtP1.41	Position of segment 70	Setting range	Default	Unit	Applicable mode		
		$-(2^{31}-1)-(2^{31}-1)$	0	reference unit	P		
PtP1.43	Position of segment 71	Setting range	Default	Unit	Applicable mode		
		$-(2^{31}-1)-(2^{31}-1)$	0	reference unit	P		
PtP1.45	Position of segment 72	Setting range	Default	Unit	Applicable mode		
		$-(2^{31}-1)-(2^{31}-1)$	0	reference unit	P		
PtP1.47	Position of segment 73	Setting range	Default	Unit	Applicable mode		
		$-(2^{31}-1)-(2^{31}-1)$	0	reference unit	P		

PtP1.49	Position of segment 74	Setting range	Default	Unit	Applicable mode		
		$-(2^{31}-1)-(2^{31}-1)$	0	reference unit	P		
PtP1.51	Position of segment 75	Setting range	Default	Unit	Applicable mode		
		$-(2^{31}-1)-(2^{31}-1)$	0	reference unit	P		
PtP1.53	Position of segment 76	Setting range	Default	Unit	Applicable mode		
		$-(2^{31}-1)-(2^{31}-1)$	0	reference unit	P		
PtP1.55	Position of segment 77	Setting range	Default	Unit	Applicable mode		
		$-(2^{31}-1)-(2^{31}-1)$	0	reference unit	P		
PtP1.57	Position of segment 78	Setting range	Default	Unit	Applicable mode		
		$-(2^{31}-1)-(2^{31}-1)$	0	reference unit	P		
PtP1.59	Position of segment 79	Setting range	Default	Unit	Applicable mode		
		$-(2^{31}-1)-(2^{31}-1)$	0	reference unit	P		
PtP1.61	Position of segment 80	Setting range	Default	Unit	Applicable mode		
		$-(2^{31}-1)-(2^{31}-1)$	0	reference unit	P		
PtP1.63	Position of segment 81	Setting range	Default	Unit	Applicable mode		
		$-(2^{31}-1)-(2^{31}-1)$	0	reference unit	P		
PtP1.65	Position of segment 82	Setting range	Default	Unit	Applicable mode		
		$-(2^{31}-1)-(2^{31}-1)$	0	reference unit	P		
PtP1.67	Position of segment 83	Setting range	Default	Unit	Applicable mode		
		$-(2^{31}-1)-(2^{31}-1)$	0	reference unit	P		
PtP1.69	Position of segment 84	Setting range	Default	Unit	Applicable mode		
		$-(2^{31}-1)-(2^{31}-1)$	0	reference unit	P		
PtP1.71	Position of segment 85	Setting range	Default	Unit	Applicable mode		
		$-(2^{31}-1)-(2^{31}-1)$	0	reference unit	P		

PtP1.73	Position of segment 86	Setting range	Default	Unit	Applicable mode		
		$-(2^{31}-1)-(2^{31}-1)$	0	reference unit	P		
PtP1.75	Position of segment 87	Setting range	Default	Unit	Applicable mode		
		$-(2^{31}-1)-(2^{31}-1)$	0	reference unit	P		
PtP1.77	Position of segment 88	Setting range	Default	Unit	Applicable mode		
		$-(2^{31}-1)-(2^{31}-1)$	0	reference unit	P		
PtP1.79	Position of segment 89	Setting range	Default	Unit	Applicable mode		
		$-(2^{31}-1)-(2^{31}-1)$	0	reference unit	P		
PtP1.81	Position of segment 90	Setting range	Default	Unit	Applicable mode		
		$-(2^{31}-1)-(2^{31}-1)$	0	reference unit	P		
PtP1.83	Position of segment 91	Setting range	Default	Unit	Applicable mode		
		$-(2^{31}-1)-(2^{31}-1)$	0	reference unit	P		
PtP1.85	Position of segment 92	Setting range	Default	Unit	Applicable mode		
		$-(2^{31}-1)-(2^{31}-1)$	0	reference unit	P		
PtP1.87	Position of segment 93	Setting range	Default	Unit	Applicable mode		
		$-(2^{31}-1)-(2^{31}-1)$	0	reference unit	P		
PtP1.89	Position of segment 94	Setting range	Default	Unit	Applicable mode		
		$-(2^{31}-1)-(2^{31}-1)$	0	reference unit	P		
PtP1.91	Position of segment 95	Setting range	Default	Unit	Applicable mode		
		$-(2^{31}-1)-(2^{31}-1)$	0	reference unit	P		
PtP1.93	Position of segment 96	Setting range	Default	Unit	Applicable mode		
		$-(2^{31}-1)-(2^{31}-1)$	0	reference unit	P		
PtP1.95	Position of segment 97	Setting range	Default	Unit	Applicable mode		
		$-(2^{31}-1)-(2^{31}-1)$	0	reference unit	P		

PtP1.97	Position of segment 98	Setting range	Default	Unit	Applicable mode		
		$-(2^{31}-1)-(2^{31}-1)$	0	reference unit	P		
PtP1.99	Position of segment 99	Setting range	Default	Unit	Applicable mode		
		$-(2^{31}-1)-(2^{31}-1)$	0	reference unit	P		
This group of parameter specifies the positions of segments 50 to 99. The CMD attribute determines the position command mode of a segment. P0.37 is inapplicable to this group.							
PtP1.01	Data size	32bit	Data format	DEC			
	Modbus address	3402, 3403	CANopen address	0x2C03, 0x00			
PtP1.03	Data size	32bit	Data format	DEC			
	Modbus address	3406, 3407	CANopen address	0x2C03, 0x00			
PtP1.05	Data size	32bit	Data format	DEC			
	Modbus address	3410, 3411	CANopen address	0x2C05, 0x00			
PtP1.07	Data size	32bit	Data format	DEC			
	Modbus address	3414, 3415	CANopen address	0x2C07, 0x00			
PtP1.09	Data size	32bit	Data format	DEC			
	Modbus address	3418, 3419	CANopen address	0x2C09, 0x00			
PtP1.11	Data size	32bit	Data format	DEC			
	Modbus address	3422, 3423	CANopen address	0x2C0B, 0x00			
PtP1.13	Data size	32bit	Data format	DEC			
	Modbus address	3426, 3427	CANopen address	0x2C0D, 0x00			
PtP1.15	Data size	32bit	Data format	DEC			
	Modbus address	3430, 3431	CANopen address	0x2C0F, 0x00			
PtP1.17	Data size	32bit	Data format	DEC			
	Modbus address	3434, 3435	CANopen address	0x2C11, 0x00			
PtP1.19	Data size	32bit	Data format	DEC			
	Modbus address	3438, 3439	CANopen address	0x2C13, 0x00			
PtP1.21	Data size	32bit	Data format	DEC			
	Modbus address	3442, 3443	CANopen address	0x2C15, 0x00			
PtP1.23	Data size	32bit	Data format	DEC			
	Modbus address	3446, 3447	CANopen address	0x2C17, 0x00			
PtP1.25	Data size	32bit	Data format	DEC			
	Modbus address	3450, 3451	CANopen address	0x2C19, 0x00			
PtP1.27	Data size	32bit	Data format	DEC			
	Modbus address	3454, 3455	CANopen address	0x2C1B, 0x00			
PtP1.29	Data size	32bit	Data format	DEC			

	Modbus address	3458, 3459	CANopen address	0x2C1D, 0x00
PtP1.31	Data size	32bit	Data format	DEC
	Modbus address	3462, 3463	CANopen address	0x2C1F, 0x00
PtP1.33	Data size	32bit	Data format	DEC
	Modbus address	3466, 3467	CANopen address	0x2C21, 0x00
PtP1.35	Data size	32bit	Data format	DEC
	Modbus address	3470, 3471	CANopen address	0x2C23, 0x00
PtP1.37	Data size	32bit	Data format	DEC
	Modbus address	3474, 3475	CANopen address	0x2C25, 0x00
PtP1.39	Data size	32bit	Data format	DEC
	Modbus address	3478, 3479	CANopen address	0x2C27, 0x00
PtP1.41	Data size	32bit	Data format	DEC
	Modbus address	3482, 3483	CANopen address	0x2C29, 0x00
PtP1.43	Data size	32bit	Data format	DEC
	Modbus address	3486, 3487	CANopen address	0x2C2B, 0x00
PtP1.45	Data size	32bit	Data format	DEC
	Modbus address	3490, 3491	CANopen address	0x2C2D, 0x00
PtP1.47	Data size	32bit	Data format	DEC
	Modbus address	3494, 3495	CANopen address	0x2C2F, 0x00
PtP1.49	Data size	32bit	Data format	DEC
	Modbus address	3498, 3499	CANopen address	0x2C31, 0x00
PtP1.51	Data size	32bit	Data format	DEC
	Modbus address	3502, 3503	CANopen address	0x2C33, 0x00
PtP1.53	Data size	32bit	Data format	DEC
	Modbus address	3506, 3507	CANopen address	0x2C35, 0x00
PtP1.55	Data size	32bit	Data format	DEC
	Modbus address	3510, 3511	CANopen address	0x2C37, 0x00
PtP1.57	Data size	32bit	Data format	DEC
	Modbus address	3514, 3515	CANopen address	0x2C39, 0x00
PtP1.59	Data size	32bit	Data format	DEC
	Modbus address	3518, 3519	CANopen address	0x2C3B, 0x00
PtP1.61	Data size	32bit	Data format	DEC
	Modbus address	3522, 3523	CANopen address	0x2C3D, 0x00
PtP1.63	Data size	32bit	Data format	DEC
	Modbus address	3526, 3527	CANopen address	0x2C3F, 0x00
PtP1.65	Data size	32bit	Data format	DEC
	Modbus address	3530, 3531	CANopen address	0x2C41, 0x00

PtP1.67	Data size	32bit	Data format	DEC
	Modbus address	3534, 3535	CANopen address	0x2C43, 0x00
PtP1.69	Data size	32bit	Data format	DEC
	Modbus address	3538, 3539	CANopen address	0x2C45, 0x00
PtP1.71	Data size	32bit	Data format	DEC
	Modbus address	3542, 3543	CANopen address	0x2C47, 0x00
PtP1.73	Data size	32bit	Data format	DEC
	Modbus address	3546, 3547	CANopen address	0x2C49, 0x00
PtP1.75	Data size	32bit	Data format	DEC
	Modbus address	3550, 3551	CANopen address	0x2C4B, 0x00
PtP1.77	Data size	32bit	Data format	DEC
	Modbus address	3554, 3555	CANopen address	0x2C4D, 0x00
PtP1.79	Data size	32bit	Data format	DEC
	Modbus address	3558, 3559	CANopen address	0x2C4F, 0x00
PtP1.81	Data size	32bit	Data format	DEC
	Modbus address	3562, 3563	CANopen address	0x2C51, 0x00
PtP1.83	Data size	32bit	Data format	DEC
	Modbus address	3566, 3567	CANopen address	0x2C53, 0x00
PtP1.85	Data size	32bit	Data format	DEC
	Modbus address	3570, 3571	CANopen address	0x2C55, 0x00
PtP1.87	Data size	32bit	Data format	DEC
	Modbus address	3574, 3575	CANopen address	0x2C57, 0x00
PtP1.89	Data size	32bit	Data format	DEC
	Modbus address	3578, 3579	CANopen address	0x2C59, 0x00
PtP1.91	Data size	32bit	Data format	DEC
	Modbus address	3582, 3583	CANopen address	0x2C5B, 0x00
PtP1.93	Data size	32bit	Data format	DEC
	Modbus address	3586, 3587	CANopen address	0x2C5D, 0x00
PtP1.95	Data size	32bit	Data format	DEC
	Modbus address	3590, 3591	CANopen address	0x2C5F, 0x00
PtP1.97	Data size	32bit	Data format	DEC
	Modbus address	3594, 3595	CANopen address	0x2C61, 0x00
PtP1.99	Data size	32bit	Data format	DEC
	Modbus address	3598, 3599	CANopen address	0x2C63, 0x00

PtP2.00	Control word of segment 100	Setting range	Default	Unit	Applicable mode		
		0-0x7FFFFFFF	0x00000000	-	P		
PtP2.02	Control word of segment 101	Setting range	Default	Unit	Applicable mode		
		0-0x7FFFFFFF	0x00000000	-	P		
PtP2.04	Control word of segment 102	Setting range	Default	Unit	Applicable mode		
		0-0x7FFFFFFF	0x00000000	-	P		
PtP2.06	Control word of segment 103	Setting range	Default	Unit	Applicable mode		
		0-0x7FFFFFFF	0x00000000	-	P		
PtP2.08	Control word of segment 104	Setting range	Default	Unit	Applicable mode		
		0-0x7FFFFFFF	0x00000000	-	P		
PtP2.10	Control word of segment 105	Setting range	Default	Unit	Applicable mode		
		0-0x7FFFFFFF	0x00000000	-	P		
PtP2.12	Control word of segment 106	Setting range	Default	Unit	Applicable mode		
		0-0x7FFFFFFF	0x00000000	-	P		
PtP2.14	Control word of segment 107	Setting range	Default	Unit	Applicable mode		
		0-0x7FFFFFFF	0x00000000	-	P		
PtP2.16	Control word of segment 108	Setting range	Default	Unit	Applicable mode		
		0-0x7FFFFFFF	0x00000000	-	P		
PtP2.18	Control word of segment 109	Setting range	Default	Unit	Applicable mode		
		0-0x7FFFFFFF	0x00000000	-	P		
PtP2.20	Control word of segment 110	Setting range	Default	Unit	Applicable mode		
		0-0x7FFFFFFF	0x00000000	-	P		
PtP2.22	Control word of segment 111	Setting range	Default	Unit	Applicable mode		
		0-0x7FFFFFFF	0x00000000	-	P		

PtP2.24	Control word of segment 112	Setting range	Default	Unit	Applicable mode		
		0-0x7FFFFFFF	0x00000000	-	P		
PtP2.26	Control word of segment 113	Setting range	Default	Unit	Applicable mode		
		0-0x7FFFFFFF	0x00000000	-	P		
PtP2.28	Control word of segment 114	Setting range	Default	Unit	Applicable mode		
		0-0x7FFFFFFF	0x00000000	-	P		
PtP2.30	Control word of segment 115	Setting range	Default	Unit	Applicable mode		
		0-0x7FFFFFFF	0x00000000	-	P		
PtP2.32	Control word of segment 116	Setting range	Default	Unit	Applicable mode		
		0-0x7FFFFFFF	0x00000000	-	P		
PtP2.34	Control word of segment 117	Setting range	Default	Unit	Applicable mode		
		0-0x7FFFFFFF	0x00000000	-	P		
PtP2.36	Control word of segment 118	Setting range	Default	Unit	Applicable mode		
		0-0x7FFFFFFF	0x00000000	-	P		
PtP2.38	Control word of segment 119	Setting range	Default	Unit	Applicable mode		
		0-0x7FFFFFFF	0x00000000	-	P		
PtP2.40	Control word of segment 120	Setting range	Default	Unit	Applicable mode		
		0-0x7FFFFFFF	0x00000000	-	P		
PtP2.42	Control word of segment 121	Setting range	Default	Unit	Applicable mode		
		0-0x7FFFFFFF	0x00000000	-	P		
PtP2.44	Control word of segment 122	Setting range	Default	Unit	Applicable mode		
		0-0x7FFFFFFF	0x00000000	-	P		
PtP2.46	Control word of segment 123	Setting range	Default	Unit	Applicable mode		
		0-0x7FFFFFFF	0x00000000	-	P		
PtP2.48	Control word of segment 124	Setting range	Default	Unit	Applicable mode		
		0-0x7FFFFFFF	0x00000000	-	P		

PtP2.50	Control word of segment 125	Setting range	Default	Unit	Applicable mode		
		0-0x7FFFFFFF	0x00000000	-	P		
PtP2.52	Control word of segment 126	Setting range	Default	Unit	Applicable mode		
		0-0x7FFFFFFF	0x00000000	-	P		
PtP2.54	Control word of segment 127	Setting range	Default	Unit	Applicable mode		
		0-0x7FFFFFFF	0x00000000	-	P		

This group of parameter specifies the control words of segments 100 to 127. For details, see the description for PtP0.00.

PtP2.00	Data size	32bit	Data format	HEX
	Modbus address	3600, 3601	CANopen address	0x2D00, 0x00
PtP2.02	Data size	32bit	Data format	HEX
	Modbus address	3604, 3605	CANopen address	0x2D02, 0x00
PtP2.04	Data size	32bit	Data format	HEX
	Modbus address	3608, 3609	CANopen address	0x2D04, 0x00
PtP2.06	Data size	32bit	Data format	HEX
	Modbus address	3612, 3613	CANopen address	0x2D06, 0x00
PtP2.08	Data size	32bit	Data format	HEX
	Modbus address	3616, 3617	CANopen address	0x2D08, 0x00
PtP2.10	Data size	32bit	Data format	HEX
	Modbus address	3620, 3621	CANopen address	0x2D0A, 0x00
PtP2.12	Data size	32bit	Data format	HEX
	Modbus address	3624, 3625	CANopen address	0x2D0C, 0x00
PtP2.14	Data size	32bit	Data format	HEX
	Modbus address	3628, 3629	CANopen address	0x2D0E, 0x00
PtP2.16	Data size	32bit	Data format	HEX
	Modbus address	3632, 3633	CANopen address	0x2D10, 0x00
PtP2.18	Data size	32bit	Data format	HEX
	Modbus address	3636, 3637	CANopen address	0x2D12, 0x00
PtP2.20	Data size	32bit	Data format	HEX
	Modbus address	3640, 3641	CANopen address	0x2D14, 0x00
PtP2.22	Data size	32bit	Data format	HEX
	Modbus address	3644, 3645	CANopen address	0x2D16, 0x00
PtP2.24	Data size	32bit	Data format	HEX
	Modbus address	3648, 3649	CANopen address	0x2D18, 0x00

PtP2.26	Data size	32bit	Data format	HEX
	Modbus address	3652, 3653	CANopen address	0x2D1A, 0x00
PtP2.28	Data size	32bit	Data format	HEX
	Modbus address	3656, 3657	CANopen address	0x2D1C, 0x00
PtP2.30	Data size	32bit	Data format	HEX
	Modbus address	3660, 3661	CANopen address	0x2D1E, 0x00
PtP2.32	Data size	32bit	Data format	HEX
	Modbus address	3664, 3665	CANopen address	0x2D20, 0x00
PtP2.34	Data size	32bit	Data format	HEX
	Modbus address	3668, 3669	CANopen address	0x2D22, 0x00
PtP2.36	Data size	32bit	Data format	HEX
	Modbus address	3672, 3673	CANopen address	0x2D24, 0x00
PtP2.38	Data size	32bit	Data format	HEX
	Modbus address	3676, 3677	CANopen address	0x2D26, 0x00
PtP2.40	Data size	32bit	Data format	HEX
	Modbus address	3680, 3681	CANopen address	0x2D28, 0x00
PtP2.42	Data size	32bit	Data format	HEX
	Modbus address	3684, 3685	CANopen address	0x2D2A, 0x00
PtP2.44	Data size	32bit	Data format	HEX
	Modbus address	3688, 3689	CANopen address	0x2D2C, 0x00
PtP2.46	Data size	32bit	Data format	HEX
	Modbus address	3692, 3693	CANopen address	0x2D2E, 0x00
PtP2.48	Data size	32bit	Data format	HEX
	Modbus address	3696, 3697	CANopen address	0x2D30, 0x00
PtP2.50	Data size	32bit	Data format	HEX
	Modbus address	3700, 3701	CANopen address	0x2D32, 0x00
PtP2.52	Data size	32bit	Data format	HEX
	Modbus address	3704, 3705	CANopen address	0x2D34, 0x00
PtP2.54	Data size	32bit	Data format	HEX
	Modbus address	3708, 3709	CANopen address	0x2D36, 0x00

PtP2.01	Position of segment 100	Setting range	Default	Unit	Applicable mode		
		$-(2^{31}-1)-(2^{31}-1)$	0	reference unit	P		
PtP2.03	Position of segment 101	Setting range	Default	Unit	Applicable mode		
		$-(2^{31}-1)-(2^{31}-1)$	0	reference unit	P		

PtP2.05	Position of segment 102	Setting range	Default	Unit	Applicable mode		
		$-(2^{31}-1)-(2^{31}-1)$	0	reference unit	P		
PtP2.07	Position of segment 103	Setting range	Default	Unit	Applicable mode		
		$-(2^{31}-1)-(2^{31}-1)$	0	reference unit	P		
PtP2.09	Position of segment 104	Setting range	Default	Unit	Applicable mode		
		$-(2^{31}-1)-(2^{31}-1)$	0	reference unit	P		
PtP2.11	Position of segment 105	Setting range	Default	Unit	Applicable mode		
		$-(2^{31}-1)-(2^{31}-1)$	0	reference unit	P		
PtP2.13	Position of segment 106	Setting range	Default	Unit	Applicable mode		
		$-(2^{31}-1)-(2^{31}-1)$	0	reference unit	P		
PtP2.15	Position of segment 107	Setting range	Default	Unit	Applicable mode		
		$-(2^{31}-1)-(2^{31}-1)$	0	reference unit	P		
PtP2.17	Position of segment 108	Setting range	Default	Unit	Applicable mode		
		$-(2^{31}-1)-(2^{31}-1)$	0	reference unit	P		
PtP2.19	Position of segment 109	Setting range	Default	Unit	Applicable mode		
		$-(2^{31}-1)-(2^{31}-1)$	0	reference unit	P		
PtP2.21	Position of segment 110	Setting range	Default	Unit	Applicable mode		
		$-(2^{31}-1)-(2^{31}-1)$	0	reference unit	P		
PtP2.23	Position of segment 111	Setting range	Default	Unit	Applicable mode		
		$-(2^{31}-1)-(2^{31}-1)$	0	reference unit	P		
PtP2.25	Position of segment 112	Setting range	Default	Unit	Applicable mode		
		$-(2^{31}-1)-(2^{31}-1)$	0	reference unit	P		
PtP2.27	Position of segment 113	Setting range	Default	Unit	Applicable mode		
		$-(2^{31}-1)-(2^{31}-1)$	0	reference unit	P		

PtP2.29	Position of segment 114	Setting range	Default	Unit	Applicable mode		
		$-(2^{31}-1)-(2^{31}-1)$	0	reference unit	P		
PtP2.31	Position of segment 115	Setting range	Default	Unit	Applicable mode		
		$-(2^{31}-1)-(2^{31}-1)$	0	reference unit	P		
PtP2.33	Position of segment 116	Setting range	Default	Unit	Applicable mode		
		$-(2^{31}-1)-(2^{31}-1)$	0	reference unit	P		
PtP2.35	Position of segment 117	Setting range	Default	Unit	Applicable mode		
		$-(2^{31}-1)-(2^{31}-1)$	0	reference unit	P		
PtP2.37	Position of segment 118	Setting range	Default	Unit	Applicable mode		
		$-(2^{31}-1)-(2^{31}-1)$	0	reference unit	P		
PtP2.39	Position of segment 119	Setting range	Default	Unit	Applicable mode		
		$-(2^{31}-1)-(2^{31}-1)$	0	reference unit	P		
PtP2.41	Position of segment 120	Setting range	Default	Unit	Applicable mode		
		$-(2^{31}-1)-(2^{31}-1)$	0	reference unit	P		
PtP2.43	Position of segment 121	Setting range	Default	Unit	Applicable mode		
		$-(2^{31}-1)-(2^{31}-1)$	0	reference unit	P		
PtP2.45	Position of segment 122	Setting range	Default	Unit	Applicable mode		
		$-(2^{31}-1)-(2^{31}-1)$	0	reference unit	P		
PtP2.47	Position of segment 123	Setting range	Default	Unit	Applicable mode		
		$-(2^{31}-1)-(2^{31}-1)$	0	reference unit	P		
PtP2.49	Position of segment 124	Setting range	Default	Unit	Applicable mode		
		$-(2^{31}-1)-(2^{31}-1)$	0	reference unit	P		
PtP2.51	Position of segment 125	Setting range	Default	Unit	Applicable mode		
		$-(2^{31}-1)-(2^{31}-1)$	0	reference unit	P		

PtP2.53	Position of segment 126	Setting range	Default	Unit	Applicable mode		
		$-(2^{31}-1)-(2^{31}-1)$	0	reference unit	P		
PtP2.55	Position of segment 127	Setting range	Default	Unit	Applicable mode		
		$-(2^{31}-1)-(2^{31}-1)$	0	reference unit	P		
This group of parameter specifies the positions of segments 100 to 127. The CMD attribute determines the position command mode of a segment. P0.37 is inapplicable to this group.							
PtP2.01	Data size	32bit	Data format	DEC			
	Modbus address	3602, 3603	CANopen address	0x2D01, 0x00			
PtP2.03	Data size	32bit	Data format	DEC			
	Modbus address	3606, 3607	CANopen address	0x2D03, 0x00			
PtP2.05	Data size	32bit	Data format	DEC			
	Modbus address	3610, 3611	CANopen address	0x2D05, 0x00			
PtP2.07	Data size	32bit	Data format	DEC			
	Modbus address	3614, 3615	CANopen address	0x2D07, 0x00			
PtP2.09	Data size	32bit	Data format	DEC			
	Modbus address	3618, 3619	CANopen address	0x2D09, 0x00			
PtP2.11	Data size	32bit	Data format	DEC			
	Modbus address	3622, 3623	CANopen address	0x2D0B, 0x00			
PtP2.13	Data size	32bit	Data format	DEC			
	Modbus address	3626, 3627	CANopen address	0x2D0D, 0x00			
PtP2.15	Data size	32bit	Data format	DEC			
	Modbus address	3630, 3631	CANopen address	0x2D0F, 0x00			
PtP2.17	Data size	32bit	Data format	DEC			
	Modbus address	3634, 3635	CANopen address	0x2D11, 0x00			
PtP2.19	Data size	32bit	Data format	DEC			
	Modbus address	3638, 3639	CANopen address	0x2D13, 0x00			
PtP2.21	Data size	32bit	Data format	DEC			
	Modbus address	3642, 3643	CANopen address	0x2D15, 0x00			
PtP2.23	Data size	32bit	Data format	DEC			
	Modbus address	3646, 3647	CANopen address	0x2D17, 0x00			
PtP2.25	Data size	32bit	Data format	DEC			
	Modbus address	3650, 3651	CANopen address	0x2D19, 0x00			
PtP2.27	Data size	32bit	Data format	DEC			
	Modbus address	3654, 3655	CANopen address	0x2D1B, 0x00			
PtP2.29	Data size	32bit	Data format	DEC			

	Modbus address	3658, 3659	CANopen address	0x2D1D, 0x00
PtP2.31	Data size	32bit	Data format	DEC
	Modbus address	3662, 3663	CANopen address	0x2D1F, 0x00
PtP2.33	Data size	32bit	Data format	DEC
	Modbus address	3666, 3667	CANopen address	0x2D21, 0x00
PtP2.35	Data size	32bit	Data format	DEC
	Modbus address	3670, 3671	CANopen address	0x2D23, 0x00
PtP2.37	Data size	32bit	Data format	DEC
	Modbus address	3674, 3675	CANopen address	0x2D25, 0x00
PtP2.39	Data size	32bit	Data format	DEC
	Modbus address	3678, 3679	CANopen address	0x2D27, 0x00
PtP2.41	Data size	32bit	Data format	DEC
	Modbus address	3682, 3683	CANopen address	0x2D29, 0x00
PtP2.43	Data size	32bit	Data format	DEC
	Modbus address	3686, 3687	CANopen address	0x2D2B, 0x00
PtP2.45	Data size	32bit	Data format	DEC
	Modbus address	3690, 3691	CANopen address	0x2D2D, 0x00
PtP2.47	Data size	32bit	Data format	DEC
	Modbus address	3694, 3695	CANopen address	0x2D2F, 0x00
PtP2.49	Data size	32bit	Data format	DEC
	Modbus address	3698, 3699	CANopen address	0x2D31, 0x00
PtP2.51	Data size	32bit	Data format	DEC
	Modbus address	3702, 3703	CANopen address	0x2D33, 0x00
PtP2.53	Data size	32bit	Data format	DEC
	Modbus address	3706, 3707	CANopen address	0x2D35, 0x00
PtP2.55	Data size	32bit	Data format	DEC
	Modbus address	3710, 3711	CANopen address	0x2D37, 0x00

6.9 Status monitoring

6.9.1 System monitoring (group R0)

R0.00	Motor speed	Setting range	Accuracy	Unit
		-9999.9~9999.9	0.1	r/min
This parameter displays the actual oration speed of the motor.				
Note: Filtering is executed for the display.				
R0.00	Data size	32bit	Data format	DEC
	Modbus address	4000, 4001	CANopen address	0x3000, 0x00

R0.01	Speed command	Setting range	Accuracy	Unit
		-9999.9–9999.9	0.1	r/min

This parameter displays the current speed command of the servo motor.

Note: If the ACC/DEC time function is enabled, the command indicates the command that is executed after the ACC/DEC.

R0.01	Data size	32bit	Data format	DEC
	Modbus address	4002, 4003	CANopen address	0x3001, 0x00

R0.02	Accumulated feedback pulses	Setting range	Accuracy	Unit
		$-(2^{63}-1)-(2^{63}-1)$	1	reference unit

This parameter accumulates and displays the feedback pulses (with signs) of the servo motor.

R0.02	Data size	64bit	Data format	DEC
	Modbus address	4004, 4005, 4006, 4007	CANopen address	0x3002, 0x00 0x3002, 0x01

R0.03	Accumulated command pulses	Setting range	Accuracy	Unit
		$-(2^{63}-1)-(2^{63}-1)$	1	reference unit

This parameter accumulates and displays the position command pulses with signs.

R0.03	Data size	64bit	Data format	DEC
	Modbus address	4008, 4009, 4010, 4011	CANopen address	0x3003, 0x00 0x3003, 0x01

R0.04	Residual pulses	Setting range	Accuracy	Unit
		$-(2^{31}-1)-(2^{31}-1)$	1	reference unit

This parameter displays the residual pulses with signs of the position deviation counter.

R0.04	Data size	32bit	Data format	DEC
	Modbus address	4012, 4013	CANopen address	0x3004, 0x00

R0.05	Hybrid control deviation	Setting range	Accuracy	Unit
		$-(2^{31}-1)-(2^{31}-1)$	1	reference unit

This parameter displays the tolerance with a sign between the encoder feedback position and grating ruler feedback position when the fully-closed loop function is enabled.

R0.05	Data size	32bit	Data format	DEC
	Modbus address	4014, 4015	CANopen address	0x3005, 0x00

R0.06	Current torque	Setting range	Accuracy	Unit
		-500.0–500.0	0.1	%

This parameter displays the current torque, which is expressed in percentage, assuming the servo motor rated torque is 100.0%.

R0.06	Data size	16bit	Data format	DEC
	Modbus address	4016, 4017	CANopen address	0x3006, 0x00

R0.07	Main circuit DC voltage	Setting range	Accuracy	Unit
		0.0–1000.0	0.1	V

This parameter displays the DC bus voltage of the main circuit power.

R0.07	Data size	16bit	Data format	DEC
	Modbus address	4018, 4019	CANopen address	0x3007, 0x00

R0.09	Output voltage	Setting range	Accuracy	Unit
		0.0–1000.0	0.1	Vrms

This parameter displays the current output line voltage.

R0.09	Data size	16bit	Data format	DEC
	Modbus address	4022, 4023	CANopen address	0x3009, 0x00

R0.10	Output current	Setting range	Accuracy	Unit
		0.00–1000.00	0.01	Arms

This parameter displays the current output line current.

R0.10	Data size	32bit	Data format	DEC
	Modbus address	4024, 4025	CANopen address	0x300A, 0x00

R0.11	Drive temperature	Setting range	Accuracy	Unit
		-55.0–180.0	0.1	°C

This parameter displays the current temperature of the drive IGBT module.

R0.11	Data size	16bit	Data format	DEC
	Modbus address	4026, 4027	CANopen address	0x300B, 0x00

R0.12	Torque limit	Setting range	Accuracy	Unit
		-500.0–500.0	0.1	%

This parameter displays the actual torque limit, which is expressed in percentage, assuming the servo motor rated torque is 100.0%.

R0.12	Data size	16bit	Data format	DEC
	Modbus address	4028, 4029	CANopen address	0x300C, 0x00

R0.13	Encoder feedback value	Setting range	Accuracy	Unit
		0–(2 ³¹ -1)	1	pulse

This parameter displays the current feedback value of the encoder.

R0.13	Data size	32bit	Data format	DEC
	Modbus address	4030, 4031	CANopen address	0x300D, 0x00

R0.14	Rotor position relative to pulse Z	Setting range	Accuracy	Unit
		0–(2 ³¹ -1)	1	pulse

This parameter displays the absolute mechanical position of the motor in one encoder rotation cycle. The unit is encoder resolution.

R0.14	Data size	32bit	Data format	DEC
	Modbus address	4032, 4033	CANopen address	0x300E, 0x00

R0.15	Load inertia ratio	Setting range	Accuracy	Unit
		0–10000	1	%

This parameter displays the ratio of the load rotation inertia on the servo motor shaft to that on the servo motor.

R0.15	Data size	16bit	Data format	DEC
	Modbus address	4034, 4035	CANopen address	0x300F, 0x00

R0.16	Output power	Setting range	Accuracy	Unit
		-500.0–500.0	0.1	%

This parameter displays the current output mechanical power, which is expressed in percentage, assuming the servo motor rated power is 100%.

Note: A negative value indicates the motor is in power generation state.

R0.16	Data size	16bit	Data format	DEC
	Modbus address	4036, 4037	CANopen address	0x3010, 0x00

R0.17	Motor load ratio	Setting range	Accuracy	Unit
		0.0–500.0	0.1	%

This parameter displays the actual motor load ratio, which is expressed in percentage, assuming the servo motor rated power is 100%.

R0.17	Data size	16bit	Data format	DEC
	Modbus address	4038, 4039	CANopen address	0x3011, 0x00

R0.18	Numerator of actual electronic gear ratio	Setting range	Accuracy	Unit
		0–(2 ³¹ -1)	1	-

This parameter displays the numerator of the actual electronic gear ratio.

R0.18	Data size	32bit	Data format	DEC
	Modbus address	4040, 4041	CANopen address	0x3012, 0x00

R0.19	Denominator of actual electronic gear ratio	Setting range	Accuracy	Unit
		1-(2 ³¹ -1)	1	-
This parameter displays the denominator of actual electronic gear ratio.				
R0.19	Data size	32bit	Data format	DEC
	Modbus address	4042, 4043	CANopen address	0x3013, 0x00
R0.20	Position command speed	Setting range	Accuracy	Unit
		-9999.9-9999.9	0.1	r/min
This parameter displays the speed corresponding to a position command.				
R0.20	Data size	32bit	Data format	DEC
	Modbus address	4044, 4045	CANopen address	0x3014, 0x00
R0.21	Filtered motor speed	Setting range	Accuracy	Unit
		-9999.9-9999.9	0.1	r/min
This parameter displays the rotation speed that is used after filtering is executed for the servo motor.				
R0.21	Data size	32bit	Data format	DEC
	Modbus address	4046, 4047	CANopen address	0x3015, 0x00
R0.22	PTP status	Setting range	Accuracy	Unit
		-1-4223	1	-
This parameter displays the status of PTP control. The value -1 indicates PTP control is not executed. Any value from 0 to 127 indicates the number of segment that is being executed. A segment number plus 4096 indicates the current segment has been executed.				
R0.22	Data size	16bit	Data format	DEC
	Modbus address	4048, 4049	CANopen address	0x3016, 0x00
R0.23	Encoder absolute position feedback	Setting range	Accuracy	Unit
		-(2 ³¹ -1)-(2 ³¹ -1)	1	pulse
This parameter displays the encoder absolute position feedback. After absolute position clearing is executed, the setting of this parameter is 0.				
R0.23	Data size	32bit	Data format	DEC
	Modbus address	4050, 4051	CANopen address	0x3017, 0x00
R0.24	Encoder EEPROM status	Setting range	Accuracy	Unit
		0-3	-	-

This parameter displays the EEPROM status of the absolute encoder. If motor parameter data is not found in EEPROM or incorrect, the system uses the internal motor parameters of the drive.

Setting	Meaning
[0]	No EEPROM
1	No data found in the EEPROM
2	EEPROM data error
3	Data in the EEPROM is valid.

R0.24	Data size	16bit	Data format	DEC
	Modbus address	4052, 4053	CANopen address	0x3018, 0x00

R0.25	Turns of multiturn encoder	Setting range	Accuracy	Unit
		-32768~32767	1	-

This parameter displays the number of turns of the multiturn encoder.

R0.25	Data size	16bit	Data format	DEC
	Modbus address	4054, 4055	CANopen address	0x3019, 0x00

R0.26	Encoder type	Setting range	Accuracy	Unit
		0-6	-	-

This parameter displays the type of encoder supported by the hardware circuit.

Setting	Meaning
[3]	Photoelectric encoder
5	Rotary encoder
Other	Reserved

R0.26	Data size	16bit	Data format	DEC
	Modbus address	4056, 4057	CANopen address	0x301A, 0x00

R0.27	EtherCAT clock synchronization status	Setting range	Accuracy	Unit
		0-1	-	-

This parameter displays whether the drive internal clock has been synchronized with DC Sync0 in DC mode which is used for EtherCAT communication synchronization.

Setting	Meaning
[0]	Not synchronized
1	Synchronized

R0.27	Data size	16bit	Data format	DEC
	Modbus address	4058, 4059	CANopen address	0x301B, 0x00

R0.28	CANopen status machine	Setting range	Accuracy	Unit
		0-18	-	-

This parameter displays the current status of the internal CANopen status machine when CAN is used for communication or that of the CANopen over EtherCAT (CoE) status machine when EtherCAT is used for communication.

Setting	Protocol	Status
[0]	-	Invalid
1	CAN	Init
2		Pre-Op
5		Stop
8		Op (that is, Operational)
11	EtherCAT	Init
12		Pre-Op
14		Safe-Op
18		Op

R0.28	Data size	16bit	Data format	DEC
	Modbus address	4060, 4061	CANopen address	0x301C, 0x00

R0.30	System status	Setting range	Accuracy	Unit
		0-6	-	-

This parameter displays the system status of the drive.

Setting	Meaning
[0]	Initializing
1	Switching on strong current
2	Magnetic pole not determined
3	Ready
4	Bootstrapped charging
5	Running
6	Forced to stop
7	Faulty
8	STO-In

R0.30	Data size	16bit	Data format	DEC
	Modbus address	4064, 4065	CANopen address	0x301E, 0x00

R0.31	IGBT status	Setting range	Accuracy	Unit
		0-1	-	-

This parameter displays the IGBT status.

Setting	Meaning
[0]	Closed
1	Open

R0.31	Data size	16bit	Data format	DEC
	Modbus address	4066, 4067	CANopen address	0x301F, 0x00

R0.32	Current mode	Setting range	Accuracy	Unit
		0-2	-	-

This parameter displays the control mode that the drive uses currently.

Setting	Meaning
[0]	Position mode
1	Speed mode
2	Torque mode

R0.32	Data size	16bit	Data format	DEC
	Modbus address	4068, 4069	CANopen address	0x3020, 0x00

R0.33	Power-on time	Setting range	Accuracy	Unit
		0-(2 ³¹ -1)	1	s

This parameter displays the total power-on time used by the drive.

R0.33	Data size	32bit	Data format	DEC
	Modbus address	4070, 4071	CANopen address	0x3021, 0x00

R0.34	Enabling time	Setting range	Accuracy	Unit
		0-(2 ³¹ -1)	1	s

This parameter displays the time used by the drive to enable the servo.

R0.34	Data size	32bit	Data format	DEC
	Modbus address	4072, 4073	CANopen address	0x3022, 0x00

R0.35	DSP version no.	Setting range	Accuracy	Unit
		0.00-10.00	0.01	-

This parameter displays the DSP version number.

R0.35	Data size	16bit	Data format	DEC
	Modbus address	4074, 4075	CANopen address	0x3023, 0x00

R0.36	FPGA version no.	Setting range	Accuracy	Unit
		0.00-10.00	0.01	-

This parameter displays the current FPGA version number.

R0.36	Data size	16bit	Data format	DEC
	Modbus address	4076, 4077	CANopen address	0x3024, 0x00

R0.38	Drive SN 1	Setting range	Accuracy	Unit
		0-65535	1	-

This parameter displays drive series number 1.

R0.38	Data size	16bit	Data format	DEC
	Modbus address	4080, 4081	CANopen address	0x3026, 0x00

R0.39	Drive SN 2	Setting range	Accuracy	Unit
		0-65535	1	-

This parameter displays drive series number 2.

R0.39	Data size	16bit	Data format	DEC
	Modbus address	4082, 4083	CANopen address	0x3027, 0x00

R0.40	Drive SN 3	Setting range	Accuracy	Unit
		0-65535	1	-

This parameter displays drive series number 3.

R0.40	Data size	16bit	Data format	DEC
	Modbus address	4084, 4085	CANopen address	0x3028, 0x00

R0.41	Drive SN 4	Setting range	Accuracy	Unit
		0-65535	1	-

This parameter displays drive series number 4.

R0.41	Data size	16bit	Data format	DEC
	Modbus address	4086, 4087	CANopen address	0x3029, 0x00

R0.42	Drive SN 5	Setting range	Accuracy	Unit
		0-65535	1	-

This parameter displays drive series number 5.

R0.42	Data size	16bit	Data format	DEC
	Modbus address	4088, 4089	CANopen address	0x302A, 0x00

R0.43	Drive SN 6	Setting range	Accuracy	Unit
		0-65535	1	-

This parameter displays drive series number 6.

R0.43	Data size	16bit	Data format	DEC
	Modbus address	4090, 4091	CANopen address	0x302B, 0x00

R0.44	Absolute position in single grating ruler (or encoder 2) turn	Setting range	Accuracy	Unit
		0–(2 ³¹ -1)	1	pulse
This parameter displays the feedback of the absolute position in a single turn of the grating ruler (or second encoder).				
R0.44	Data size	32bit	Data format	DEC
	Modbus address	4092, 4093	CANopen address	0x302C, 0x00
R0.45	Speed feedback from encoder 2	Setting range	Accuracy	Unit
		-9999.9–9999.9	0.1	r/min
This parameter displays the actual speed of the servo motor.				
R0.45	Data size	32bit	Data format	DEC
	Modbus address	4094, 4095	CANopen address	0x302D, 0x00
R0.46	Speed observer detection	Setting range	Accuracy	Unit
		-9999.9–9999.9	0.1	r/min
This parameter displays the detected speed from the speed observer.				
R0.46	Data size	32bit	Data format	DEC
	Modbus address	4096, 4097	CANopen address	0x302E, 0x00
R0.47	Speed observer feedback	Setting range	Accuracy	Unit
		-9999.9–9999.9	0.1	r/min
This parameter displays the feedback speed from the speed observer.				
R0.47	Data size	32bit	Data format	DEC
	Modbus address	4098, 4099	CANopen address	0x302F, 0x00
R0.48	Torque from disturbance observer	Setting range	Accuracy	Unit
		-1000.0–1000.0	0.1	%
This parameter displays the compensation torque from the disturbance observer.				
R0.48	Data size	32bit	Data format	DEC
	Modbus address	4100, 4101	CANopen address	0x3030, 0x00
R0.49	Fully-closed loop vibration suppressor compensation	Setting range	Accuracy	Unit
		-9999.9–9999.9	0.1	r/min
This parameter displays the compensation from the fully-closed loop vibration suppressor.				
R0.49	Data size	32bit	Data format	DEC
	Modbus address	4102, 4103	CANopen address	0x3031, 0x00

R0.51	Real-time load inertia ratio	Setting range	Accuracy	Unit
		0-10000	1	%

This parameter displays the load inertia ratio observed in real time.

R0.51	Data size	16bit	Data format	DEC
	Modbus address	4106, 4107	CANopen address	0x3033, 0x00

R0.52	Accumulated grating ruler (or encoder 2) position feedback (32-bit)	Setting range	Accuracy	Unit
		$-(2^{31}-1)-(2^{31}-1)$	1	pulse

This parameter accumulates and displays the 32-bit absolute position feedback from the grating ruler (or second encoder). It can be read quickly. If the feedback exceeds 32 bits, it is replaced by R0.57.

R0.52	Data size	32bit	Data format	DEC
	Modbus address	4108, 4109	CANopen address	0x3034, 0x00

R0.53	Gantry synchronization position deviation	Setting range	Accuracy	Unit
		$-(2^{31}-1)-(2^{31}-1)$	1	reference unit

This parameter displays the gantry synchronization position deviation.

R0.53	Data size	32bit	Data format	DEC
	Modbus address	4110, 4111	CANopen address	0x3035, 0x00

R0.54	Grating ruler (or encoder 2) position feedback	Setting range	Accuracy	Unit
		$0-(2^{31}-1)$	1	pulse

This parameter displays the position feedback from the grating ruler (or second encoder).

R0.54	Data size	32bit	Data format	DEC
	Modbus address	4112, 4113	CANopen address	0x3036, 0x00

R0.55	Encoder turn deviation after multiturn position cleared	Setting range	Accuracy	Unit
		$-(2^{31}-1)-(2^{31}-1)$	1	-

This parameter displays the encoder turn deviation after multiturn positions are cleared.

R0.55	Data size	32bit	Data format	DEC
	Modbus address	4114, 4115	CANopen address	0x3037, 0x00

R0.56	Encoder feedback deviation after multiturn	Setting range	Accuracy	Unit
		$-(2^{31}-1)-(2^{31}-1)$	1	pulse

	position cleared			
This parameter displays the encoder feedback deviation after multiturn positions are cleared.				
R0.56	Data size	32bit	Data format	DEC
	Modbus address	4116, 4117	CANopen address	0x3038, 0x00

R0.57	Accumulated grating ruler (or encoder 2) position feedback (64-bit)	Setting range	Accuracy	Unit
		$-(2^{63}-1)-(2^{63}-1)$	1	pulse
This parameter accumulates and displays the 64-bit absolute position feedback from the grating ruler (or second encoder).				
R0.57	Data size	64bit	Data format	DEC
	Modbus address	4118, 4119, 4120, 4121	CANopen address	0x3039, 0x00 0x3039, 0x01

R0.60	Medium-power motor temperature	Setting range	Accuracy	Unit
		-55–200	1	°C
This parameter displays the current temperature of the medium-power motor with temperature resistor KTY84-130. Temperature is sampled only when P4.45 is not zero.				
R0.60	Data size	32bit	Data format	DEC
	Modbus address	4126, 4127	CANopen address	0x303C, 0x00

R0.99	Fault code	Setting range	Accuracy	Unit
		-32768–32767	1	-
This parameter displays the fault code, in which the thousands and hundreds digits are the main fault code and the tens and ones digits are the sub fault code.				
R0.99	Data size	16bit	Data format	DEC
	Modbus address	4198, 4199	CANopen address	0x3063, 0x00

6.9.2 I/O monitoring (group R1)

R1.00	Digital input status	Setting range	Accuracy	Unit
		0x000–0x3FF	-	-
R1.01	Digital output status	Setting range	Accuracy	Unit
		0x00–0x3F	-	-

Each of the parameters is a hexadecimal number, indicating the status of all digital terminals in sequence. The terminal status ON is expressed by 1, while the terminal status OFF is expressed by 0. Then the decimal number is converted to a hexadecimal number.

The digital input status is expressed by a three-bit hexadecimal number. The sorting order of digital input is as follows:

(The bits not listed are padded with 0.)

BIT9	BIT8	BIT7	BIT6	BIT5	BIT4	BIT3	BIT2	BIT1	BIT0
SI10	SI9	SI8	SI7	SI6	SI5	SI4	SI3	SI2	SI1

The digital output status is expressed by a two-bit hexadecimal number. The sorting order of digital output is as follows:

(The bits not listed are padded with 0.)

BIT5	BIT4	BIT3	BIT2	BIT1	BIT0
SO6	SO5	SO4	SO3	SO2	SO1

R1.00	Data size	16bit	Data format	HEX
	Modbus address	4200, 4201	CANopen address	0x3100, 0x00
R1.01	Data size	16bit	Data format	HEX
	Modbus address	4202, 4203	CANopen address	0x3101, 0x00

R1.02	Raw voltage of AI 1	Setting range	Accuracy	Unit
		-10.000–10.000	0.001	V

This parameter displays the unprocessed voltage of the analog input channel 1.

R1.02	Data size	32bit	Data format	DEC
	Modbus address	4204, 4205	CANopen address	0x3102, 0x00

R1.03	Raw voltage of AI 2	Setting range	Accuracy	Unit
		-10.000–10.000	0.001	V

This parameter displays the unprocessed voltage of the analog input channel 2.

R1.03	Data size	32bit	Data format	DEC
	Modbus address	4206, 4207	CANopen address	0x3103, 0x00

R1.05	Corrected voltage of AI 1	Setting range	Accuracy	Unit
		-10.000–10.000	0.001	V

This parameter displays the corrected voltage of the analog input channel 1.

R1.05	Data size	32bit	Data format	DEC
	Modbus address	4210, 4211	CANopen address	0x3105, 0x00

R1.06	Corrected voltage of AI 2	Setting range	Accuracy	Unit
		-10.000–10.000	0.001	V
This parameter displays the corrected voltage of the analog input channel 2.				
R1.06	Data size	32bit	Data format	DEC
	Modbus address	4212, 4213	CANopen address	0x3106, 0x00
R1.08	Voltage of AO 1	Setting range	Accuracy	Unit
		-10.000–10.000	0.001	V
This parameter displays the biased voltage of the analog output channel 1.				
R1.08	Data size	32bit	Data format	DEC
	Modbus address	4216, 4217	CANopen address	0x3108, 0x00
R1.09	Voltage of AO 2	Setting range	Accuracy	Unit
		-10.000–10.000	0.001	V
This parameter displays the biased voltage of the analog output channel 2.				
R1.09	Data size	32bit	Data format	DEC
	Modbus address	4218, 4219	CANopen address	0x3109, 0x00
R1.11	Accumulated input pulses	Setting range	Accuracy	Unit
		$-(2^{31}-1)-(2^{31}-1)$	1	reference unit
This parameter accumulates and displays the number of pulses that are received from the external pulse input.				
R1.11	Data size	32bit	Data format	DEC
	Modbus address	4222, 4223	CANopen address	0x310B, 0x00
R1.12	Pulse position command	Setting range	Accuracy	Unit
		$-(2^{31}-1)-(2^{31}-1)$	1	reference unit
This parameter displays the position command value in each pulse input detection cycle (0.125ms by default).				
R1.12	Data size	32bit	Data format	DEC
	Modbus address	4224, 4225	CANopen address	0x310C, 0x00
R1.13	Pulse-corresponded speed command	Setting range	Accuracy	Unit
		-10000.0–10000.0	0.1	r/min
This parameter displays the speed command corresponding to the pulse position command.				
R1.13	Data size	32bit	Data format	DEC
	Modbus address	4226, 4227	CANopen address	0x310D, 0x00

R1.14	Analog compensation speed	Setting range	Accuracy	Unit
		-10000.0–10000.0	0.1	r/min
This parameter displays the analog compensation speed.				
R1.14	Data size	32bit	Data format	DEC
	Modbus address	4228, 4229	CANopen address	0x310E, 0x00

R1.15	Analog compensation torque	Setting range	Accuracy	Unit
		-1000.0–1000.0	0.1	%
This parameter displays the analog compensation torque.				
R1.15	Data size	32bit	Data format	DEC
	Modbus address	4230, 4231	CANopen address	0x310F, 0x00

R1.16	DI-captured encoder value	Setting range	Accuracy	Unit
		$-(2^{31}-1)$ – $(2^{31}-1)$	1	pulse
This parameter displays the encoder value captured through DI input.				
R1.16	Data size	32bit	Data format	DEC
	Modbus address	4232, 4233	CANopen address	0x3110, 0x00

6.9.3 Fault recording (group R3)

R3.00	Fault code	Setting range	Accuracy	Unit
		-	-	-
This parameter displays the code of the currently-read fault record. It contains the information on the last fault by default.				

R3.01	Power-on time before fault	Setting range	Accuracy	Unit
		$0-(2^{31}-1)$	1	h
This parameter displays the time used for power-on before the currently-read fault occurred.				

R3.02	Running time before fault	Setting range	Accuracy	Unit
		$0-(2^{31}-1)$	1	h
This parameter displays the running time before the currently-read fault occurred.				

R3.03	Motor speed before fault	Setting range	Accuracy	Unit
		-20000–20000	1	r/min
This parameter displays the motor speed before the currently-read fault occurred.				

R3.04	Speed command before fault	Setting range	Accuracy	Unit
		-20000–20000	1	r/min
This parameter displays the speed command before the fault occurred.				

R3.05	Accumulated feedback pulses before fault	Setting range	Accuracy	Unit
		$-(2^{63}-1)-(2^{63}-1)$	1	reference unit

This parameter displays the feedback pulses that are accumulated before the currently-read fault occurred.

R3.06	Accumulated command pulses before fault	Setting range	Accuracy	Unit
		$-(2^{63}-1)-(2^{63}-1)$	1	reference unit

This parameter displays the command pulses that are accumulated before the currently-read fault occurred.

R3.07	Residual pulses before fault	Setting range	Accuracy	Unit
		$-(2^{31}-1)-(2^{31}-1)$	1	reference unit

This parameter displays the residual pulses before the currently-read fault occurred.

R3.08	Output torque before fault	Setting range	Accuracy	Unit
		-500.0–500.0	0.1	%

This parameter displays the torque output before the currently-read fault occurred.

R3.09	Main circuit DC voltage before fault	Setting range	Accuracy	Unit
		0.0–1000.0	0.1	V

This parameter displays the main-circuit DC voltage before the currently-read fault occurred.

R3.10	Output voltage before fault	Setting range	Accuracy	Unit
		0.0–1000.0	0.1	Vrms

This parameter displays the drive output line voltage before the currently-read fault occurred.

R3.11	Output current before fault	Setting range	Accuracy	Unit
		0.00–1000.00	0.01	Arms

This parameter displays the drive output line current before the currently-read fault occurred.

R3.20	Last fault code	Setting range	Accuracy	Unit
		-	-	-

This parameter displays the code of the last fault.

R3.21	2nd-last fault code	Setting range	Accuracy	Unit
		-	-	-

This parameter displays the code of the second-last fault.

R3.22	3rd-last fault code	Setting range	Accuracy	Unit
		-	-	-
This parameter displays the code of the third-last fault.				

R3.23	4th-last fault code	Setting range	Accuracy	Unit
		-	-	-
This parameter displays the code of the fourth-last fault.				

R3.24	5th-last fault code	Setting range	Accuracy	Unit
		-	-	-
This parameter displays the code of the fifth-last fault.				

R3.25	6th-last fault code	Setting range	Accuracy	Unit
		-	-	-
This parameter displays the code of the sixth-last fault.				

R3.26	7th-last fault code	Setting range	Accuracy	Unit
		-	-	-
This parameter displays the code of the seventh-last fault.				

R3.27	8th-last fault code	Setting range	Accuracy	Unit
		-	-	-
This parameter displays the code of the eighth-last fault.				

R3.28	9th-last fault code	Setting range	Accuracy	Unit
		-	-	-
This parameter displays the code of the ninth-last fault.				

R3.29	10th-last fault code	Setting range	Accuracy	Unit
		-	-	-
This parameter displays the code of the tenth-last fault.				

7

Commissioning

7.1 Instructions on identifying inertia238

7.2 General methods for adjusting parameters239

 7.2.1 Adjusting gains in position mode241

 7.2.2 Adjusting gains in speed mode242

 7.2.3 Adjusting gains in torque mode243

7.3 Mechanical resonance suppressing244

7.4 Gains switching245

7.1 Instructions on identifying inertia

Inertia can be identified online or offline.

Identifying inertia online

Before selecting online inertia identifying, you must set the parameters P1.00 [Tune inertia online] and P1.08 [Inertia identifying class].

The online identifying mode is valid when P1.00 and P1.08 are greater than 0. If the following inertia identifying conditions are met:

- The speed is higher than 150 r/min.
- The ACC time is greater than 20ms.
- The continuous ACC range exceeds 150 r/min.
- The ACC is reached within 0.3s (from 0 r/min to 3000 r/min).

The inertia identifying result is automatically updated to P1.01 [Inertia ratio 1] and written to the EEPROM at an interval of 30 minutes.

Identifying inertia offline

Before selecting offline inertia identifying, you must set the parameters P1.05 [Inertia identifying mode], P1.06 [Max. rotations by inertia identifying], and P1.07 [ACC time for inertia identifying]. You can enable offline inertia identifying by using the auxiliary function EF-JId on the panel. For details, see section 5.2.5.5 "Inertia identifying". Offline inertia identifying is not affected by P1.00 [Tune inertia online] and P1.08 [Inertia identifying class].

Before enabling the auxiliary function EF-JId, set P1.05 based on the motor allowed running mode, P1.06 based on the motor allowed rotations, and P1.07 based on the mechanical rigidity. Strong mechanical rigidity allows you to set a small ACC/DEC time constant. P1.05 can be set to 1 indicating forward rotating or 2 reverse rotating. If P1.06 is set to a greater value while P1.07 is set to a smaller value, the inertia identifying result is more accurate.

In addition, ensure the settings of P1.05 and P1.06 are compliant with the mechanical structure. Otherwise, mechanical damage may be caused. During the execution, you can press the **Mode** key to terminate.

If the auxiliary function EF-JId is executed successfully, the identifying result is automatically saved to P1.01 [Inertia ratio 1]. If a fault occurred during the identifying, P1.01 keeps the previous setting. If fault Er25-7 [Inertia identifying failed] is reported, try to set P1.06 to a greater value or P1.07 to a smaller value.

If the following occurs onsite:

- Low mechanical rigidity
- Sharp change on load inertia
- Non-linear characteristics such as clearance
- Sudden change on external disturbance

The inertia identifying result accuracy is impacted.

7.2 General methods for adjusting parameters

DA180 servo drive parameters can be adjusted by two methods.

Automatic adjusting

You need to evaluate the load inertia ratio manually and set the servo system rigidity, which has 32 options from 0 to 31. Then different loop gains can be set automatically.

This method features quick adjusting servo system responsiveness.

Adjust the system rigidity based on the actual situation. The recommended rigidity settings are as follows:

Mechanical structure	Rigidity
Large transfer or transmission equipment	0–13
Belt drive mechanism	5–16
Ball screw + belt drive	5–16
Manipulator	15–22
Direct ball screw or rigid body	18–25

A greater rigidity value indicates quicker response, but it increases the possibility to cause noise and vibration. You need to check the mechanical device actions before the setting.

If the setting cannot meet your requirements, use manual adjusting.

Manual adjusting

If the servo system encounters vibration or control performance cannot meet requirements, you can adjust speed loop and position loop parameters to eliminate vibration or improve performance.

You can adjust the following parameters manually:

- Speed loop gain: It determines the response speed of the speed loop. If the mechanical system has no vibration, a greater speed loop gain indicates a quicker response speed.
- Speed loop integral time constant: The speed loop contains the integral component, which can respond to minor input. The integral component may delay servo system jobs. A greater time constant indicates slower response, increasing positioning time. If load inertia is heavy or servo system has a great possibility to encounter vibration, this time constant must be great. Otherwise, the servo system may encounter vibration.
- Torque command filtering: The mechanical system may encounter resonance, which causes sharp vibration noise. At this time, you must use the notch filter to eliminate resonance.
- APS gain: It determines the servo system responsiveness. A greater APS gain indicates a quicker response speed, reducing positioning time. If you need to set the gain to a great value, the rigidity and natural frequency of the mechanical system must be high.

Generally, the speed loop gain must be greater than the position loop gain. If the position loop gain is much greater than the speed loop, the system may be overshoot with the function of step signals, therefore deteriorating system performance. System parameters are restricted mutually. If only the position loop gain is increased, the commands output from the position loop may be unstable, which

may cause unstable responsiveness of the entire servo system. Perform adjusting in the following sequence:

1. Set the position loop gain to a small value and increase it to a value as large as possible without causing abnormal noise or vibration.
2. Decrease the speed loop gain gradually and increase the position loop gain as much as allowed without causing overshooting or vibration.
3. Decrease the speed loop integral time constant as much as possible without causing vibration since this time constant is determined by positioning time.
4. Adjust the position loop gain, speed loop gain, and speed loop integral time constant slightly to achieve optimum settings.

The following describes typical adjusting cases (in the cases except case 1, only one parameter needs to be adjusted):

- Appropriate parameter settings

In this case, parameters are set appropriately, the motor speed is compliant with the position command, the speed is not overshoot, and positioning time is short.

- Speed loop integral time constant too small

The servo drive speed loop must respond quickly. If the speed fluctuates, the speed loop integral time constant is too small, which deteriorates the speed loop stability. Therefore, the running is unstable.

- Speed loop integral time constant too large

The difference from the case of appropriate parameter settings is not noticeable. The speed loop integral has no significant impact when the speed follows up the position command, but the response time of the speed loop is impacted if the speed loop integral time constant is too large.

- Speed loop gain too high

In this case, the motor speed fluctuates. If the speed loop integral time is too short, the similar impact is caused. You must increase both the speed loop gain and the speed loop integral time. Otherwise, the servo system may encounter vibration.

- Speed loop gain too low

If the speed loop gain is decreased, the motor speed fluctuates. According to the comparison the case of speed loop gain too large, the fluctuation frequency of the motor speed is lower in this case, which indicates that increasing the speed loop gain improves the system working frequency, control system responsiveness, and anti-interference.

- Position loop gain too low

In the servo system, the working frequency of the position loop is lower than that of the speed loop. If the position loop gain is too low, the system cannot counteract the position deviation that is caused during speed responding, which delays the interval at which the motor speed follows up the position command.

- Position loop gain too high

In the position servo system, the position loop gain also impacts stability. If the position loop gain is too high, the motor speed fluctuates. According to the comparison with the case of position loop gain too low, the delay with which the motor speed follows up the position command is decreased in this case.

- Position loop gain too low

If the position loop gain is too low, the motor speed lags behind the position command noticeably, and positioning time is prolonged. The accuracy and response performance of the positioning system are impacted seriously.

7.2.1 Adjusting gains in position mode

The common procedure for adjusting parameters in position mode is as follows:

1. Restore default settings.

For details, see section 5.2.5.3 "Factory parameter restoring".

2. Adjust the position loop gain.

If the servo motor runs with default settings but the system vibrates with buzzes, decrease the position loop gain (that is, P2.02 or P2.07) or increase it when the system rigidity is low.

3. Adjust the position smoothing filter.

In position control, if the input frequency changes of position pulse commands are noticeable, huge surges may be caused. You need to adjust the P0.33 [Position command smooth filter time] or P0.34 [Position command FIR filter time].

4. Adjust the electronic gear.

If the pulse generation device is limited on the pulse sending frequency or the sending frequency does not meet mechanical requirements, you can change the pulse input frequency by adjusting P0.22 [Pulses per motor resolution] or electronic gear ratio parameters P0.25, P0.26, P0.27, P0.28, and P0.29, so as to meet position control requirements.

5. Adjust the position feed-forward.

If the residual pulses are great or no-deviation tracking is required, you can adjust the speed feed-forward gain parameter P2.10 and speed feed-forward filtering parameter P2.11 to improve position tracking performance. However, if the speed feed-forward gain is too large, the system may vibrate.

6. Set the frequency division for feedback pulse output.

If feedback pulses need to be output, you can set the frequency-division output coefficient parameters P0.06 and P0.07 to change the pulse output frequency.

7.2.2 Adjusting gains in speed mode

The following block diagram illustrates speed control for DA180 servo drive and lists the adjustable gain parameters in this control mode.

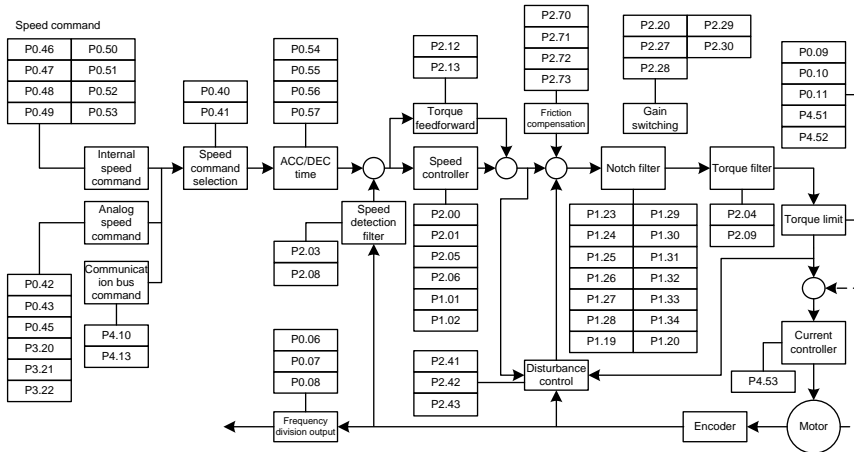

The common procedure for adjusting parameters in speed mode is as follows:

1. Restore default settings.

For details, see section 5.2.5.3 "Factory parameter restoring".

2. Adjust the speed loop gain.

If the servo motor runs with default settings but the system vibrates with buzzes, you need to decrease the speed loop gain (that is, P2.00 or P2.05) or increase it when the system rigidity is low or the speed fluctuates sharply.

3. Adjust the speed integral time constant.

If the speed loop gain is increased, you need to increase the speed integral time constant (that is, P2.01 or P2.06) as well. Conversely, if the speed loop gain is decreased, you need to decrease the speed integral time constant as well.

4. Adjust the ACC/DEC time.

If the speed in the starting process changes sharply, huge surges or overcurrent may be caused. You need to adjust P0.54 [ACC time] to smooth the ramp-up. Similarly, you can adjust P0.55 [DEC time] to smooth the ramp-down for the stop.

5. Adjust the S-curve ACC/DEC time.

If the speed change cannot be smoothed by adjusting the ACC or DEC time, you can adjust P0.56 [S-curve ACC time] or P0.57 [S-curve DEC time].

6. Adjust the speed smoothing filter.

If the analog input is a speed command, you can adjust the analog input filter to smooth the speed change.

7. Adjust the speed feed-forward.

If the speed tracking performance is not improved after the parameter adjusting, you can adjust P2.12 [Torque feed-forward gain] and P2.13 [Torque feed-forward filter time] to improve it. However, if the torque feed-forward gain is too high, the system may become unstable.

8. Adjust time filtering.

You can improve speed loop performance by adjusting the torque filter parameters P2.04 and P2.09 and speed detection filter parameters P2.03 and P2.08.

9. Adjust notch filtering.

For details, see section 7.3 "Mechanical resonance suppressing".

10. Set the frequency division for feedback pulse output.

If the encoder feedback pulse signal needs to be output, you can set the frequency-division output coefficient parameters P0.06 and P0.07 to change the pulse output frequency.

11. Adjust disturbance suppression.

If the load change is noticeable or sudden external disturbance on the torque occurred when the gain settings are small, you can adjust P2.42 [Disturbance observer compensation gain] and P2.43 [Disturbance observer cut-off frequency] to reduce the impact by external disturbance, so as to improve speed loop performance.

12. Adjust friction compensation.

If the speed follow-up performance is poor in the process of the motor changing the direction for forward or reverse rotating, you can adjust P2.71 [CCW torque coefficient of friction compensation] and P2.72 [CW torque coefficient of friction compensation] to improve speed loop performance in the process.

7.2.3 Adjusting gains in torque mode

The following block diagram illustrates torque control for DA180 servo drive and lists the adjustable gain parameters in torque control mode.

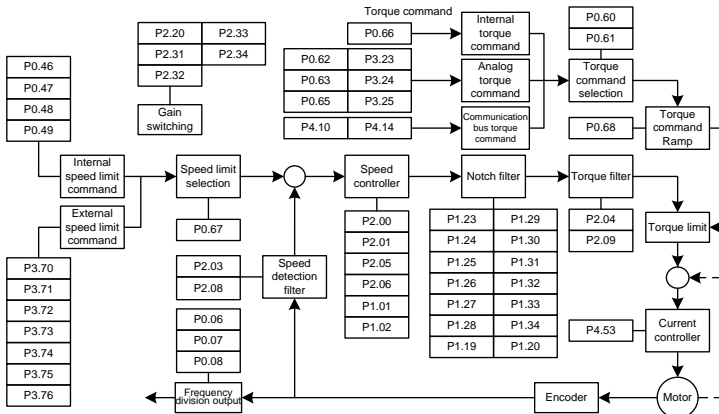

The common procedure for adjusting parameters in speed mode is as follows:

1. Restore default settings.

For details, see section 5.2.5.3 "Factory parameter restoring".

2. Adjust the torque smoothing filter.

If the analog input is a torque command, you can adjust the torque smoothing filter to smooth the torque change.

3. Set the frequency division for feedback pulse output.

If the encoder feedback pulse signal needs to be output, you can set the frequency-division output coefficient parameters P0.06 and P0.07 to change the pulse output frequency.

7.3 Mechanical resonance suppressing

The mechanical system resonates at a certain frequency. If a high servo response speed is set when the mechanical rigidity is low, the shaft torsion may cause resonance (including vibration and abnormal noise) near the mechanical resonant frequency. At this situation, you can set notch filter parameters to effectively suppress mechanical resonance.

A notch filter can suppress the mechanical resonance peak by reducing the gain at certain frequency. You can set notch filter parameters to suppress the resonant frequency, width, and depth, so as for the system to obtain higher gains or reduce vibration.

The servo driver has been equipped with four notch filters, which are specified by the first notch filter parameters P1.23, P1.24, and P1.25, second notch filter parameters P1.26, P1.27, and P1.28, third notch filter parameters P1.29, P1.30, and P1.31, and fourth notch filter parameters P1.32, P1.33, and P1.34 respectively.

Note: The notch filters are a lagging factor for the servo system. If the center frequency of a notch filter is incorrectly set or the suppression depth is too large, the vibration may be stronger. You are

recommended to gradually increase the depth (the parameter setting changes from large to small) until requirements are met.

The relationship between the Q factor, width, and depth of a notch filter is as follows:

- Q factor of notch filter = Center frequency of notch filter/Bandwidth of notch filter
- The width of the notch filter indicates the frequency difference between the -3dB-dropped power spectrums at the two sides of the center frequency when the depth of the notch filter is 0.
- The depth of the notch filter indicates the ratio of input to output. The power spectrum strength is attenuated by $20 \log(P1.25\%, P1.28\%, P1.31\%, P1.34\%)$ dB.

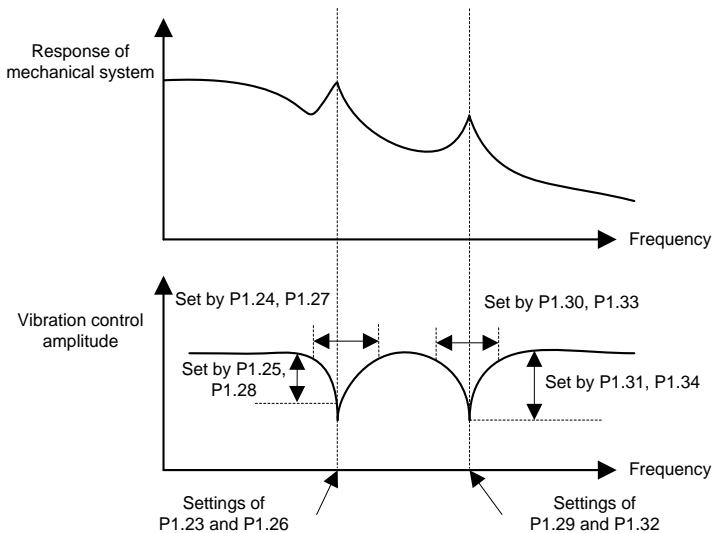

7.4 Gains switching

Gains can be switched through internal data or external signals to:

- Control motor vibration if the gain is reduced during stop.
- Shorten tuning and positioning time if the gain is increased during stop.
- Improve command follow-up and speed if the gain is increased during working.
- Control gain switching through external signals based on external status of device.

In the following tables of switching gains in different modes, ● indicates the parameter is valid while – indicates the parameter is invalid.

Position control and fully-closed loop control

Trigger			Settings for position/fully-closed-loop control		
P2.22	To switch to gain 2	Figure	Delay time* ¹	Level	Lag* ²
			P2.23	P2.24	P2.25
0	Fixed to gain 1		-	-	-
1	Fixed to gain 2		-	-	-
2	With gain switching input		-	-	-
3	Torque command too large	1	●	●(0.1%)	●(0.1%)
4	Speed command too large	3	●	●(r/min)	●(r/min)
5	Position deviation too large	4	●	●* ³ (reference unit)	●* ³ (reference unit)
6	With position command input	5	●	-	-
7	Positioning incomplete	6	●	-	-
8	Actual speed too high	3	●	●(r/min)	●(r/min)
9	Position command + actual speed	7	●	●(r/min)* ⁵	●(r/min)* ⁵

Speed control

Trigger			Settings for speed control		
P2.27	To switch to gain 2	Figure	Delay time* ¹	Level	Lag* ²
			P2.28	P2.29	P2.30
0	Fixed to gain 1		-	-	-
1	Fixed to gain 2		-	-	-
2	With gain switching input		-	-	-
3	Torque command input	1	●	●(0.1%)	●(0.1%)
4	Torque command variable input	2	-	●* ⁴ (10(r/min)/s)	●* ⁴ (10(r/min)/s)
5	Speed command	3	●	●(r/min)	●(r/min)

Torque control

Trigger			Settings for torque control		
P2.31	To switch to gain 2	Figure	Delay time* ¹	Level	Lag* ²
			P2.32	P2.33	P2.34
0	Fixed to gain 1		-	-	-
1	Fixed to gain 2		-	-	-
2	With gain switching input		-	-	-
3	Torque command input	1	●	●(0.1%)	●(0.1%)

Remarks:

*¹: The delay time parameters P2.23, P2.28, and P2.32 are valid only when the second gain is switched back the first gain.

*²: See the following figure to understand the lag parameters P2.25, P2.30, and P2.34.

*³: The resolution of the encoder or external grating ruler is specified through the control mode.

*⁴: The setting is 1 if a speed change of 10 r/min occurs within 1s.

*⁵: When P2.22 is set to 9, the meanings of delay time, level, and lag are different to the common ones.

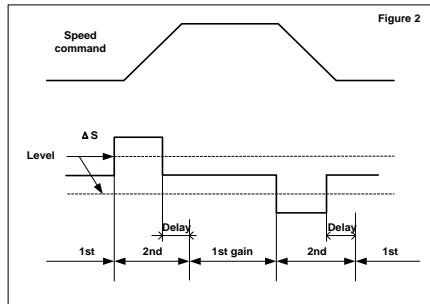
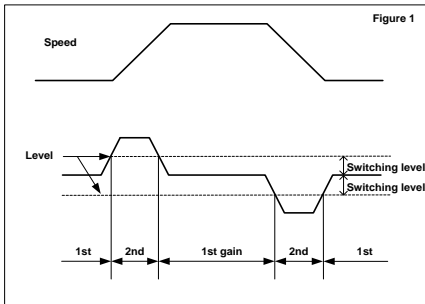
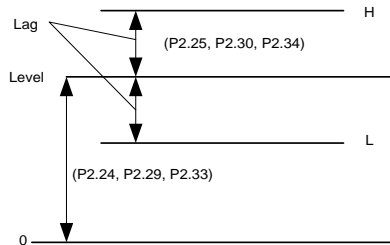

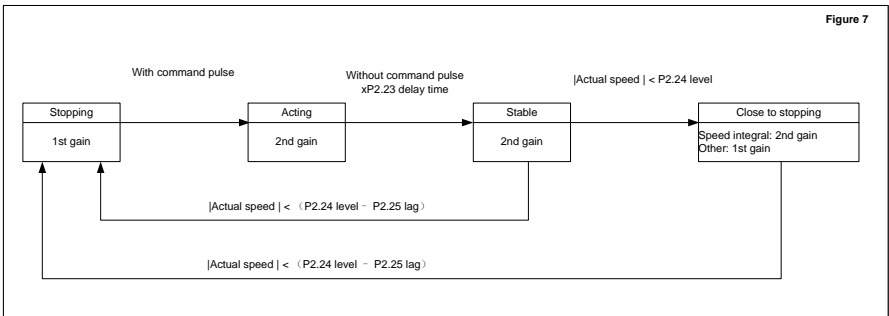
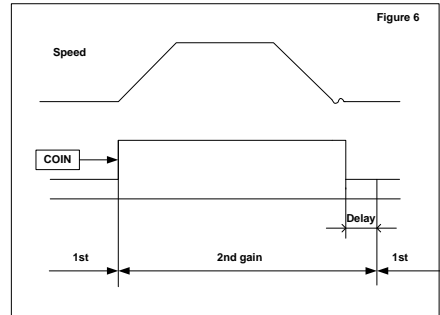
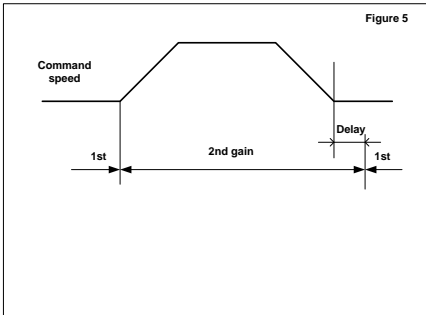
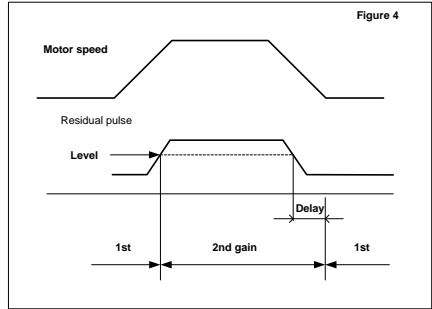
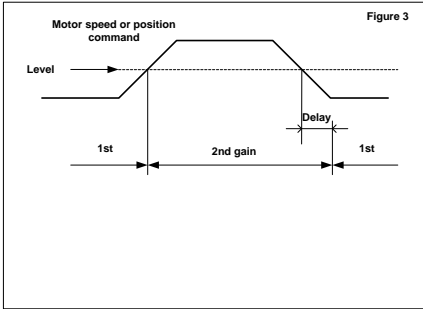

Note: The preceding figures do not illustrate the gain-switching timing sequence offset caused by lag parameters P2.25, P2.30, and P2.34.

8**Communication**

8.1 General description	250
8.2 RS485	250
8.2.1 Modbus protocol description	250
8.2.2 Protocol application	250
8.2.3 Communication frame structure	251
8.2.4 Command codes	251
8.2.5 Checking for communication frame errors	253
8.2.6 Responding to errors	254
8.3 CANopen	255
8.3.1 Protocol description	255
8.3.2 Hardware configuration	255
8.3.3 Software configuration	255
8.3.4 Supported functions	256
8.4 Upper computer software	262
8.4.1 ServoPlover	262
8.4.2 Hardware	262
8.4.3 Software	262
8.4.4 Communication connection	262
8.4.5 Installing and running	263
8.4.6 Program interface	264
8.4.7 Setting parameters	264
8.4.8 Using the help manual	265
8.4.9 Using the oscilloscope	265

8.1 General description

DA180 servo drive provides RS485 and CANopen interfaces to communicate with the upper computer NC or PLC. The NC or PLC can implement asynchronous serial half-duplex communication with 31 servo drivers simultaneously through the RS485 interface or with 127 servo drivers simultaneously through the CAN interface to:

- Read servo drive function parameters
- Monitor drive servo working status
- Form a multi-shaft control system

DA180 servo drive provides the USB and CANopen interfaces to communicate with the PC. Thus, the PC uses either of the interfaces to calibrate the parameter settings, monitor status, and read data from and write data to the servo driver.

8.2 RS485

DA180 servo drive provides the RS485 communication interface, which uses the standard Modbus communication protocol to implement master/slave communication. You can implement integrated control on the PC, PLC, or upper computer to meet specific application requirements. Integrated control includes setting servo drive control commands, running frequency, function codes, and working status, and monitoring fault information.

8.2.1 Modbus protocol description

The Modbus serial communication protocol defines the frame content and formats asynchronously transferred. The formats include those for master-node polling, broadcast frames, and slave-node response frames. The content of a frame sent from the master node includes the slave-device address (or broadcast address), execution command, data, and error checking. The response from a slave node is structured similarly to a frame sent from the master node. The response content includes action confirmation, data returning, and error checking. If a slave node encountered an error in receiving frames or failed completing the action required by the master node, the slave node sends back a fault frame as response to the master node.

8.2.2 Protocol application

DA180 servo drive uses the asynchronous serial master/slave Modbus communication protocol, which indicates only one device (that is, master node) in the network can establish protocols (called "queries/commands"). The other devices (that is, slave nodes) can only provide data response to or react according to the "queries/commands" from the master node. The master node herein indicates the PC, industrial control device, or PLC, while slave nodes indicate DA180 servo drive or control devices with the same communication protocol. The master node can not only communicate with one

slave node but also send broadcast message to all. For a separate "query/command" from the master node, the slave node must return a response message; for a broadcast message from the master node, slave nodes do not need to respond.

8.2.3 Communication frame structure

Modbus supports the RTU transmission mode only. You can set the serial-port communication parameters (including the baud rate and check method). In an RTU message frame, each 8-bit byte consists of two 4-bit hexadecimal characters.

Table 8-1 RTU message frame

Start bit	Device address	Command	Data	CRC	Stop bit
T1-T2-T3-T4	8Bit	8Bit	n * 8 bits	16Bit	T1-T2-T3-T4

In this mode, each message must be preceded by a time gap with a minimum length of 3.5 characters. During the transmission, the network device continuously detects the network bus even within the time gap. When the first domain (or address domain) is received, the corresponding device decodes the subsequent transmission characters. The message ends only when there is a time gap with a minimum length of 3.5 characters.

An entire RTU message frame must be transmitted as a continuous flow. If a receiver detects a time gap with a minimum length of 1.5 characters before the frame ends, the receiver refreshes the incomplete message and assumes that the next byte is the address domain of a new message. Similarly, if a new message follows the previous message within the time gap with a length of less than 3.5 characters, the receivers considers the new message as the continuity to the previous message. If either of the case occurs, a CRC error message is generated and sent back to the sender.

8.2.4 Command codes

8.2.4.1 Command code 03H

Function: to read n words (a maximum of 16 words can be read continuously)

Example: If the command is to continuously read two words from the memory start address 03F2H of the servo drive with the slave-node address 01H, the command frame structure is as follows:

Table 8-2 Master-node command message

START	T1-T2-T3-T4 (3.5-byte transmission time)
ADDR	01H
CMD	03H
Read MSB in start address	03H
Read LSB in start address	F2H
MSB of data count (in word)	00H
LSB of data count (in word)	02H

CRC CHK LSB	65H
CRC CHK MSB	BCH
END	T1-T2-T3-T4 (3.5-byte transmission time)

Table 8-3 Slave-node response message

START	T1-T2-T3-T4 (3.5-byte transmission time)
ADDR	01H
CMD	03H
Number of bytes	04H
Content MSB of start address 03F2H	00H
Content LSB of start address 03F2H	C8H
Content MSB of 2nd address 03F3H	00H
Content LSB of 2nd address 03F3H	00H
CRC CHK LSB	7BH
CRC CHK MSB	CDH
END	T1-T2-T3-T4 (3.5-byte transmission time)

8.2.4.2 Command code 10H

Function: to read n words ($n \geq 2$)

Example: If the command is to write 300 (0000012CH) to the address 03F2H of the servo drive with the slave-node address 01H, the command frame structure is as follows:

Table 8-4 Master-node command message

START	T1-T2-T3-T4 (3.5-byte transmission time)
ADDR	01H
CMD	10H
Write MSB of data address	03H
Write LSB of data address	F2H
MSB of data count (in word)	00H
LSB of data count (in word)	02H
Byte count	04H
MSB of word 1 in data content	01H
LSB of word 1 in data content	2CH
MSB of word 2 in data content	00H
LSB of word 2 in data content	00H
CRC CHK LSB	A9H
CRC CHK MSB	F7H
END	T1-T2-T3-T4 (3.5-byte transmission time)

Table 8-5 Slave-node response message

START	T1-T2-T3-T4 (3.5-byte transmission time)
ADDR	01H
CMD	10H
Write MSB of data start address	03H
Write LSB of data start address	F2H
MSB of data count (in word)	00H
LSB of data count (in word)	02H
CRC CHK LSB	E0H
CRC CHK MSB	7FH
END	T1-T2-T3-T4 (3.5-byte transmission time)

8.2.5 Checking for communication frame errors

Checking for communication frame errors consists of bit checking (that is, parity checking) for bytes and entire-data checking (that is, CRC or LRC) for frames.

8.2.5.1 Bit checking for bytes

You can select different methods or even no checking based on your requirements, which affects the check bit setting of each byte.

Even parity: An even parity bit is added before data transmission, indicating the number of 1 in the transmitted data is even or odd. If the number is even, the parity bit is 0. Otherwise, the parity bit is 1.

Odd parity: An odd parity bit is added before data transmission, indicating the number of 1 in the transmitted data is even or odd. If the number is odd, the parity bit is 0. Otherwise, the parity bit is 1.

Example: The number 11001110 is to be transmitted: If even parity is used, the even parity bit is 1; if odd parity is used, the odd parity bit is 0. During transmission, the even/odd parity bit is placed in the parity check position after calculation.

8.2.5.2 Cyclical Redundancy Check (CRC)

An RTU frame includes the domain for checking for errors in the entire frame using the CRC method. This CRC domain consists of two bytes, including 16-bit hexadecimals. It is added to the frame after being calculated by the sender. The receiver recalculates the CRC in the received frame and compares it with the value in the received CRC domain. If the CRC values are different, a transmission error occurred.

Before CRC, 0xFFFF is stored to the register, and then a process is invoked to compare the successive 6 bytes or more with the values in the register. Only when the 8-bit data in each character is valid to CRC, the start bit, stop bit, and parity bit are invalid.

During CRC generation, each 8-bit character has an independent exclusive or relationship with register content. The comparison result moves towards the LSB direction, and 0 is padded to the

MSB. Then the LSB is extracted for detection. If the LSB is 1, the register and preset value have an independent exclusive or relationship. If the LSB is not 0, there is no such a relationship. The processing is repeated eight times. When the eighth bit of the current character is checked, the next each 8-bit character is checked for an independent exclusive or relationship with register content. Finally, register content is the CRC values for all characters in the frame.

This CRC calculation method is compliant with international standards. When editing the CRC calculation method, you can see the standards.

8.2.6 Responding to errors

A slave device responds with a function code field and fault address to specify whether the response is normal (that is, no error occurred) or abnormal (that is, an error occurred). In a normal response, the slave node responds with the function code and data address or sub function code. In an abnormal response, the slave node responds with a code that equals a normal code but starts with logic 1.

For example, if the master node sends a request to a slave node to read the address data of a group of servo drive function code, the following function code is generated:

0 0 0 0 0 1 1 (Hexadecimal 03H)

In a normal response, the slave node responds with the same function code. In an abnormal response, the slave node returns:

1 0 0 0 0 1 1 (Hexadecimal 83H)

In addition to the function code that is modified due to the error, the slave node returns an error code, indicating the error cause.

After receiving the abnormal response, the master node resends a message, which is typical processing, or it changes the command based on the error.

Table 8-6 Error codes

Modbus error codes		
Code	Function	Meaning
01H	Invalid function	The function code that the upper computer receives is not allowed for operation. The possible cause is that the function code is applicable to new devices only or that the slave node handles such a request in abnormal state.
02H	Invalid data address	The data address requested by the upper computer is not allowed by the servo drive. Especially, the register address and transmitted byte combination are invalid.
03H	Invalid data value	The received data is not within the address range, which cause invalidity of parameter modification.

Modbus error codes		
Code	Function	Meaning
11H	Check error	The check error message is reported when the CRC bit in RTU format or LRC bit in ASCII format in the frame message sent from the upper computer is different from the checking count number on the lower device.

8.3 CANopen

8.3.1 Protocol description

CANopen is a high-layer communication protocol structured over the Control Area Network (CAN). It includes the communication profiles and device profiles for embedded systems. It is also an onsite bus widely used in industrial control. Common CANopen devices and communication profiles are defined in CAN in Automation (CiA) draft standard 301. Based on CiA 301, other profiles are developed for special devices, such as CiA 402 for motion control.

8.3.2 Hardware configuration

For details on the pin definitions and functions of the CAN communication terminal CN3, see section 3.6 "Wiring for RS485/CAN terminal CN3".

The following table lists the mapping between baud rates and maximum transmission lengths.

Baud rate	Communication length
1Mbit/s	25m
500kbit/s (by default)	100m
250kbit/s	250m
125kbit/s	500m
50kbit/s	1000m
20kbit/s	2500m

Note:

- The CANL and CANH pins of all slave nodes can be directly connected in serial model, but not star model.
- A 120 ohms resistor must be connected between the master node and final node of the slave node.
- Shielded twisted pairs are recommended as CAN connection cables for anti-interference.
- A longer connection cable indicates a higher requirement on CAN chip drive ability.

8.3.3 Software configuration

Before CANopen is enabled for DA180 servo drive, you must:

1. Set P0.03 [Control mode] to 7 [CANopen mode] on the LED panel or through ServoPlover.
 2. Set P4.02 [CAN baud rate] on the LED panel or through ServoPlover.
- P4.02 can be set to 0 (1 Mbps), 1 (500 kbps), 2 (250 kbps), 3 (125 kbps), 4 (50 kbps), or 5 (20 kbps).

3. Set P4.05 [CAN node no.] on the LED panel or through ServoPlover.

P4.05 can be set to an integer ranging from 1 to 127.

Note:

- For all of the three parameters, you must repower the drive or perform soft reset for the parameter modification to take effect.
- Each node number must be unique, regardless of whether the node is master or slave.
- Synchronization signals are generated from the master node in most cases but can be generated from slave nodes through configuration. The communication synchronization interval is 1 us, while the minimum interval supported by DA180 servo drive is 1000us (that is, 1ms).
- When the master node requires a slave node to send heartbeat packets, the parameter 0x1017 must be set in 1ms.
- When the CANopen status machine exits from the OP state, the servo drive automatically shuts down for safety.

8.3.4 Supported functions

As a standard slave CANopen node, DA180 servo drive supports certain parameters for CiA 301 and CiA 402.

The basic CANopen protocols supported include NMT, SYNC, SDO, PDO, and EMCY.

The predefined connection set defines four Receive-PDOs, four Transmit-PDOs, one SDO (occupying two CAN-IDs), one emergency object, and one Node-Error-Control ID. The servo drive also supports the NMT-Module-Control service that needs no confirmation and broadcast of SYNC objects.

Table 8-7 CiA 402 protocol parameters supported by the servo drive

Index	Object type	Name	Data type	Access	Mappable
6040 _n	VAR	Control word	UNSIGNED16	RW	Y
6041 _n	VAR	Status word	UNSIGNED16	RO	Y
6042 _n	VAR	vl target velocity	INTEGER16	RW	Y
6043 _n	VAR	vl velocity demand	INTEGER16	RO	Y
6044 _n	VAR	vl control effort	INTEGER16	RO	Y
6046 _n	ARRAY	vl velocity min max amount	UNSIGNED32	RW	Y
6047 _n	ARRAY	vl velocity min max	UNSIGNED32	RW	Y
6048 _n	RECORD	vl velocity acceleration	UNSIGNED32	RW	Y
6049 _n	RECORD	vl velocity deceleration	UNSIGNED32	RW	Y
6060 _n	VAR	Mode of operation	INTEGER8	RW	Y
6061 _n	VAR	Mode of operation display	INTEGER8	RO	Y

Index	Object type	Name	Data type	Access	Mappable
6062 _n	VAR	Position demand value	INTEGER32	RO	Y
6063 _n	VAR	Position actual value*	INTEGER32	RO	Y
6064 _n	VAR	Position actual value	INTEGER32	RO	Y
6065 _n	VAR	Following error window	UNSIGNED32	RW	Y
6066 _n	VAR	Following error time out	UNSIGNED16	RW	Y
6067 _n	VAR	Position window	UNSIGNED32	RW	Y
6069 _n	VAR	Velocity sensor actual value	INTEGER32	RO	Y
606B _n	VAR	Velocity demand value	INTEGER32	RO	Y
606C _n	VAR	Velocity actual value	INTEGER32	RO	Y
606D _n	VAR	Velocity window	UNSIGNED16	RW	Y
606F _n	VAR	Velocity threshold	UNSIGNED16	RW	Y
6071 _n	VAR	Target torque	INTEGER16	RW	Y
6072 _n	VAR	Max torque	UNSIGNED16	RW	Y
6073 _n	VAR	Max current	UNSIGNED16	RO	Y
6074 _n	VAR	Torque demand value	INTEGER16	RO	Y
6075 _n	VAR	Motor rated current	UNSIGNED32	RO	Y
6076 _n	VAR	Motor rated torque	UNSIGNED32	RO	Y
6077 _n	VAR	Torque actual value	INTEGER16	RO	Y
6078 _n	VAR	Current actual value	INTEGER16	RO	Y
6079 _n	VAR	DC link circuit voltage	UNSIGNED32	RO	Y
607A _n	VAR	Target position	INTEGER32	RW	Y
607C _n	VAR	Home offset	INTEGER32	RW	Y
607D _n	ARRAY	Software position limit	INTEGER32	RW	Y
6080 _n	VAR	Max motor speed	UNSIGNED32	RW	Y
6081 _n	VAR	Profile velocity	UNSIGNED32	RW	Y
6083 _n	VAR	Profile acceleration	UNSIGNED32	RW	Y
6084 _n	VAR	Profile deceleration	UNSIGNED32	RW	Y
6085 _n	VAR	Quick stop deceleration	UNSIGNED32	RW	Y
6086 _n	VAR	Motion profile type	INTEGER16	RO	Y
6087 _n	VAR	Torque slope	UNSIGNED32	RW	Y
6088 _n	VAR	Torque profile type	INTEGER16	RO	Y
6093 _n	ARRAY	Position factor	UNSIGNED32	RW	Y
6098 _n	VAR	Homing method	INTEGER8	RW	Y

Index	Object type	Name	Data type	Access	Mappable
6099 _n	ARRAY	Homing speeds	UNSIGNED32	RW	Y
60C0 _n	VAR	Interpolation sub mode select	INTEGER16	RO	Y
60C1 _n	ARRAY	Interpolation data record	INTEGER32	RW	Y
60C2 _n	RECORD	Interpolation time period	INTEGER8	RW	Y
60F4 _n	VAR	Following error actual value	INTEGER32	RO	Y
60F8 _n	VAR	Max slippage	INTEGER32	RW	Y
60FA _n	VAR	Control effort	INTEGER32	RO	Y
60FC _n	VAR	Position demand value*	INTEGER32	RO	Y
60FD _n	VAR	Digital inputs	UNSIGNED32	RO	Y
60FE _n	ARRAY	Digital outputs	UNSIGNED32	RO	Y
60FF _n	VAR	Target velocity	INTEGER32	RW	Y

Table 8-8 CANopen fault codes

Display	Fault name	32-bit fault code (16-bit error code + 16-bit additional information)
Er01-0	IGBT fault	2320-0100h
Er01-5	IPM fault	2334-0105h
Er02-0	Encoder fault–Encoder communication exception	7301-0200h
Er02-1	Encoder fault–Encoder feedback deviation too large	7300-0201h
Er02-2	Encoder fault– Parity error	7300-0202h
Er02-3	Encoder fault–CRC error	7300-0203h
Er02-4	Encoder fault–Frame error	7300-0204h
Er02-5	Encoder fault–Short frame error	7300-0205h
Er02-6	Encoder fault–Encoder exception reporting	7305-0206h
Er02-7	Encoder fault–Second-encoder timeout	7306-0207h
Er02-8	Encoder fault–Encoder battery low-voltage alarm	5114-0208h
Er02-9	Encoder fault–Encoder battery undervoltage fault	5115-0209h
Er02-a	Encoder fault–Encoder overheating	7300-020ah

Display	Fault name	32-bit fault code (16-bit error code + 16-bit additional information)
Er02-b	Encoder fault–Encoder EEPROM writing error	7300-020bh
Er02-c	Encoder fault–No data in encoder EEPROM	7300-020ch
Er02-d	Encoder fault–Encoder EEPROM data check error	7300-020dh
Er03-0	Current sensor fault–Phase-U current sensor fault	7200-0300h
Er03-1	Current sensor fault–Phase-V current sensor fault	7200-0301h
Er03-2	Current sensor fault–Phase-W current sensor fault	7200-0302h
Er04-0	System initialization fault	6100-0400h
Er05-1	Setting fault–Motor model not exist	6320-0501h
Er05-2	Setting fault–Motor and drive model not match	6320-0502h
Er05-3	Setting fault–Incorrect software limits	6320-0503h
Er05-4	Setting fault–Incorrect homing mode	6320-0504h
Er05-5	Setting fault–PTP-control travel overflow	6320-0505h
Er07-0	Regeneration discharge overload fault	7112-0700h
Er08-0	AI overvoltage fault–AI 1	7200-0800h
Er08-1	AI overvoltage fault–AI 2	7200-0801h
Er09-0	EEPROM fault–Read/write error	5520-900h
Er09-1	EEPROM fault–Data check error	5530-0901h
Er10-0	Hardware fault–FPGA fault	7400-1000h
Er10-1	Communication card fault	7500-1001h
Er10-2	Hardware fault–Ground short-connection fault	2300-1002h
Er10-3	Hardware fault–External input fault	5430-1003h
Er10-4	Hardware fault–Emergency stop fault	5430-1004h
Er10-5	Hardware fault–RS485 communication fault	7500-1005h

Display	Fault name	32-bit fault code (16-bit error code + 16-bit additional information)
Er10-6	Hardware fault–AC power phase loss	7500-1006h
Er11-0	Software fault–Motor control task re-entry	6100-1100h
Er11-1	Software fault–Periodic task re-entry	6100-1101h
Er11-2	Software fault–Illegal operation	6100-1102h
Er12-0	I/O fault–Duplicate digital input assignment	6320-1200h
Er12-2	I/O fault–Pulse input frequency too high	5430-1202h
Er13-0	Main circuit overvoltage	3110-1300h
Er13-1	Main circuit undervoltage	3120-1301h
Er14-0	Control power undervoltage	5200-0E00h
Er17-0	Drive overload	3230-1700h
Er17-1	Drive overload 2	3230-1701h
Er18-0	Motor overload	3230-1800h
Er18-1	Motor overtemperature	3230-1801h
Er19-0	Speed fault–Overspeed	8400-1900h
Er19-1	Speed fault–CCW overspeed	8400-1901h
Er19-2	Speed fault–CW overspeed	8400-1902h
Er19-3	Speed fault–Overspeed parameter set incorrectly	6320-1903h
Er19-4	Speed fault–Motor runaway fault	8400-1904h
Er20-0	Speed deviation fault	8400-2000h
Er21-0	Position overtravel–CCW	8500-2100h
Er21-1	Position overtravel–CW	8500-2101h
Er22-0	Position deviation fault	8611-2200h
Er22-1	Hybrid control deviation too large	8611-2201h
Er22-2	Position increment overflow	8611-2202h
Er22-3	CANopen fault–Synchronization signal timeout	8611-2203h
Er22-4	CANopen fault–Full position command buffer	7500-2204h
Er23-0	Drive overtemperature	4201-2300h

Display	Fault name	32-bit fault code (16-bit error code + 16-bit additional information)
Er25-4	Application fault–Encoder offset angle test timeout	ff00-2504h
Er25-5	Application fault–Encoder offset angle test failed	ff00-2505h
Er25-6	Application fault–Homing offside	ff00-2506h
Er25-7	Application fault–Inertia identifying failed	ff00-2507h
Er25-8	Application fault–Magnetic pole detection failure	ff00-2508h
Er25-9	Application fault–Overtravel or overspeed in acknowledgement of magnetic pole detection	ff00-2509h
Er25-a	Application fault–Out of the range of magnetic pole detection	ff00-250ah
Er26-0	CANopen fault–CANopen offline	8100-2600h
Er26-1	CANopen fault–SDO index not exist	8100-2601h
Er26-2	CANopen fault–SDO sub-index not exist	8100-2602h
Er26-3	CANopen fault–Incorrect SDO data length	8100-2603h
Er26-4	CANopen fault–SDO data out of range	8100-2604h
Er26-5	CANopen fault–Modification not allowed for read-only	8100-2605h
Er26-6	CANopen fault–Incorrect PDO mapping length	8100-2606h
Er26-7	CANopen fault–PDO mapping data not exist	8100-2607h
Er26-8	CANopen fault–PDO modification not allowed in operational state	8100-2608h
Er26-9	CANopen fault–PDO mapping not allowed	8100-2609h
Er26-a	CANopen fault–Synchronization signal too fast	8100-260ah
Er26-b	CANopen fault–Receiving fault	8100-260bh
Er26-c	CANopen fault–Sending fault	8100-260ch

Display	Fault name	32-bit fault code (16-bit error code + 16-bit additional information)
Er26-d	CANopen fault–Duplicate synchronization signal	8100-260dh
Er26-e	CANopen fault–Bus load ratio too high	8100-260eh
Er26-f	CANopen fault–Incorrect parameter modification status	8100-260fh

8.4 Upper computer software

8.4.1 ServoPlorer

ServoPlorer is the upper computer software for monitoring and commissioning DA180 servo driver. It can:

- Monitor drive status parameters in real time.
- Modify drive parameters online.
- Support USB communication, and monitor the waveforms through four channels in real time with a minimum resolution of 0.125ms.
- Save parameters to files in batches and download them to the servo driver in batches.
- Display and read faults.
- Provide independent function application interfaces (such as for frequency feature testing, inertia identifying, jogging, and electronic cams)

8.4.2 Hardware

CPU	Pentium 4 or later
Memory	1G or greater
Hard disk	512M or greater
Screen resolution	1024×768 or higher
Communication interface	USB1.1

8.4.3 Software

Operating system	Windows XP, Vista, Windows7
.NET version	.NET Framework 4.0
Excel version	Excel 2007, 2010 or later

8.4.4 Communication connection

The servo driver can connect to a computer through the USB interface. See the following for the connection.

Cable type	Appearance	Description
Mini-USB cable	Standard Mini-USB cable 	After the servo drive is powered on, you can connect the servo drive to the computer through the USB cable and install the designated the USB driver program.

8.4.5 Installing and running

To download INVT ServoPlover V4.0, visit www.invt.com, choose **Service and Support > Data Download**, and enter keywords for search. During the installing, the installer automatically checks whether plug-ins need to be installed on your computer and displays messages. Before using ServoPlover, ensure the software and hardware configuration on your computer meets the requirements in 8.4.2 "Hardware" and 8.4.3 "Software".

The USB driver program is located under the software installation directory (relative path: ...\\ServoPlover\\Drive\\USB drive\\). If the driver program needs to be installed manually, perform the following steps:

1. Double click **My computer**, choose **Hardware device manager > Update drive program**, locate the directory for storing the program, and run the file as highlighted in red in the following figure.

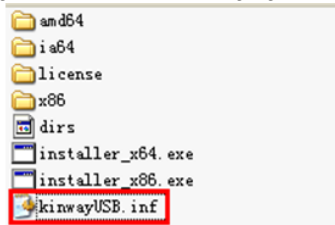

To start ServoPlover, double click **ServoPlover.exe** in the installation directory, as shown in the following figure:

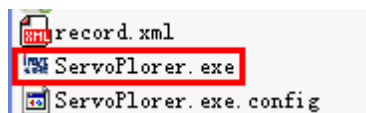

After the startup is complete, the following interface is displayed:



8.4.6 Program interface

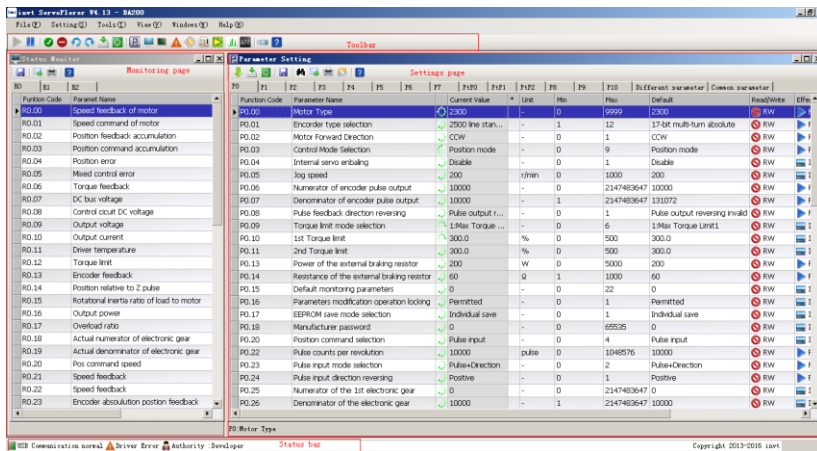

The program interface consists of:

- Menu bar and toolbar, entries to sub-interfaces and functions
- Status monitoring area on the left, which displays the real-time feedback of status parameters
- Parameter setting area on the right, used to modify parameters
- Status bar, used to display the current communication mode and status, fault status, and user permissions.

8.4.7 Setting parameters

To set a parameter, do as follows:

1. In the parameter setting area on the right, locate the row where the parameter resides.
2. Double click the value of the parameter. If you have the permission, enter or select a proper value in the modification box.
3. Use either of the following methods to send the modification to the servo drive:

- Press **Enter** in the editing window.
- Click the sending button  on the toolbar.



8.4.8 Using the help manual

ServoPlover is embedded with a .chm help manual, which provides software use instructions and describes parameters. You can click the help button to obtain help information.

The main interface provides a general entry to the help manual, while the help button in each window enables you to go to the mapping help information.

8.4.9 Using the oscilloscope

You can enable the oscilloscope by clicking the oscilloscope button on the toolbar or choosing **Tool > Oscilloscope** from the menu bar.

Oscilloscope interface

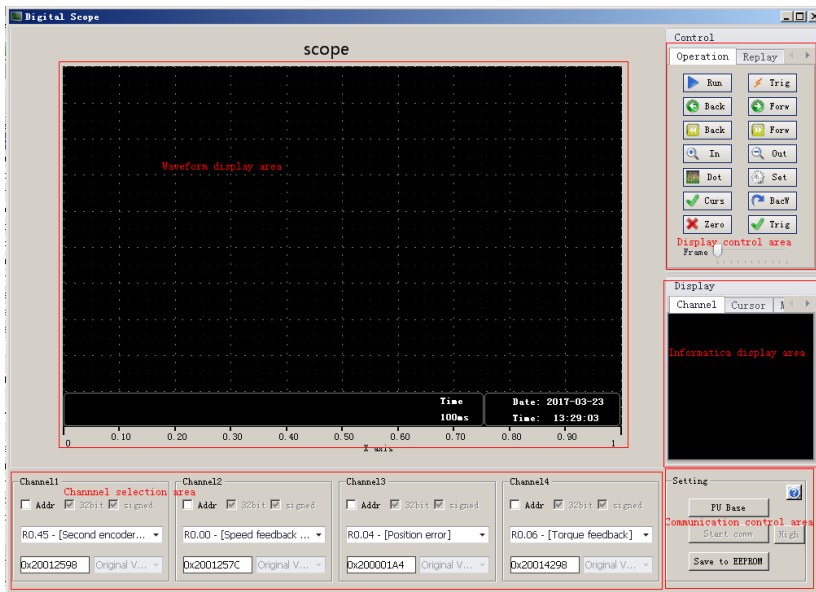

The oscilloscope interface consists of:

- Waveform display area: enables you to draw waveforms and auxiliary display elements, such as cursor and gain information.
- Channel selection area: enables you to select the content to be monitored through a channel, supporting selection by parameter function code or variable internal address.

- Display control area
 - Operation tab: enables you to start and stop the drawing of waveforms, forward, reverse, zoom in, and zoom out the oscilloscope, control the cursor, and display trigger thresholds.
 - Playback tab: enables you to start, stop, forward, and reverse the playback and select positions in waveform file restore mode.
 - File operation tab: enables you to save and restore .csv waveform files and save images.
- Communication control area: enables you to start and stop oscilloscope communication, save channel parameters, set trigger modes, and access help.
- Information display area: enables you to view the names of content that is being monitored through a channel, and control the display and hiding of measurement results.

9**Fault handling**

9.1 Servo drive faults and workarounds.....	268
9.2 CANopen communication faults and workarounds.....	279

9.1 Servo drive faults and workarounds

Code	Name	Possible cause	Workaround
Er01-0	IGBT fault	<p>The drive actual output current exceeds the specified value.</p> <ol style="list-style-type: none"> 1. Drive fault (such as drive circuit or IGBT fault). 2. Drive cables U, V, and W are short connected, or drive cables are grounded or contacted improperly. 3. The motor breaks down. 4. Drive cables U, V, and W are connected in reverse phases. 5. Improper parameter settings cause system divergence. 6. The ACC/DEC time in the start or stop process is too short. 7. Instantaneous load is too heavy. 	<ol style="list-style-type: none"> 1. Remove the motor cables and then enable the drive. If the fault persists, replace the drive. 2. Ensure the motor cables and wiring are in good conditions. 3. Reduce the settings of P0.10 and P0.11 to reduce the maximum output torque. 4. Increase the ACC/DEC time. 5. Replace the drive with a new one with greater power. 6. Replace the motor.
Er01-5	IPM fault	<p>The drive actual output current exceeds the specified value.</p> <ol style="list-style-type: none"> 1. Drive fault (such as drive circuit or IGBT fault). 2. Drive cables U, V, and W are short connected, or drive cables are grounded or contacted improperly. 3. The motor breaks down. 4. Drive cables U, V, and W are connected in reverse phases. 5. Improper parameter 	<ol style="list-style-type: none"> 1. Remove the motor cables and then enable the drive. If the fault persists, replace the drive. 2. Ensure the motor cables and wiring are in good conditions. 3. Reduce the settings of P0.10 and P0.11 to reduce the maximum output torque. 4. Increase the ACC/DEC time. 5. Replace the drive with a new one with greater power. 6. Replace the motor.

Code	Name	Possible cause	Workaround
		settings cause system divergence. 6. The ACC/DEC time in the start or stop process is too short. 7. Instantaneous load is too heavy.	
Er02-0	Encoder fault–Encoder communication exception	1. The encoder is not connected.	1. Connect the encoder according to the correct wiring method.
Er02-1	Encoder fault–Encoder feedback deviation too large	2. The encoder plug contact is loose.	2. Ensure the encoder plug contact is proper.
Er02-2	Encoder fault– Parity error	3. One of encoder signal cables U, V, W, A, B, and Z is disconnected.	3. Replace the encoder cable.
Er02-3	Encoder fault–CRC error	4. Encoder phases A and B are reverse.	4. Ensure the encoder power voltage is proper.
Er02-4	Encoder fault–Frame error	5. Noise causes communication interruption or data exceptions.	5. Eliminate the conditions that disturb encoder cables. Route encoder cables and motor cables separately.
Er02-5	Encoder fault–Short frame error	6. Encoder communicates properly but with data exceptions.	6. Connect the shielded cables for the encoder to the FG.
Er02-6	Encoder fault–Encoder exception reporting	7. The FPGA that communicates with the encoder reports timeout.	7. If an encoder disconnection fault is reported during power-on, check the setting of P0.01 and then ensure the encoder type supported by the drive is the same as the actual encoder type.
Er02-7	Encoder fault–Second-encoder timeout	8. The drive does not support the encoder type.	
Er02-8	Encoder fault–Encoder battery low-voltage alarm	When the multiturn absolute encoder is used, the external battery voltage of the encoder is between 3.0V–3.2V.	1. Ensure the encoder battery cable is connected properly. 2. Use the multimeter to check whether the external battery voltage is less than 3.2V. If yes, replace the battery. 3. Replace the battery when the drive power is on. Otherwise, encoder data may be lost.

Code	Name	Possible cause	Workaround
Er02-9	Encoder fault–Encoder battery undervoltage	When the multiturn absolute encoder is used, the external battery voltage of the encoder is between 2.5V–3.0V.	<ol style="list-style-type: none"> 1. Ensure the encoder battery cable is connected properly. 2. Use the multimeter to check whether the external battery voltage is less than 3.0V. If yes, replace the battery. 3. Replace the battery when the drive power is on. Otherwise, encoder data may be lost.
Er02-a	Encoder fault–Encoder overheating	The encoder feedback temperature is higher than the temperature threshold for protection against overheating.	<ol style="list-style-type: none"> 1. Ensure the temperature threshold for protection against overheating is correct. 2. Stop the motor to decrease the encoder temperature.
Er02-b	Encoder fault–Encoder EEPROM writing error	If the motor is used with a communication encoder, a communication transmission or data check error occurs when the drive updates data to the encoder EEPROM.	<ol style="list-style-type: none"> 1. Ensure encoder cables are connected properly and eliminate the conditions that disturbs encoder communication. 2. Make multiple writing tries. If the fault is reported repeatedly, replace the motor.
Er02-c	Encoder fault–No data in encoder EEPROM	If the motor is used with a communication encoder, no data is found in the encoder EEPROM when the motor attempts to read data from it during power-on.	<ol style="list-style-type: none"> 1. Select the motor model based on the setting of P0.00 and execute the operation of writing data to the encoder EEPROM through P4.97. 2. Mask this fault through P4.98. <p>The motor parameters in the drive EEPROM are used for initialization.</p>
Er02-d	Encoder fault–Encoder EEPROM data check error	If the motor is used with a communication encoder, a data check error occurs when the motor attempts to read data from the encoder EEPROM during power-on.	<ol style="list-style-type: none"> 1. Ensure encoder cables are connected properly and eliminate the conditions that disturbs encoder communication. 2. Select the motor model based on the setting of P0.00 and execute the operation of writing

Code	Name	Possible cause	Workaround
			data to the encoder EEPROM through P4.97 so that data in the encoder EEPROM is updated. 3. Mask the this fault through P4.98. The motor parameters in the drive EEPROM are used for initialization.
Er03-0	Current sensor fault–Phase-U current sensor fault	1. The current sensor or detection circuit is abnormal. 2. The motor shaft is powered on in non-static state.	Repower on the motor shaft in static state. If the fault is reported repeatedly, replace the drive.
Er03-1	Current sensor fault–Phase-V current sensor fault		
Er03-2	Current sensor fault–Phase-W current sensor fault		
Er04-0	System initialization fault	There are failed self-check items after power-on initialization is complete.	1. Perform repower-on. 2. If the fault occurs repeatedly, replace the drive.
Er05-1	Setting fault–Motor model not exist	P0.00 is set incorrectly.	1. Ensure the motor model is set correctly. 2. Ensure the motor parameter model matches the drive power class.
Er05-2	Setting fault–Motor and drive model not match		
Er05-3	Setting fault–Incorrect software limits	Software limits are set incorrectly. The setting of P0.35 is equal to or less than that of P0.36.	Set P0.35 and P0.36 correctly.
Er05-4	Setting fault–Incorrect homing mode	The setting of P5.10 is incorrect.	Set P5.10 correctly.
Er05-5	Setting fault–PTP-control travel overflow	The single increment of a PTP idle travel exceeds ($2^{31}-1$).	Ensure a single travel is not greater than ($2^{31}-1$) in absolute position mode.
Er07-0	Regenerative brake over-discharge	1. The brake resistor power is low. 2. The motor speed is too high or the deceleration is	1. Replace the internal brake resistor with an external one and increase the power. 2. Modify the deceleration time

Code	Name	Possible cause	Workaround
		too quick, which causes the failure to absorb the regenerate energy within specified time. 3. The action limit of the external brake resistor is restricted to the duty ratio 10%.	and reduce the regenerative discharge action rate. 3. Reduce the motor speed. 4. Improve the capacity of the motor and drive.
Er08-0	AI overvoltage fault–AI 1	The voltage input to the port of analog input 1 exceeds the setting of P3.22.	1. Set P3.22, P3.25, and P3.75 correctly. 2. Ensure the terminal wiring is
Er08-1	AI overvoltage fault–AI 2	The voltage input to the port of analog input 2 exceeds the setting of P3.25.	proper. 3. Set P3.22, P3.25, and P3.75 to 0 to disable protection.
Er09-0	EEPROM fault– Read/write error	1. Data is damaged in the data storage area when the drive reads data from the EEPROM. 2. Writing data to the EEPROM is disturbed.	1. Try again after repower-on. 2. If the fault occurs repeatedly, replace the drive.
Er09-1	EEPROM fault–Data check error	1. The data read from EEPROM during power-on is different from the data that is written. 2. The driver DSP version is updated.	1. Set all parameters again. 2. If the fault occurs repeatedly, replace the drive.
Er10-0	Hardware fault–FPGA fault	The FPGA on the control board reports a fault.	1. Repower on the control board. 2. If the fault occurs repeatedly, replace the drive.
Er10-1	Hardware fault– Communication card fault	The external communication card is faulty.	1. Perform repower-on. 2. If the fault occurs repeatedly, replace the communication card.
Er10-2	Hardware fault–Ground short-connection fault	One of the motor cables V and W is short connected to the ground, which is found in ground short-connection detection during drive power-on.	1. Ensure motor cables are connected properly. 2. Replace motor cables

Code	Name	Possible cause	Workaround
Er10-3	Hardware fault–External input fault	This fault occurs when the digital terminal configured with the external fault input function acts.	<ol style="list-style-type: none"> 1. Clear the external fault input. 2. Repower on the drive.
Er10-4	Hardware fault–Emergency stop fault	This fault occurs when the digital terminal configured with the emergency stop function acts.	<ol style="list-style-type: none"> 1. Clear the emergency stop input. 2. Repower on the drive.
Er10-5	Hardware fault–RS485 communication fault	Strong EMI on RS485 communication circuit causes a drive serial communication alarm.	<ol style="list-style-type: none"> 1. Use shielded twisted pairs for RS485 communication. 2. Route communication cables and motor cables separately.
Er10-6	Hardware fault–AC power phase loss	One of the phases R, S, and T is lost.	<ol style="list-style-type: none"> 1. Ensure power wiring is proper. 2. Set P0.12 correctly.
Er11-0	Software fault–Motor control task re-entry	<ol style="list-style-type: none"> 1. The DSP CPU utilization is too high. 2. The DSP has bugs. 	<ol style="list-style-type: none"> 1. Disable unnecessary functions. 2. Contact the customer service personnel to update the DSP.
Er11-1	Software fault–Periodic task re-entry		
Er11-2	Software fault–Illegal operation		
Er12-0	I/O fault–Duplicate digital input assignment	Two or more digital inputs are configured with the same function.	Set P3.00–P3.07 and ensure each setting is unique.
Er12-2	I/O fault–Pulse input frequency too high	<p>The pulse input frequency detected by the drive is higher than the specified frequency.</p> <ol style="list-style-type: none"> 1. External input pulse signal frequency is too high. 2. There is damage to the internal pulse frequency detection circuit of the drive. 	<ol style="list-style-type: none"> 1. Reduce the external input pulse signal frequency. 2. If the fault persists though the external input signal is normal, replace the drive.
Er13-0	Main circuit overvoltage	<p>The DC voltage of the drive main circuit is higher than the specified voltage.</p> <ol style="list-style-type: none"> 1. The grid voltage is too high. 	<ol style="list-style-type: none"> 1. Ensure the grid input voltage is within the allowed range. 2. Ensure the internal brake resistor is not loose or damaged. Ensure the external brake resistor

Code	Name	Possible cause	Workaround
		2. No brake resistor or pipe is connected during braking or the brake resistor is damaged. 3. The DEC time in the stop process is too short. 4. The internal DC voltage detection circuit of the drive is damaged.	is not damaged. 3. Increase the DEC time. 4. Check R0.07 when the drive is disabled. If it is abnormal and does not match the grid input voltage, replace the drive.
Er13-1	Main circuit undervoltage	The DC voltage of the drive main circuit is higher than the specified voltage. 1. The grid voltage is too low. 2. The buffer relay is not closed. 3. The drive output power is too high. 4. The internal DC voltage detection circuit of the drive is damaged.	1. Ensure the grid input voltage is within the allowed range. 2. Repower on the drive. Ensure the buffer relay is closed. If the buffer relay is closed, there is a sound indicating actuation. 3. Check R0.07 when the drive is disabled. If it is abnormal and does not match the grid input voltage, replace the drive.
Er14-0	Control power undervoltage fault	The detected control power DC voltage of the drive is lower than the specified value. The grid voltage is too low.	Check whether grid input voltage is lower than the allowed value.
Er17-0	Drive overload	The short-time load on the drive is too heavy. The IGBT wafer is in overtemperature state.	1. The load is too heavy, which exceeds the drive capacity. Therefore, this causes the IGBT wafer overtemperature. 2. If this fault occurs, you cannot frequently power off and power on, and you need to ensure the restart interval is greater than two minutes since the internal of the wafer needs to be sufficiently cooled.

Code	Name	Possible cause	Workaround
Er17-1	Drive overload 2	The short-time load on the drive is too heavy.	<ol style="list-style-type: none"> 1. Reduce the load. 2. Ensure there is no phase dislocation or phase loss to the UVW wiring of the motor and the encoder is correct. 3. Ensure the motor matches the drive.
Er18-0	Motor overload	<ol style="list-style-type: none"> 1. Long-time over-rated torque operation. 2. Short-time maximum torque operation, overload, collision, jamming, or electromagnetic brake not released (fault characteristics: the output current is the maximum value, and the output voltage is much less than the power supply voltage.) 3. Incorrect cable phase sequence, loose power line, cable damage or open circuit (fault characteristics: the output current is zero, and the output voltage is close to the power supply voltage.) 4. The motor encounters phase loss or three-phase unbalance. 5. The gain parameter settings are improper, or the system vibrates, which mostly occurs in the flexible transmission industry. 6. For a multi-shaft system, the encoder and power line are cross connected to 	<ol style="list-style-type: none"> 1. The model selection is incorrect. Re-select the drive or motor. 2. The short-time load is too heavy. Check whether the load is too heavy, whether stalling occurs, whether the electromagnetic brake is opened, and other factors. 3. Check whether the motor has incorrect UVW wiring or phase loss, whether the plug is inserted tightly, and whether the power terminal and the aviation plug are secured tightly. 4. If the motor encounters three-phase imbalance, replace the servo motor. 5. Reduce the gain. 6. Check whether multi-shaft cables cross and correct it the if any. 7. Replace the servo drive.

Code	Name	Possible cause	Workaround
		different axes. 7. Drive hardware is damaged.	
Er18-1	Motor overtemperature	The motor temperature is higher than the temperature threshold for protection against overheating.	Replace the motor with greater power.
Er19-0	Speed fault–Overspeed	The motor speed absolute value exceeds the setting of P4.32. 1. The motor stalls or motor phases U, V, and W are in reverse sequence. 2. The electronic gear ratio or motor speed loop control parameters are set improperly. 3. The setting of P4.32 is less than that of P4.31. 4. The encoder feedback signal is interfered.	1. Ensure the electronic gear ratio is set properly. 2. Ensure the motor speed loop control parameters are set properly. 3. Ensure the motor cable phases are in correct sequence. 4. Ensure the motor and encoder are connected properly. 5. Replace the motor with a new one with a higher speed.
Er19-1	Speed fault–CCW overspeed	The speed feedback exceeds the setting of P4.40 by more than 20ms.	1. Ensure the encoder is normal. 2. Set P4.40 properly.
Er19-2	Speed fault–CW overspeed	The speed feedback exceeds the setting of P4.41 by more than 20ms.	1. Ensure the encoder is normal. 2. Set P4.41 properly.
Er19-3	Speed fault–Overspeed parameter set incorrectly	The setting of P4.40 is less than 0 or that of P4.41 is greater than 0.	1. Ensure the encoder is connected properly. 2. P4.40 or P4.41 is set incorrectly.
Er19-4	Overspeed fault–Motor runaway	The motor power cable connection is incorrect or the motor code setting is incorrect.	1. Check whether the encoder is connected reliably. 2. Check whether the power cable phase sequence is correct. 3. Check whether the motor code setting is correct. 4. Set P4.35 correctly.

Code	Name	Possible cause	Workaround
Er20-0	Speed deviation fault	<p>In non-torque mode, the deviation between the motor speed and speed command exceeds the setting of P4.39.</p> <ol style="list-style-type: none"> The motor phases U, V, and W are in reverse sequence or motor cables are not connected. The motor load is too heavy, which causes motor stalling. The drive force is insufficient, which causes the motor stalling. The speed loop control parameters are set improperly. The setting of P4.39 is too low. 	<ol style="list-style-type: none"> Ensure the motor cable phases are in correct sequence and motor cables are connected properly. Check whether the conveyer belt or chain is too tight or the workbench reaches the boundary or encounters obstacles. If yes, resolve the problem. Ensure the speed loop control parameters are set properly, the drive is not damaged, and the servo system model is correct. Increase the setting of P4.39. Set P4.39 to 0, which disables the detecting for a speed deviation fault.
Er21-0	Position overtravel–CCW	<p>In position mode, the CCW limit switch is touched or the accumulated feedback pulse exceeds the setting of P0.35.</p>	<ol style="list-style-type: none"> Ensure the CCW limit switch signal is correct. Ensure the setting of P0.35 is proper.
Er21-1	Position overtravel–CW	<p>In position mode, the CW limit switch is touched or the accumulated feedback pulse exceeds the setting of P0.36.</p>	<ol style="list-style-type: none"> Ensure the CW limit switch signal is correct. Ensure the setting of P0.36 is proper.
Er22-0	Position deviation fault	<ol style="list-style-type: none"> Server response time is too slow. Therefore the residual pulses exceed the setting of P4.33. The motor load is too heavy, which causes motor stalling. Pulse input frequency is too high, exceeding the maximum motor speed. 	<ol style="list-style-type: none"> Check whether the conveyer belt or chain is too tight or the workbench reaches the boundary or encounters obstacles. If yes, resolve the problem. Increase the settings of position loop or speed feed-forward gain parameters. Alternatively, increase the setting of P4.33.

Code	Name	Possible cause	Workaround
		4. The step variable in the position command input exceeds the setting of P4.33.	3. Adjust electronic gear ratio parameters. 4. Reduce the step variable in the position command input.
Er22-1	Hybrid control deviation too large	In fully-closed loop control, the feedback position deviation between the grating ruler and encoder exceeds the setting of P4.64.	1. Ensure the motor and load are connected properly. 2. Ensure the grating ruler and encoder are connected properly. 3. Ensure P4.60, P4.61, and P4.62 are set properly.
Er22-2	Position increment overflow	The single-variation position command after electronic gear ratio conversion exceeds $(2^{31}-1)$.	1. Decrease the single variation of the position command. 2. Modify the electronic gear ratio to a proper setting.
Er23-0	Drive overtemperature	1. The ambient temperature of the drive exceeds the specified temperature. 2. The drive is overloaded.	1. Reduce the ambient temperature and improve the ventilation condition. 2. Replace it with a servo system with greater power. 3. Increase the ACC/DEC time and reduce the load.
Er25-4	Application fault–Encoder offset angle test timeout	An exception occurred in the encoder offset angle test.	Ensure the motor shaft can rotate freely and then carry out the test after repower-on.
Er25-5	Application fault–Encoder offset angle test failed	There is great fluctuation in current feedback in the encoder offset angle test.	Reduce the setting of P4.53 and then carry out the test after repower-on.
Er25-6	Application fault–Homing offside	The limit switch or software limit is enabled during homing.	Modify the setting of P5.10 and then execute homing after repower-on.
Er25-7	Application fault–Inertia identifying failed	1. During inertia identifying, the motor stops rotating with vibration of longer than 3.5s. 2. The actual ACC time for inertia identifying is too short. 3. The inertia identifying speed is lower than 150r/min.	1. Improve the mechanical rigidity properly. 2. Increase the setting of P1.07. 3. Increase the setting of P1.06.

Code	Name	Possible cause	Workaround
Er25-8	Application fault– Magnetic pole check failed	1. The power cable phase sequence is incorrect. 2. The encoder direction conflicts with the power cable phase sequence. 3. External force or overload occurs in the check.	1. Ensure power cable connection is correct. 2. Ensure encoder settings are correct. 3. Eliminate the condition that causes the external force.
Er25-9	Application fault– Overtravel/overspeed in confirmation of magnetic pole check	The motor motion range is too large or speed is too fast in the confirmation of magnetic pole.	Increase the setting of P6.70.
Er25-a	Application fault– Out-of-range in magnetic pole check	The motor motion range exceeds the specified range in the magnetic pole check.	Increase the settings of P6.60 and P6.61.

9.2 CANopen communication faults and workarounds

Code	Name	Possible cause	Workaround
Er22-3	Synchronization signal timeout	In Interpolation position mode, the time interval between two adjacent synchronization frame signals is more than twice the communication cycle.	1. Check communication cables to improve communication reliability. 2. Ensure the synchronization frame generation interval of the signal generation source is correct.
Er22-4	Full position command buffer	CANopen PTP position command buffer is full.	Increase the time interval for sending PTP control position commands.
Er26-0	CANopen offline	The master node does not receive heartbeat packets from a slave node within a period of time.	Check communication connection.
Er26-1	SDO index not exist	When the SDO reads or writes parameters, the index does not exist in the object dictionary or is not supported by the servo drive.	Check the index on the master node and on the servo drive. Modify the index in the EDS file.
Er26-2	SDO sub-index not exist	When the SDO reads or writes parameters, the index	Check the index and sub-index on the master node and on the servo

Code	Name	Possible cause	Workaround
		exists in the object dictionary, but the sub-index does not exist in the dictionary or is not supported by the servo drive.	drive. Modify the index and sub-index in the EDS file.
Er26-3	Incorrect SDO data length	The length information in SDO read or write commands does not match the data length in the servo drive object dictionary.	Adjust the length in SDO read or write commands according to the data length in the servo drive object dictionary.
Er26-4	SDO data out of range	The data that the SDO writes exceeds the data range in the servo drive object dictionary.	Adjust the size of data written by the SDO according to the data range in the object dictionary.
Er26-5	Modification not allowed for read-only	There are attempts to modify read-only parameters.	Eliminate the condition for making the attempts to modify read-only parameters.
Er26-6	Incorrect PDO mapping length	The total length of data mapped from the PDO exceeds 64 bits.	Correct the length settings.
Er26-7	PDO mapping data not exist	The parameters associated with the data mapped from the PDO are not found in the object dictionary.	Ensure the PDO mapping index and sub-index exist in the object dictionary.
Er26-8	PDO modification not allowed in operational state	There are attempts to modify PDO mappings.	Switch the CANopen status machine to pre-operational and then modify PDO mappings.
Er26-9	PDO mapping not allowed	There are attempts to map parameters that disallow mapping to the PDO.	Ensure there are no read-only PDO parameters that are mapped to the RPDO.
Er26-a	Synchronization signal too fast	In synchronization working mode, the number of frames received by a slave node exceeds the range supported by the baud rate.	<ol style="list-style-type: none"> 1. Modify the time interval for the master node to send data or synchronization frames. 2. Change the baud rate.
Er26-b	Receiving fault	CAN communication is offline or the error receiving counter exceeds 128.	<ol style="list-style-type: none"> 1. Check communication connection. 2. Restart the servo drive.

Code	Name	Possible cause	Workaround
Er26-c	Sending fault	CAN communication is offline or the error receiving counter exceeds 128.	<ol style="list-style-type: none"> 1. Check communication connection. 2. Restart the servo drive.
Er26-d	Duplicate synchronization signal	In the case where a slave node is configured to generate synchronization signals, external synchronization signals are received.	Modify configuration so that there is only one synchronization signal generation source in the entire communication network.
Er26-e	Bus load ratio too high	In asynchronous working mode, the number of frames received by a slave node exceeds the range supported by the baud rate.	<ol style="list-style-type: none"> 1. Modify the time interval for the master node to send data frames. 2. Modify the mode for the slave node to send TPDOs. 3. Change the baud rate.
Er26-f	Incorrect parameter modification status	The SDO attempts to modify parameters in a state that disallows modification.	Adjust the CANopen status machine to the Pre-OP or OP state and then try to modify parameters.

10

Appendix

10.1 Parameters about settings283
10.2 Parameters about monitoring310
10.3 Common monitoring parameters314
10.4 Fault codes315
10.5 Parameter setting history319

10.1 Parameters about settings

Note:

In the **Applicable mode** column, P indicates position mode, S indicates speed mode, and T indicates torque mode.

For function codes:

- Marked with the superscript "1", the parameter settings take effect only after the drive is restarted or repowered on.
- Marked with the superscript "2", the parameter settings take effect only when the servo stops. The modification during running does not take effect.
- Marked with the superscript "**", the parameter settings are not stored after the drive is powered off.

Function code	Parameter	Unit	Setting range	Default	Applicable mode
P0 Basic control					
P0.00 ¹	Motor model	-	0-9999999	1010104	PST
P0.01 ¹	Encoder type	-	1-12	4	PST
P0.02 ¹	Forward direction of motor rotating	-	0-1	0	PST
P0.03 ¹	Control mode	-	0-9	0	PST
P0.04*	Internal enabling command	-	0-1	0	PST
P0.05	Jogging speed	r/min	0-1000	200	PST
P0.06 ¹	Numerator of frequency division output coefficient	-	$0-(2^{31}-1)$	10000	PST
P0.07 ¹	Denominator for frequency division output coefficient	-	$1-(2^{31}-1)$	131072	PST
P0.08 ¹	Reverse frequency division output	-	0-1	0	PST
P0.09	Torque limit mode	-	0-6	1	PS
P0.10	Max. torque limit 1	%	0.0-500.0	300.0	PST
P0.11	Max. torque limit 2	%	0.0-500.0	300.0	PS
P0.12	Input selection for 3PH input-type servo power supply	-	0-1	0	PST
P0.13 ¹	External brake resistor power	W	0-5000	200	PST

Function code	Parameter	Unit	Setting range	Default	Applicable mode
P0.14 ¹	External brake resistor resistance	Ω	1–1000	60	PST
P0.15	Default monitored parameters	-	0–22	0	PST
P0.16	Parameter modification lock	-	0–1	0	PST
P0.17	Mode for writing to EEPROM	-	0–1	0	PST
P0.18*	Factory password	-	0–65535	0	PST
P0.19	Main circuit power input type	-	0–1	0	PST
P0.20 ¹	Position command source	-	0–4	0	P
P0.22 ¹	Pulses per motor resolution	reference unit	0–(2 ³¹ -1)	10000	P
P0.23 ¹	Pulse input mode	-	0–2	0	P
P0.24 ¹	Reverse pulse input direction	-	0–1	0	P
P0.25	Numerator of electronic gear ratio 1	-	0–(2 ³¹ -1)	0	P
P0.26 ²	Denominator of electronic gear ratio	-	1–(2 ³¹ -1)	10000	P
P0.27	Numerator of electronic gear ratio 2	-	0–(2 ³¹ -1)	0	P
P0.28	Numerator of electronic gear ratio 3	-	0–(2 ³¹ -1)	0	P
P0.29	Numerator of electronic gear ratio 4	-	0–(2 ³¹ -1)	0	P
P0.33 ²	Position command smooth filter time	ms	0.0–1000.0	0.0	P
P0.34 ²	Position command FIR filter time	ms	0.0–1000.0	0.0	P
P0.35	Software limit in CCW position control	reference unit	-(2 ³¹ -1)–(2 ³¹ -1)	0	P
P0.36	Software limit in CW position control	reference unit	-(2 ³¹ -1)–(2 ³¹ -1)	0	P

Function code	Parameter	Unit	Setting range	Default	Applicable mode
P0.37	Position command mode	-	0-1	0	P
P0.38	Enabling fully-closed loop	-	0-2	0	P
P0.40	Speed command source	-	0-5	1	S
P0.41	Speed command direction setting	-	0-1	0	S
P0.42	Gain of AI 1	[P3.26 unit]/V	10-2000	100	PST
P0.43	Reverse of AI 1	-	0-1	0	PST
P0.45	Dead zone of AI 1	V	0.000-3.000	0.000	PST
P0.46	Internal speed 1/speed limit 1	r/min	-20000-20000	100	ST
P0.47	Internal speed 2/speed limit 2	r/min	-20000-20000	0	ST
P0.48	Internal speed 3/speed limit 3	r/min	-20000-20000	0	ST
P0.49	Internal speed 4/speed limit 4	r/min	-20000-20000	0	ST
P0.50	Internal speed 5	r/min	-20000-20000	0	S
P0.51	Internal speed 6	r/min	-20000-20000	0	S
P0.52	Internal speed 7	r/min	-20000-20000	0	S
P0.53	Internal speed 8	r/min	-20000-20000	0	S
P0.54	ACC time	ms	0-30000	0	S
P0.55	DEC time	ms	0-30000	0	S
P0.56	S-curve ACC time	ms	0-1000	0	S
P0.57	S-curve DEC time	ms	0-1000	0	S
P0.58	Zero speed clamp mode	-	0-3	0	ST
P0.59	Zero speed clamp speed threshold	r/min	10-20000	30	S
P0.60	Torque command source	-	0-3	1	T
P0.61	Torque command direction setting	-	0-1	0	T
P0.62	Gain of AI 2	[P3.27 unit]/V	0-2000	100	PST
P0.63	Reverse of AI 2	-	0-1	0	PST
P0.65	Dead zone of AI 2	V	0.000-3.000	0.000	PST
P0.66	Internal torque command	%	-500.0-500.0	0.0	T
P0.67	Speed limit mode	-	0-1	0	T

Function code	Parameter	Unit	Setting range	Default	Applicable mode
P0.68	Torque command ramp time	ms	0–10000	0	T
P0.69	DEC time for quick stop	ms	0–10000	500	PST
P0.70 ¹	Absolute encoder work mode	-	0–1	0	PST
P0.71*	Clear absolute encoder multiturn	-	0–1	0	PST
P0.90	Max. speed limit of control mode switching	r/min	0–1000	100	PST
P0.91	Positioning reference of control mode switching	reference unit	$-1-(2^{31}-1)$	-1	PST
P0.92	Position mode exiting method	-	0–1	0	PST
P0.93	Exit mode of speed mode switching	-	0 - 1	1	PST
P0.99	FIR filter level of speed detection	-	1–31	1	PST
P1 Autotuning control					
P1.00	Tune inertia online	-	0–1	0	PST
P1.01	Inertia ratio 1	%	0–10000	250	PST
P1.02	Inertia ratio 2	%	0–10000	250	PST
P1.03	Mechanical rigidity	-	0–31	13	PST
P1.04*	Tune inertia offline	-	0–1	0	PST
P1.05	Inertia identifying mode	-	0–3	0	PST
P1.06	Max. rotations by inertia identifying	r	0.2–20.0	2.0	PST
P1.07	ACC time for inertia identifying	ms	2–1000	200	PST
P1.08	Inertia identifying class	-	0–3	1	PST
P1.19	Resonance detection sensitivity	%	0.2–100.0	5.0	PST
P1.20	Resonance detection mode	-	0–7	0	PST
P1.21*	Mechanical resonant frequency 1	Hz	0–5000	5000	PST

Function code	Parameter	Unit	Setting range	Default	Applicable mode
P1.22*	Mechanical resonant frequency 2	Hz	0–5000	5000	PST
P1.23	Frequency of notch filter 1	Hz	50–5000	5000	PST
P1.24	Q factor of notch filter 1	-	0.50–16.00	1.00	PST
P1.25	Depth of notch filter 1	%	0–100	0	PST
P1.26	Frequency of notch filter 2	Hz	50–5000	5000	PST
P1.27	Q factor of notch filter 2	-	0.50–16.00	1.00	PST
P1.28	Depth of notch filter 2	%	0–100	0	PST
P1.29	Frequency of notch filter 3	Hz	50–5000	5000	PST
P1.30	Q factor of notch filter 3	-	0.50–16.00	1.00	PST
P1.31	Depth of notch filter 3	%	0–100	0	PST
P1.32	Frequency of notch filter 4	Hz	50–5000	5000	PST
P1.33	Q factor of notch filter 4	-	0.50–16.00	1.00	PST
P1.34	Depth of notch filter 4	%	0–100	0	PST
P1.35	Vibration control mode in position command	-	0–2	0	P
P1.36	Vibration control frequency 1	Hz	0.0–200.0	0.0	P
P1.37	Coefficient of vibration control filter 1	-	0.00–1.00	1.00	P
P1.38	Vibration control frequency 2	Hz	0.0–200.0	0.0	P
P1.39	Coefficient of vibration control filter 2	-	0.00–1.00	1.00	P
P2 Motor control					
P2.00	Speed gain 1	Hz	0.0–3276.7	27.0	PST
P2.01	Speed integral time constant 1	ms	0.1–1000.0	21.0	PST
P2.02	Position gain 1	1/s	0.0–3276.7	48.0	P
P2.03	Speed detection filter 1	Hz	100–5000	5000	PST
P2.04	Torque filter 1	ms	0.00–25.00	0.84	PST
P2.05	Speed gain 2	Hz	0.0–3276.7	27.0	PST
P2.06	Speed integral time constant 2	ms	0.1–1000.0	1000.0	PST
P2.07	Position gain 2	1/s	0.0–3276.7	57.0	P

Function code	Parameter	Unit	Setting range	Default	Applicable mode
P2.08	Speed detection filter 2	Hz	100–5000	5000	PST
P2.09	Torque filter 2	ms	0.00–25.00	0.84	PST
P2.10	Speed feed-forward gain	%	0.0–100.0	0.0	P
P2.11	Speed feed-forward filter time	ms	0.00–64.00	0.50	P
P2.12	Torque feed-forward gain	%	0.0–100.0	0.0	PS
P2.13	Torque feed-forward filter time	ms	0.00–64.00	0.00	PS
P2.14	IPPI coefficient 1	%	0–1000	100	PST
P2.15	IPPI coefficient 2	%	0–1000	100	PST
P2.20	Setting of gain 2	-	0–1	1	PST
P2.22	Switching trigger in position control	-	0–9	0	P
P2.23	Switching delay in position control	ms	0–10000	0	P
P2.24	Switching level in position control	-	0–20000	0	P
P2.25	Switching lag in position control	-	0–20000	0	P
P2.26	Position gain switching time	ms	0–10000	0	P
P2.27	Switching trigger in speed control	-	0–5	0	S
P2.28	Switching delay in speed control	ms	0–10000	0	S
P2.29	Switching level in speed control	-	0–20000	0	S
P2.30	Switching lag in speed control	-	0–20000	0	S
P2.31	Switching trigger in torque control	-	0–3	0	T
P2.32	Switching delay in torque control	ms	0–10000	0	T
P2.33	Switching level in torque control	-	0–20000	0	T

Function code	Parameter	Unit	Setting range	Default	Applicable mode
P2.34	Switching lag in torque control	-	0–20000	0	T
P2.41 ²	Disturbance observer	-	0–2	0	PST
P2.42	Disturbance observer compensation gain	%	0–100	0	PS
P2.43	Disturbance observer cut-off frequency	Hz	0–3000	200	PS
P2.44	Torque command offset	%	-500.0–500.0	0.0	PST
P2.50 ²	Fully-closed loop vibration suppressor	-	0–2	0	PS
P2.51	Fully-closed loop vibration suppressor cut-off frequency	Hz	1.0–500.0	100.0	PS
P2.52	Fully-closed loop vibration suppressor compensation gain	%	0–1000	0	PS
P2.53	Medium frequency vibration control switch	-	0–1	0	PST
P2.54	Vibration control frequency	Hz	1–2000	100	PST
P2.55	Inertia adjustment	%	1–1000	100	PST
P2.56	Attenuation gain	%	0–1000	0	PST
P2.57	Adjustment on filter time 1	0.01ms	-10–10	0	PST
P2.58	Adjustment on filter time 2	0.01ms	-10–10	0	PST
P2.60 ²	Speed observer	-	0–2	0	PST
P2.61	Speed observer gain	Hz	1–1000	100	PST
P2.70	Friction compensation cut-off speed	r/min	0–1000	20	PST
P2.71	CCW torque coefficient of friction compensation	%/(10r/min)	0.0–100.0	0.0	PST
P2.72	CW torque coefficient of friction compensation	%/(10r/min)	-100.0–0.0	0.0	PST
P2.73	Friction compensation	-	0–1	0	PST
P2.85	Torque feed-forward	-	0–1	0	PS
P2.91	No-deviation control gain	1/s	1.0–2000.0	50.0	P

Function code	Parameter	Unit	Setting range	Default	Applicable mode
P2.92	No-deviation control attenuation coefficient	%	50.0–200.0	100.0	P
P3 I/O management					
P3.00 ¹	Input of digital 1	-	0x000–0x136	0x003	PST
P3.01 ¹	Input of digital 2	-	0x000–0x136	0x00D	PST
P3.02 ¹	Input of digital 3	-	0x000–0x136	0x004	PST
P3.03 ¹	Input of digital 4	-	0x000–0x136	0x016	PST
P3.04 ¹	Input of digital 5	-	0x000–0x136	0x019	PST
P3.05 ¹	Input of digital 6	-	0x000–0x136	0x01A	PST
P3.06 ¹	Input of digital 7	-	0x000–0x136	0x001	PST
P3.07 ¹	Input of digital 8	-	0x000–0x136	0x002	PST
P3.08 ¹	Input of digital 9	-	0x000–0x136	0x007	PST
P3.09 ¹	Input of digital 10	-	0x000–0x136	0x008	PST
P3.10 ¹	Output of digital 1	-	0x000–0x11F	0x001	PST
P3.11 ¹	Output of digital 2	-	0x000–0x11F	0x003	PST
P3.12 ¹	Output of digital 3	-	0x000–0x11F	0x007	PST
P3.13 ¹	Output of digital 4	-	0x000–0x11F	0x00D	PST
P3.16	DI-based encoder capturing	-	0–778	0	PST
P3.20	Offset of AI 1	V	-10.000–10.000	0.000	PST
P3.21	Filter of AI 1	ms	0.0–1000.0	1.0	PST
P3.22	OV protection threshold of AI 1	V	0.000–10.000	0.000	PST
P3.23	Offset of AI 2	V	-10.000–10.000	0.000	PST
P3.24	Filter of AI 2	ms	0.0–1000.0	0.0	PST
P3.25	OV protection threshold of AI 2	V	0.000–10.000	0.000	PST
P3.26 ¹	Function of AI 1	-	0–7	0	PST
P3.27 ¹	Function of AI 2	-	0–7	3	PST
P3.28	Analog speed compensation gain	%	0.0–100.0	0.0	P
P3.29	Analog torque compensation gain	%	0.0–100.0	0.0	PST
P3.30 ¹	Function of AO 1	-	0–19	0	PST
P3.31	Voltage gain of AO 1	[P3.30 unit]/V	1–214748364	1	PST

Function code	Parameter	Unit	Setting range	Default	Applicable mode
P3.32 ¹	Function of AO 2	-	0–19	0	PST
P3.33	Voltage gain of AO 2	[P3.32 unit]/V	1–214748364	1	PST
P3.34	Offset voltage of AO 1	V	-10.000–10.000	0.000	PST
P3.35	Offset voltage of AO 2	V	-10.000–10.000	0.000	PST
P3.36 ¹	AO format	-	0–2	0	PST
P3.40 ¹	Disable travel limit switch	-	0–2	1	PST
P3.41 ¹	Disable emergency stop	-	0–1	1	PST
P3.43 ¹	Digital input filter	0.125ms	1–800	1	PST
P3.44	Disable command pulse inhibition	-	0–1	0	P
P3.45 ¹	Residual pulse clearing mode	-	0–1	1	P
P3.50	Position arrival range	reference unit	0–2 ¹⁸	100	P
P3.51	Output mode of position arrival	-	0–4	0	P
P3.52	Hold time of position arrival output terminal	ms	0–30000	0	P
P3.53	Speed consistency threshold	r/min	10–20000	50	PST
P3.54	Speed reaching range	r/min	10–20000	1000	PST
P3.55	Zero speed range	r/min	10–20000	50	PST
P3.56	Servo lock time after braking	ms	0–1000	50	PST
P3.57	Electromagnetic brake closing delay	ms	0–30000	500	PST
P3.58 ¹	Motor speed threshold at brake release	r/min	0–1000	30	PST
P3.59	Torque reaching range	%	5.0–300.0	50.0	T
P3.77	AI dead zone mode	-	0–1	0	PST
P3.90	Pulse input filter time	-	0–7	2	PST
P3.92	Pulse feedback filter time	-	0–7	2	PST
P4 Extension and application					
P4.00 ¹	EtherCAT address	-	-1–65535	-1	PST
P4.01 ¹	Local RS485 address	-	1–255	1	PST
P4.02 ¹	CAN baud rate	-	0–5	1	PST
P4.03 ¹	RS485 baud rate	-	0–3	1	PST

Function code	Parameter	Unit	Setting range	Default	Applicable mode
P4.04 ¹	RS485 parity check	-	0–5	0	PST
P4.05 ¹	CAN node no.	-	1–127	1	PST
P4.06	RS485 fault clearing mode	-	0–1	1	PST
P4.07 ¹	EtherCAT synchronization interval	-	0–3	2	PST
P4.08 ¹	EtherCAT synchronization type	-	0–2	0	PST
P4.09 ¹	EtherCAT fault detection time	ms	0–1000	100	PST
P4.10 ¹	Upper computer type	-	0–1	0	PST
P4.11*	Enable bus servo	-	0–1	0	PST
P4.12*	Bus position command	reference unit	$-(2^{31}-1)-(2^{31}-1)$	0	P
P4.13*	Bus speed command	r/min	-20000–20000	0	S
P4.14*	Bus torque command	%	-500.0–500.0	0.0	T
P4.15*	Control mode switching command	-	0–1	0	PST
P4.16*	Gain switching command	-	0–1	0	PST
P4.17*	Electronic gear ratio switching command	-	0–3	0	P
P4.18*	Inertia ratio switching command	-	0–1	0	PST
P4.19*	Zero speed clamp command	-	0–1	0	ST
P4.20*	Clearing residual pulses	-	0–1	0	P
P4.21*	Torque limit switching command	-	0–1	0	PST
P4.22*	External fault reporting command	-	0–1	0	PST
P4.23*	Emergency stop command	-	0–1	0	PST
P4.24*	Vibration control switching command	-	0–1	0	P
P4.30	Stop mode	-	0–3	0	PST
P4.31	Max. motor speed	r/min	0–20000	5000	PST

Function code	Parameter	Unit	Setting range	Default	Applicable mode
P4.32	Overspeed threshold	r/min	0–20000	6000	PST
P4.33	Pulse threshold of position deviation	reference unit	0– 2^{27}	100000	P
P4.34 ¹	Brake OL protection	-	0–2	0	PST
P4.35	Enabling motor runaway detection	-	0–1	0	PST
P4.36 ¹	Main-power UV protection	-	0–1	1	PST
P4.37	Main-power UV detection time	ms	70–2000	70	PST
P4.38	Motor overload rate	%	0.0–500.0	115.0	PST
P4.39	Speed deviation threshold	r/min	0–20000	0	PS
P4.40	Forward speed limit	r/min	0–20000	20000	PST
P4.41	Reverse speed limit	r/min	-20000–0	-20000	PST
P4.42	Internal speed with high resolution	r/min	-20000.0–20000.0	0.0	PST
P4.43	Speed threshold for motor runaway protection	r/min	0–2000.0	30.0	PST
P4.45	OT threshold of medium-power motor	°C	0–200	0	PST
P4.50 ¹	Encoder phase-Z offset	pulse	0–(2^{20} -1)	0	PST
P4.51	Torque limit switching time 1	ms/100%	0–4000	0	PS
P4.52	Torque limit switching time 2	ms/100%	0–4000	0	PS
P4.53	ACR response adjustment	%	10.0–200.0	100.0	PST
P4.54 ¹	Delay after power-on initialization	ms	0–200000	0	PST
P4.60 ¹	Frequency-division numerator of external grating ruler	-	1–(2^{31} -1)	10000	P
P4.61 ¹	Frequency-division denominator of external grating ruler	-	1–(2^{31} -1)	10000	P
P4.62 ¹	Reverse external grating ruler count	-	0–1	0	P

Function code	Parameter	Unit	Setting range	Default	Applicable mode
P4.64 ¹	Hybrid control deviation limit	reference unit	0–2 ²⁷	160000	P
P4.65 ¹	Threshold for hybrid-control deviation clearing	r	0–100	0	P
P4.67 ¹	Signal source of pulse feedback output	-	0–1	0	P
P4.68 ¹	External grating ruler (or encoder 2) resolution	pulse	1–(2 ³¹ -1)	10000	P
P4.69 ¹	Frequency division output source	-	0–4	0	PST
P4.70 ¹	External grating ruler (or encoder 2) phase-Z signal type	-	0–3	0	PST
P4.71 ¹	Type of encoder 2	-	1–12	2	PST
P4.72 ¹	Cascading mode of encoder 2	-	0–4	0	PST
P4.87	CANopen communication cycle	μs	0–(2 ³¹ -1)	0	PST
P4.88	CANopen heartbeat cycle	ms	0–32767	1000	PST
P4.89	Auto stop on CANopen disconnection	-	0–1	0	PST
P4.90*	Fault recovery	-	0–1	0	PST
P4.91*	Parameter saving	-	0–1	0	PST
P4.92*	Factory restore	-	0–1	0	PST
P4.93*	Read fault records	-	0–1	0	PST
P4.94*	Clear fault records	-	0–1	0	PST
P4.95*	Fault record group no.	-	0–9	0	PST
P4.96*	Reserved	-	-	-	PST
P4.97*	Write to encoder EEPROM	-	0–1	0	PST
P4.98*	Mask encoder EEPROM data faults	-	0–1	1	PST
P5 Jogging, homing, and PTP control					
P5.00	Jogging mode	-	0–6	0	P

Function code	Parameter	Unit	Setting range	Default	Applicable mode
P5.01	Jogging increment	reference unit	1–2 ³⁰	50000	P
P5.02	Jogging speed	r/min	1–5000	500	P
P5.03	Jogging ACC/DEC time	ms	2–10000	100	P
P5.04	Jogging wait time	ms	0–10000	100	P
P5.05	Jogging cycles	-	0–10000	1	P
P5.10 ²	Homing mode	-	0–128	0	P
P5.11	Homing upon power-on	-	0–1	0	P
P5.12	High speed at homing step 1	r/min	0–2000	100	P
P5.13	High speed at homing step 2	r/min	0–60	20	P
P5.14	Home position	reference unit	-(2 ³¹ -1)–(2 ³¹ -1)	0	P
P5.15*	Homing trigger command	-	0–1	0	P
P5.16	Homing associated action	-	0–3	0	P
P5.17	Target speed after homing	r/min	1–5000	100	P
P5.18	ACC/DEC time for target speed after homing	ms	0–32767	300	P
P5.19	Target position after homing	reference unit	-(2 ³¹ -1)–(2 ³¹ -1)	0	P
P5.20*	PTP trigger signal	-	-1–2048	-1	P
P5.21	Target speed 00	r/min	0–6000	20	P
P5.22	Target speed 01	r/min	0–6000	50	P
P5.23	Target speed 02	r/min	0–6000	100	P
P5.24	Target speed 03	r/min	0–6000	200	P
P5.25	Target speed 04	r/min	0–6000	300	P
P5.26	Target speed 05	r/min	0–6000	500	P
P5.27	Target speed 06	r/min	0–6000	600	P
P5.28	Target speed 07	r/min	0–6000	800	P
P5.29	Target speed 08	r/min	0–6000	1000	P
P5.30	Target speed 09	r/min	0–6000	1300	P
P5.31	Target speed 10	r/min	0–6000	1500	P
P5.32	Target speed 11	r/min	0–6000	1800	P
P5.33	Target speed 12	r/min	0–6000	2000	P
P5.34	Target speed 13	r/min	0–6000	2300	P

Function code	Parameter	Unit	Setting range	Default	Applicable mode
P5.35	Target speed 14	r/min	0–6000	2500	P
P5.36	Target speed 15	r/min	0–6000	3000	P
P5.37	ACC/DEC time 00	ms	0–32767	200	P
P5.38	ACC/DEC time 01	ms	0–32767	300	P
P5.39	ACC/DEC time 02	ms	0–32767	500	P
P5.40	ACC/DEC time 03	ms	0–32767	600	P
P5.41	ACC/DEC time 04	ms	0–32767	800	P
P5.42	ACC/DEC time 05	ms	0–32767	900	P
P5.43	ACC/DEC time 06	ms	0–32767	1000	P
P5.44	ACC/DEC time 07	ms	0–32767	1200	P
P5.45	ACC/DEC time 08	ms	0–32767	1500	P
P5.46	ACC/DEC time 09	ms	0–32767	2000	P
P5.47	ACC/DEC time 10	ms	0–32767	2500	P
P5.48	ACC/DEC time 11	ms	0–32767	3000	P
P5.49	ACC/DEC time 12	ms	0–32767	5000	P
P5.50	ACC/DEC time 13	ms	0–32767	8000	P
P5.51	ACC/DEC time 14	ms	0–32767	50	P
P5.52	ACC/DEC time 15	ms	0–32767	30	P
P5.53	Delay time 00	ms	0–32767	0	P
P5.54	Delay time 01	ms	0–32767	100	P
P5.55	Delay time 02	ms	0–32767	200	P
P5.56	Delay time 03	ms	0–32767	400	P
P5.57	Delay time 04	ms	0–32767	500	P
P5.58	Delay time 05	ms	0–32767	800	P
P5.59	Delay time 06	ms	0–32767	1000	P
P5.60	Delay time 07	ms	0–32767	1500	P
P5.61	Delay time 08	ms	0–32767	2000	P
P5.62	Delay time 09	ms	0–32767	2500	P
P5.63	Delay time 10	ms	0–32767	3000	P
P5.64	Delay time 11	ms	0–32767	3500	P
P5.65	Delay time 12	ms	0–32767	4000	P
P5.66	Delay time 13	ms	0–32767	4500	P
P5.67	Delay time 14	ms	0–32767	5000	P
P5.68	Delay time 15	ms	0–32767	5500	P
P5.69	PTP control buffer switch	-	0–1	0	P

Function code	Parameter	Unit	Setting range	Default	Applicable mode
P5.70	Disk single-turn resolution	pulse	$-(2^{31}-1)-(2^{31}-1)$	10000	P
P5.71	Disk homing switch	-	0-3	0	P
P5.72	Super multiturn mode	-	0-1	0	P
P5.73	Digital trigger mode for PTP control	-	0-1	0	P
P5.74	Digital output mode for PTP control	-	0-4	0	P
P5.75	Suspend PTP control	-	0-1	0	P
P6 Application functions					
P6.00	Forward low jogging speed	r/min	0-6000	5	P
P6.01	Reverse low jogging speed	r/min	-6000-0	-5	P
P6.02	Data latching switch	-	0-1	0	P
P6.03	Save position latching	-	0-1	0	P
P6.04	Forward high jogging speed	r/min	0-6000	60	P
P6.05	Reverse high jogging speed	r/min	-6000-0	-60	P
P6.06	Enable terminal jogging	-	0-1	1	P
P6.20	Turret switch	-	0-1	0	P
P6.21	Knives per turret	-	1-128	16	P
P6.22	Pulses per turret rotation	reference unit	$2-(2^{31}-1)$	10000	P
P6.23	Turret start point	reference unit	$-(2^{31}-2)-(2^{31}-2)$	0	P
P6.30	Gantry synchronization switch	-	0-1	0	P
P6.31	Speed control gain for gantry synchronization	Hz	0.0-3276.7	0	P
P6.32	Speed control integral for gantry synchronization	ms	0.1-1000	1000	P
P6.33	Position control gain for gantry synchronization	1/s	0.0-3276.7	1000	P
P6.34	Torque filter for gantry synchronization compensation	ms	0.00-64.00	0.00	P

Function code	Parameter	Unit	Setting range	Default	Applicable mode
P6.35	Speed filter for gantry synchronization compensation	ms	0.00–64.00	0.00	P
P6.36	Bandwidth ratio for gantry synchronization control	%	0–1000	0	P
P6.37	Master/slave node for gantry synchronization	-	0–1	0	P
P6.38	Retreat distance for gantry synchronization alignment	reference unit	$-(2^{31}-2)-(2^{31}-2)$	10000	P
P6.39	Retreat speed for gantry synchronization alignment	r/min	1–200	60	P
P6.40	Approaching speed for gantry synchronization alignment	r/min	1–60	5	P
P6.41	Gantry alignment direction	-	0–1	0	P
PtP0 PTP control					
PtP0.00	Control word of segment 00	-	0–0x7FFFFFFF	0x00000000	P
PtP0.01	Position of segment 00	reference unit	$-(2^{31}-1)-(2^{31}-1)$	0	P
PtP0.02	Control word of segment 01	-	0–0x7FFFFFFF	0x00000000	P
PtP0.03	Position of segment 01	reference unit	$-(2^{31}-1)-(2^{31}-1)$	0	P
PtP0.04	Control word of segment 02	-	0–0x7FFFFFFF	0x00000000	P
PtP0.05	Position of segment 02	reference unit	$-(2^{31}-1)-(2^{31}-1)$	0	P
PtP0.06	Control word of segment 03	-	0–0x7FFFFFFF	0x00000000	P
PtP0.07	Position of segment 03	reference unit	$-(2^{31}-1)-(2^{31}-1)$	0	P
PtP0.08	Control word of segment 04	-	0–0x7FFFFFFF	0x00000000	P
PtP0.09	Position of segment 04	reference unit	$-(2^{31}-1)-(2^{31}-1)$	0	P
PtP0.10	Control word of segment 05	-	0–0x7FFFFFFF	0x00000000	P

Function code	Parameter	Unit	Setting range	Default	Applicable mode
PtP0.11	Position of segment 05	reference unit	$-(2^{31}-1)-(2^{31}-1)$	0	P
PtP0.12	Control word of segment 06	-	0-0x7FFFFFFF	0x00000000	P
PtP0.13	Position of segment 06	reference unit	$-(2^{31}-1)-(2^{31}-1)$	0	P
PtP0.14	Control word of segment 07	-	0-0x7FFFFFFF	0x00000000	P
PtP0.15	Position of segment 07	reference unit	$-(2^{31}-1)-(2^{31}-1)$	0	P
PtP0.16	Control word of segment 08	-	0-0x7FFFFFFF	0x00000000	P
PtP0.17	Position of segment 08	reference unit	$-(2^{31}-1)-(2^{31}-1)$	0	P
PtP0.18	Control word of segment 09	-	0-0x7FFFFFFF	0x00000000	P
PtP0.19	Position of segment 09	reference unit	$-(2^{31}-1)-(2^{31}-1)$	0	P
PtP0.20	Control word of segment 10	-	0-0x7FFFFFFF	0x00000000	P
PtP0.21	Position of segment 10	reference unit	$-(2^{31}-1)-(2^{31}-1)$	0	P
PtP0.22	Control word of segment 11	-	0-0x7FFFFFFF	0x00000000	P
PtP0.23	Position of segment 11	reference unit	$-(2^{31}-1)-(2^{31}-1)$	0	P
PtP0.24	Control word of segment 12	-	0-0x7FFFFFFF	0x00000000	P
PtP0.25	Position of segment 12	reference unit	$-(2^{31}-1)-(2^{31}-1)$	0	P
PtP0.26	Control word of segment 13	-	0-0x7FFFFFFF	0x00000000	P
PtP0.27	Position of segment 13	reference unit	$-(2^{31}-1)-(2^{31}-1)$	0	P
PtP0.28	Control word of segment 14	-	0-0x7FFFFFFF	0x00000000	P
PtP0.29	Position of segment 14	reference unit	$-(2^{31}-1)-(2^{31}-1)$	0	P
PtP0.30	Control word of segment 15	-	0-0x7FFFFFFF	0x00000000	P
PtP0.31	Position of segment 15	reference unit	$-(2^{31}-1)-(2^{31}-1)$	0	P
PtP0.32	Control word of segment 16	-	0-0x7FFFFFFF	0x00000000	P
PtP0.33	Position of segment 16	reference unit	$-(2^{31}-1)-(2^{31}-1)$	0	P
PtP0.34	Control word of segment 17	-	0-0x7FFFFFFF	0x00000000	P

Function code	Parameter	Unit	Setting range	Default	Applicable mode
PtP0.35	Position of segment 17	reference unit	$-(2^{31}-1)-(2^{31}-1)$	0	P
PtP0.36	Control word of segment 18	-	0-0x7FFFFFFF	0x00000000	P
PtP0.37	Position of segment 18	reference unit	$-(2^{31}-1)-(2^{31}-1)$	0	P
PtP0.38	Control word of segment 19	-	0-0x7FFFFFFF	0x00000000	P
PtP0.39	Position of segment 19	reference unit	$-(2^{31}-1)-(2^{31}-1)$	0	P
PtP0.40	Control word of segment 20	-	0-0x7FFFFFFF	0x00000000	P
PtP0.41	Position of segment 20	reference unit	$-(2^{31}-1)-(2^{31}-1)$	0	P
PtP0.42	Control word of segment 21	-	0-0x7FFFFFFF	0x00000000	P
PtP0.43	Position of segment 21	reference unit	$-(2^{31}-1)-(2^{31}-1)$	0	P
PtP0.44	Control word of segment 22	-	0-0x7FFFFFFF	0x00000000	P
PtP0.45	Position of segment 22	reference unit	$-(2^{31}-1)-(2^{31}-1)$	0	P
PtP0.46	Control word of segment 23	-	0-0x7FFFFFFF	0x00000000	P
PtP0.47	Position of segment 23	reference unit	$-(2^{31}-1)-(2^{31}-1)$	0	P
PtP0.48	Control word of segment 24	-	0-0x7FFFFFFF	0x00000000	P
PtP0.49	Position of segment 24	reference unit	$-(2^{31}-1)-(2^{31}-1)$	0	P
PtP0.50	Control word of segment 25	-	0-0x7FFFFFFF	0x00000000	P
PtP0.51	Position of segment 25	reference unit	$-(2^{31}-1)-(2^{31}-1)$	0	P
PtP0.52	Control word of segment 26	-	0-0x7FFFFFFF	0x00000000	P
PtP0.53	Position of segment 26	reference unit	$-(2^{31}-1)-(2^{31}-1)$	0	P
PtP0.54	Control word of segment 27	-	0-0x7FFFFFFF	0x00000000	P
PtP0.55	Position of segment 27	reference unit	$-(2^{31}-1)-(2^{31}-1)$	0	P
PtP0.56	Control word of segment 28	-	0-0x7FFFFFFF	0x00000000	P
PtP0.57	Position of segment 28	reference unit	$-(2^{31}-1)-(2^{31}-1)$	0	P
PtP0.58	Control word of segment 29	-	0-0x7FFFFFFF	0x00000000	P

Function code	Parameter	Unit	Setting range	Default	Applicable mode
PtP0.59	Position of segment 29	reference unit	$-(2^{31}-1)-(2^{31}-1)$	0	P
PtP0.60	Control word of segment 30	-	0-0x7FFFFFFF	0x00000000	P
PtP0.61	Position of segment 30	reference unit	$-(2^{31}-1)-(2^{31}-1)$	0	P
PtP0.62	Control word of segment 31	-	0-0x7FFFFFFF	0x00000000	P
PtP0.63	Position of segment 31	reference unit	$-(2^{31}-1)-(2^{31}-1)$	0	P
PtP0.64	Control word of segment 32	-	0-0x7FFFFFFF	0x00000000	P
PtP0.65	Position of segment 32	reference unit	$-(2^{31}-1)-(2^{31}-1)$	0	P
PtP0.66	Control word of segment 33	-	0-0x7FFFFFFF	0x00000000	P
PtP0.67	Position of segment 33	reference unit	$-(2^{31}-1)-(2^{31}-1)$	0	P
PtP0.68	Control word of segment 34	-	0-0x7FFFFFFF	0x00000000	P
PtP0.69	Position of segment 34	reference unit	$-(2^{31}-1)-(2^{31}-1)$	0	P
PtP0.70	Control word of segment 35	-	0-0x7FFFFFFF	0x00000000	P
PtP0.71	Position of segment 35	reference unit	$-(2^{31}-1)-(2^{31}-1)$	0	P
PtP0.72	Control word of segment 36	-	0-0x7FFFFFFF	0x00000000	P
PtP0.73	Position of segment 36	reference unit	$-(2^{31}-1)-(2^{31}-1)$	0	P
PtP0.74	Control word of segment 37	-	0-0x7FFFFFFF	0x00000000	P
PtP0.75	Position of segment 37	reference unit	$-(2^{31}-1)-(2^{31}-1)$	0	P
PtP0.76	Control word of segment 38	-	0-0x7FFFFFFF	0x00000000	P
PtP0.77	Position of segment 38	reference unit	$-(2^{31}-1)-(2^{31}-1)$	0	P
PtP0.78	Control word of segment 39	-	0-0x7FFFFFFF	0x00000000	P
PtP0.79	Position of segment 39	reference unit	$-(2^{31}-1)-(2^{31}-1)$	0	P
PtP0.80	Control word of segment 40	-	0-0x7FFFFFFF	0x00000000	P
PtP0.81	Position of segment 40	reference unit	$-(2^{31}-1)-(2^{31}-1)$	0	P
PtP0.82	Control word of segment 41	-	0-0x7FFFFFFF	0x00000000	P

Function code	Parameter	Unit	Setting range	Default	Applicable mode
PtP0.83	Position of segment 41	reference unit	$-(2^{31}-1)-(2^{31}-1)$	0	P
PtP0.84	Control word of segment 42	-	0-0x7FFFFFFF	0x00000000	P
PtP0.85	Position of segment 42	reference unit	$-(2^{31}-1)-(2^{31}-1)$	0	P
PtP0.86	Control word of segment 43	-	0-0x7FFFFFFF	0x00000000	P
PtP0.87	Position of segment 43	reference unit	$-(2^{31}-1)-(2^{31}-1)$	0	P
PtP0.88	Control word of segment 44	-	0-0x7FFFFFFF	0x00000000	P
PtP0.89	Position of segment 44	reference unit	$-(2^{31}-1)-(2^{31}-1)$	0	P
PtP0.90	Control word of segment 45	-	0-0x7FFFFFFF	0x00000000	P
PtP0.91	Position of segment 45	reference unit	$-(2^{31}-1)-(2^{31}-1)$	0	P
PtP0.92	Control word of segment 46	-	0-0x7FFFFFFF	0x00000000	P
PtP0.93	Position of segment 46	reference unit	$-(2^{31}-1)-(2^{31}-1)$	0	P
PtP0.94	Control word of segment 47	-	0-0x7FFFFFFF	0x00000000	P
PtP0.95	Position of segment 47	reference unit	$-(2^{31}-1)-(2^{31}-1)$	0	P
PtP0.96	Control word of segment 48	-	0-0x7FFFFFFF	0x00000000	P
PtP0.97	Position of segment 48	reference unit	$-(2^{31}-1)-(2^{31}-1)$	0	P
PtP0.98	Control word of segment 49	-	0-0x7FFFFFFF	0x00000000	P
PtP0.99	Position of segment 49	reference unit	$-(2^{31}-1)-(2^{31}-1)$	0	P
PtP1 PTP control					
PtP1.00	Control word of segment 50	-	0-0x7FFFFFFF	0x00000000	P
PtP1.01	Position of segment 50	reference unit	$-(2^{31}-1)-(2^{31}-1)$	0	P
PtP1.02	Control word of segment 51	-	0-0x7FFFFFFF	0x00000000	P
PtP1.03	Position of segment 51	reference unit	$-(2^{31}-1)-(2^{31}-1)$	0	P
PtP1.04	Control word of segment 52	-	0-0x7FFFFFFF	0x00000000	P
PtP1.05	Position of segment 52	reference unit	$-(2^{31}-1)-(2^{31}-1)$	0	P

Function code	Parameter	Unit	Setting range	Default	Applicable mode
PtP1.06	Control word of segment 53	-	0-0x7FFFFFFF	0x00000000	P
PtP1.07	Position of segment 53	reference unit	$-(2^{31}-1)-(2^{31}-1)$	0	P
PtP1.08	Control word of segment 54	-	0-0x7FFFFFFF	0x00000000	P
PtP1.09	Position of segment 54	reference unit	$-(2^{31}-1)-(2^{31}-1)$	0	P
PtP1.10	Control word of segment 55	-	0-0x7FFFFFFF	0x00000000	P
PtP1.11	Position of segment 55	reference unit	$-(2^{31}-1)-(2^{31}-1)$	0	P
PtP1.12	Control word of segment 56	-	0-0x7FFFFFFF	0x00000000	P
PtP1.13	Position of segment 56	reference unit	$-(2^{31}-1)-(2^{31}-1)$	0	P
PtP1.14	Control word of segment 57	-	0-0x7FFFFFFF	0x00000000	P
PtP1.15	Position of segment 57	reference unit	$-(2^{31}-1)-(2^{31}-1)$	0	P
PtP1.16	Control word of segment 58	-	0-0x7FFFFFFF	0x00000000	P
PtP1.17	Position of segment 58	reference unit	$-(2^{31}-1)-(2^{31}-1)$	0	P
PtP1.18	Control word of segment 59	-	0-0x7FFFFFFF	0x00000000	P
PtP1.19	Position of segment 59	reference unit	$-(2^{31}-1)-(2^{31}-1)$	0	P
PtP1.20	Control word of segment 60	-	0-0x7FFFFFFF	0x00000000	P
PtP1.21	Position of segment 60	reference unit	$-(2^{31}-1)-(2^{31}-1)$	0	P
PtP1.22	Control word of segment 61	-	0-0x7FFFFFFF	0x00000000	P
PtP1.23	Position of segment 61	reference unit	$-(2^{31}-1)-(2^{31}-1)$	0	P
PtP1.24	Control word of segment 62	-	0-0x7FFFFFFF	0x00000000	P
PtP1.25	Position of segment 62	reference unit	$-(2^{31}-1)-(2^{31}-1)$	0	P
PtP1.26	Control word of segment 63	-	0-0x7FFFFFFF	0x00000000	P
PtP1.27	Position of segment 63	reference unit	$-(2^{31}-1)-(2^{31}-1)$	0	P
PtP1.28	Control word of segment 64	-	0-0x7FFFFFFF	0x00000000	P
PtP1.29	Position of segment 64	reference unit	$-(2^{31}-1)-(2^{31}-1)$	0	P

Function code	Parameter	Unit	Setting range	Default	Applicable mode
PtP1.30	Control word of segment 65	-	0-0x7FFFFFFF	0x00000000	P
PtP1.31	Position of segment 65	reference unit	$-(2^{31}-1)-(2^{31}-1)$	0	P
PtP1.32	Control word of segment 66	-	0-0x7FFFFFFF	0x00000000	P
PtP1.33	Position of segment 66	reference unit	$-(2^{31}-1)-(2^{31}-1)$	0	P
PtP1.34	Control word of segment 67	-	0-0x7FFFFFFF	0x00000000	P
PtP1.35	Position of segment 67	reference unit	$-(2^{31}-1)-(2^{31}-1)$	0	P
PtP1.36	Control word of segment 68	-	0-0x7FFFFFFF	0x00000000	P
PtP1.37	Position of segment 68	reference unit	$-(2^{31}-1)-(2^{31}-1)$	0	P
PtP1.38	Control word of segment 69	-	0-0x7FFFFFFF	0x00000000	P
PtP1.39	Position of segment 69	reference unit	$-(2^{31}-1)-(2^{31}-1)$	0	P
PtP1.40	Control word of segment 70	-	0-0x7FFFFFFF	0x00000000	P
PtP1.41	Position of segment 70	reference unit	$-(2^{31}-1)-(2^{31}-1)$	0	P
PtP1.42	Control word of segment 71	-	0-0x7FFFFFFF	0x00000000	P
PtP1.43	Position of segment 71	reference unit	$-(2^{31}-1)-(2^{31}-1)$	0	P
PtP1.44	Control word of segment 72	-	0-0x7FFFFFFF	0x00000000	P
PtP1.45	Position of segment 72	reference unit	$-(2^{31}-1)-(2^{31}-1)$	0	P
PtP1.46	Control word of segment 73	-	0-0x7FFFFFFF	0x00000000	P
PtP1.47	Position of segment 73	reference unit	$-(2^{31}-1)-(2^{31}-1)$	0	P
PtP1.48	Control word of segment 74	-	0-0x7FFFFFFF	0x00000000	P
PtP1.49	Position of segment 74	reference unit	$-(2^{31}-1)-(2^{31}-1)$	0	P
PtP1.50	Control word of segment 75	-	0-0x7FFFFFFF	0x00000000	P
PtP1.51	Position of segment 75	reference unit	$-(2^{31}-1)-(2^{31}-1)$	0	P
PtP1.52	Control word of segment 76	-	0-0x7FFFFFFF	0x00000000	P

Function code	Parameter	Unit	Setting range	Default	Applicable mode
PtP1.53	Position of segment 76	reference unit	$-(2^{31}-1)-(2^{31}-1)$	0	P
PtP1.54	Control word of segment 77	-	0-0x7FFFFFFF	0x00000000	P
PtP1.55	Position of segment 77	reference unit	$-(2^{31}-1)-(2^{31}-1)$	0	P
PtP1.56	Control word of segment 78	-	0-0x7FFFFFFF	0x00000000	P
PtP1.57	Position of segment 78	reference unit	$-(2^{31}-1)-(2^{31}-1)$	0	P
PtP1.58	Control word of segment 79	-	0-0x7FFFFFFF	0x00000000	P
PtP1.59	Position of segment 79	reference unit	$-(2^{31}-1)-(2^{31}-1)$	0	P
PtP1.60	Control word of segment 80	-	0-0x7FFFFFFF	0x00000000	P
PtP1.61	Position of segment 80	reference unit	$-(2^{31}-1)-(2^{31}-1)$	0	P
PtP1.62	Control word of segment 81	-	0-0x7FFFFFFF	0x00000000	P
PtP1.63	Position of segment 81	reference unit	$-(2^{31}-1)-(2^{31}-1)$	0	P
PtP1.64	Control word of segment 82	-	0-0x7FFFFFFF	0x00000000	P
PtP1.65	Position of segment 82	reference unit	$-(2^{31}-1)-(2^{31}-1)$	0	P
PtP1.66	Control word of segment 83	-	0-0x7FFFFFFF	0x00000000	P
PtP1.67	Position of segment 83	reference unit	$-(2^{31}-1)-(2^{31}-1)$	0	P
PtP1.68	Control word of segment 84	-	0-0x7FFFFFFF	0x00000000	P
PtP1.69	Position of segment 84	reference unit	$-(2^{31}-1)-(2^{31}-1)$	0	P
PtP1.70	Control word of segment 85	-	0-0x7FFFFFFF	0x00000000	P
PtP1.71	Position of segment 85	reference unit	$-(2^{31}-1)-(2^{31}-1)$	0	P
PtP1.72	Control word of segment 86	-	0-0x7FFFFFFF	0x00000000	P
PtP1.73	Position of segment 86	reference unit	$-(2^{31}-1)-(2^{31}-1)$	0	P
PtP1.74	Control word of segment 87	-	0-0x7FFFFFFF	0x00000000	P
PtP1.75	Position of segment 87	reference unit	$-(2^{31}-1)-(2^{31}-1)$	0	P
PtP1.76	Control word of segment 88	-	0-0x7FFFFFFF	0x00000000	P

Function code	Parameter	Unit	Setting range	Default	Applicable mode
PtP1.77	Position of segment 88	reference unit	$-(2^{31}-1)-(2^{31}-1)$	0	P
PtP1.78	Control word of segment 89	-	0-0x7FFFFFFF	0x00000000	P
PtP1.79	Position of segment 89	reference unit	$-(2^{31}-1)-(2^{31}-1)$	0	P
PtP1.80	Control word of segment 90	-	0-0x7FFFFFFF	0x00000000	P
PtP1.81	Position of segment 90	reference unit	$-(2^{31}-1)-(2^{31}-1)$	0	P
PtP1.82	Control word of segment 91	-	0-0x7FFFFFFF	0x00000000	P
PtP1.83	Position of segment 91	reference unit	$-(2^{31}-1)-(2^{31}-1)$	0	P
PtP1.84	Control word of segment 92	-	0-0x7FFFFFFF	0x00000000	P
PtP1.85	Position of segment 92	reference unit	$-(2^{31}-1)-(2^{31}-1)$	0	P
PtP1.86	Control word of segment 93	-	0-0x7FFFFFFF	0x00000000	P
PtP1.87	Position of segment 93	reference unit	$-(2^{31}-1)-(2^{31}-1)$	0	P
PtP1.88	Control word of segment 94	-	0-0x7FFFFFFF	0x00000000	P
PtP1.89	Position of segment 94	reference unit	$-(2^{31}-1)-(2^{31}-1)$	0	P
PtP1.90	Control word of segment 95	-	0-0x7FFFFFFF	0x00000000	P
PtP1.91	Position of segment 95	reference unit	$-(2^{31}-1)-(2^{31}-1)$	0	P
PtP1.92	Control word of segment 96	-	0-0x7FFFFFFF	0x00000000	P
PtP1.93	Position of segment 96	reference unit	$-(2^{31}-1)-(2^{31}-1)$	0	P
PtP1.94	Control word of segment 97	-	0-0x7FFFFFFF	0x00000000	P
PtP1.95	Position of segment 97	reference unit	$-(2^{31}-1)-(2^{31}-1)$	0	P
PtP1.96	Control word of segment 98	-	0-0x7FFFFFFF	0x00000000	P
PtP1.97	Position of segment 98	reference unit	$-(2^{31}-1)-(2^{31}-1)$	0	P
PtP1.98	Control word of segment 99	-	0-0x7FFFFFFF	0x00000000	P
PtP1.99	Position of segment 99	reference unit	$-(2^{31}-1)-(2^{31}-1)$	0	P

Function code	Parameter	Unit	Setting range	Default	Applicable mode
PtP2 PTP control					
PtP2.00	Control word of segment 100	-	0-0x7FFFFFFF	0x00000000	P
PtP2.01	Position of segment 100	reference unit	$-(2^{31}-1)-(2^{31}-1)$	0	P
PtP2.02	Control word of segment 101	-	0-0x7FFFFFFF	0x00000000	P
PtP2.03	Position of segment 101	reference unit	$-(2^{31}-1)-(2^{31}-1)$	0	P
PtP2.04	Control word of segment 102	-	0-0x7FFFFFFF	0x00000000	P
PtP2.05	Position of segment 102	reference unit	$-(2^{31}-1)-(2^{31}-1)$	0	P
PtP2.06	Control word of segment 103	-	0-0x7FFFFFFF	0x00000000	P
PtP2.07	Position of segment 103	reference unit	$-(2^{31}-1)-(2^{31}-1)$	0	P
PtP2.08	Control word of segment 104	-	0-0x7FFFFFFF	0x00000000	P
PtP2.09	Position of segment 104	reference unit	$-(2^{31}-1)-(2^{31}-1)$	0	P
PtP2.10	Control word of segment 105	-	0-0x7FFFFFFF	0x00000000	P
PtP2.11	Position of segment 105	reference unit	$-(2^{31}-1)-(2^{31}-1)$	0	P
PtP2.12	Control word of segment 106	-	0-0x7FFFFFFF	0x00000000	P
PtP2.13	Position of segment 106	reference unit	$-(2^{31}-1)-(2^{31}-1)$	0	P
PtP2.14	Control word of segment 107	-	0-0x7FFFFFFF	0x00000000	P
PtP2.15	Position of segment 107	reference unit	$-(2^{31}-1)-(2^{31}-1)$	0	P
PtP2.16	Control word of segment 108	-	0-0x7FFFFFFF	0x00000000	P
PtP2.17	Position of segment 108	reference unit	$-(2^{31}-1)-(2^{31}-1)$	0	P
PtP2.18	Control word of segment 109	-	0-0x7FFFFFFF	0x00000000	P
PtP2.19	Position of segment 109	reference unit	$-(2^{31}-1)-(2^{31}-1)$	0	P
PtP2.20	Control word of segment 110	-	0-0x7FFFFFFF	0x00000000	P
PtP2.21	Position of segment 110	reference unit	$-(2^{31}-1)-(2^{31}-1)$	0	P
PtP2.22	Control word of segment 111	-	0-0x7FFFFFFF	0x00000000	P

Function code	Parameter	Unit	Setting range	Default	Applicable mode
PtP2.23	Position of segment 111	reference unit	$-(2^{31}-1)-(2^{31}-1)$	0	P
PtP2.24	Control word of segment 112	-	0-0x7FFFFFFF	0x00000000	P
PtP2.25	Position of segment 112	reference unit	$-(2^{31}-1)-(2^{31}-1)$	0	P
PtP2.26	Control word of segment 113	-	0-0x7FFFFFFF	0x00000000	P
PtP2.27	Position of segment 113	reference unit	$-(2^{31}-1)-(2^{31}-1)$	0	P
PtP2.28	Control word of segment 114	-	0-0x7FFFFFFF	0x00000000	P
PtP2.29	Position of segment 114	reference unit	$-(2^{31}-1)-(2^{31}-1)$	0	P
PtP2.30	Control word of segment 115	-	0-0x7FFFFFFF	0x00000000	P
PtP2.31	Position of segment 115	reference unit	$-(2^{31}-1)-(2^{31}-1)$	0	P
PtP2.32	Control word of segment 116	-	0-0x7FFFFFFF	0x00000000	P
PtP2.33	Position of segment 116	reference unit	$-(2^{31}-1)-(2^{31}-1)$	0	P
PtP2.34	Control word of segment 117	-	0-0x7FFFFFFF	0x00000000	P
PtP2.35	Position of segment 117	reference unit	$-(2^{31}-1)-(2^{31}-1)$	0	P
PtP2.36	Control word of segment 118	-	0-0x7FFFFFFF	0x00000000	P
PtP2.37	Position of segment 118	reference unit	$-(2^{31}-1)-(2^{31}-1)$	0	P
PtP2.38	Control word of segment 119	-	0-0x7FFFFFFF	0x00000000	P
PtP2.39	Position of segment 119	reference unit	$-(2^{31}-1)-(2^{31}-1)$	0	P
PtP2.40	Control word of segment 120	-	0-0x7FFFFFFF	0x00000000	P
PtP2.41	Position of segment 120	reference unit	$-(2^{31}-1)-(2^{31}-1)$	0	P
PtP2.42	Control word of segment 121	-	0-0x7FFFFFFF	0x00000000	P
PtP2.43	Position of segment 121	reference unit	$-(2^{31}-1)-(2^{31}-1)$	0	P
PtP2.44	Control word of segment 122	-	0-0x7FFFFFFF	0x00000000	P
PtP2.45	Position of segment 122	reference unit	$-(2^{31}-1)-(2^{31}-1)$	0	P
PtP2.46	Control word of segment 123	-	0-0x7FFFFFFF	0x00000000	P

Function code	Parameter	Unit	Setting range	Default	Applicable mode
PtP2.47	Position of segment 123	reference unit	$-(2^{31}-1)-(2^{31}-1)$	0	P
PtP2.48	Control word of segment 124	-	0-0x7FFFFFFF	0x00000000	P
PtP2.49	Position of segment 124	reference unit	$-(2^{31}-1)-(2^{31}-1)$	0	P
PtP2.50	Control word of segment 125	-	$-(2^{31}-1)-(2^{31}-1)$	0x00000000	P
PtP2.51	Position of segment 125	reference unit	$-(2^{31}-1)-(2^{31}-1)$	0	P
PtP2.52	Control word of segment 126	-	0-0x7FFFFFFF	0x00000000	P
PtP2.53	Position of segment 126	reference unit	$-(2^{31}-1)-(2^{31}-1)$	0	P
PtP2.54	Control word of segment 127	-	0-0x7FFFFFFF	0x00000000	P
PtP2.55	Position of segment 127	reference unit	$-(2^{31}-1)-(2^{31}-1)$	0	P

10.2 Parameters about monitoring

The following table lists the parameters for monitoring servo drive status.

Function code	Parameter	Unit	Setting range	Applicable mode
R0 System monitoring				
R0.00	Motor speed	r/min	-9999.9–9999.9	PST
R0.01	Speed command	r/min	-9999.9–9999.9	PST
R0.02	Accumulated feedback pulses	reference unit	$-(2^{63}-1)-(2^{63}-1)$	P
R0.03	Accumulated command pulses	reference unit	$-(2^{63}-1)-(2^{63}-1)$	P
R0.04	Residual pulses	reference unit	$-(2^{31}-1)-(2^{31}-1)$	P
R0.05	Hybrid control deviation	reference unit	$-(2^3-1)-(2^{31}-1)$	P
R0.06	Current torque	%	-500.0–500.0	PST
R0.07	Main circuit DC voltage	V	0.0–1000.0	PST
R0.09	Output voltage	Vrms	0.0–1000.0	PST
R0.10	Output current	Arms	0.00–1000.00	PST
R0.11	Drive temperature	°C	-55.0–180.0	PST
R0.12	Torque limit	%	-500.0–500.0	PST
R0.13	Encoder feedback value	pulse	$0-(2^{32}-1)$	PST
R0.14	Rotor position relative to pulse Z	pulse	$0-(2^{31}-1)$	PST
R0.15	Load inertia ratio	%	0–10000	PST
R0.16	Output power	%	-500.0–500.0	PST
R0.17	Motor load ratio	%	0–500	PST
R0.18	Numerator of actual electronic gear ratio	-	$0-(2^{31}-1)$	P
R0.19	Denominator of actual electronic gear ratio	-	$1-(2^{31}-1)$	P
R0.20	Position command speed	r/min	-9999.9–9999.9	P
R0.21	Filtered motor speed	r/min	-9999.9–9999.9	PST
R0.22	PTP status	-	-1–4223	P
R0.23	Encoder absolute position feedback	pulse	$-(2^{31}-1)-(2^{31}-1)$	PST
R0.24	Encoder EEPROM status	-	0–3	PST
R0.25	Turns of multiturn encoder	-	-32768–32767	PST
R0.26	Encoder type	-	0–6	PST
R0.27	EtherCAT clock synchronization status	-	0–1	PST
R0.28	CANopen status machine	-	0–18	PST

Function code	Parameter	Unit	Setting range	Applicable mode
R0.30	System status	-	0-6	PST
R0.31	IGBT status	-	0-1	PST
R0.32	Current mode	-	0-2	PST
R0.33	Power-on time	s	$0-(2^{31}-1)$	PST
R0.34	Enabling time	s	$0-(2^{31}-1)$	PST
R0.35	DSP version no.	-	0.00-10.00	PST
R0.36	FPGA version no.	-	0.00-10.00	PST
R0.38	Drive SN 1	-	0-65535	PST
R0.39	Drive SN 2	-	0-65535	PST
R0.40	Drive SN 3	-	0-65535	PST
R0.41	Drive SN 4	-	0-65535	PST
R0.42	Drive SN 5	-	0-65535	PST
R0.43	Drive SN 6	-	0-65535	PST
R0.44	Absolute position in single grating ruler (or encoder 2) turn	pulse	$0-(2^{31}-1)$	PST
R0.45	Speed feedback from encoder 2	r/min	-9999.9-9999.9	PST
R0.46	Speed observer detection	r/min	-9999.9-9999.9	PST
R0.47	Speed observer feedback	r/min	-9999.9-9999.9	PST
R0.48	Torque from disturbance observer	%	-1000.0-1000.0	PST
R0.49	Fully-closed loop vibration suppressor compensation	r/min	-9999.9-9999.9	PST
R0.51	Real-time load inertia ratio	%	0-10000	PST
R0.52	Accumulated grating ruler (or encoder 2) position feedback (32-bit)	pulse	$-(2^{31}-1)-(2^{31}-1)$	PST
R0.53	Gantry synchronization position deviation	reference unit	$-(2^{31}-1)-(2^{31}-1)$	PST
R0.54	Grating ruler (or encoder 2) position feedback	pulse	$0-(2^{31}-1)$	PST
R0.55	Encoder turn deviation after multiturn position cleared	-	$-(2^{31}-1)-(2^{31}-1)$	PST
R0.56	Encoder feedback deviation after multiturn position cleared	pulse	$-(2^{31}-1)-(2^{31}-1)$	PST
R0.57	Accumulated grating ruler (or encoder 2) position feedback (64-bit)	pulse	$-(2^{63}-1)-(2^{63}-1)$	PST
R0.60	Medium-power motor temperature	°C	-55-200	PST

Function code	Parameter	Unit	Setting range	Applicable mode
R0.99	Fault code	-	-32768–32767	PST
R1 I/O monitoring				
R1.00	Digital input status	-	0x000–0x3FF	PST
R1.01	Digital output status	-	0x00–0x3F	PST
R1.02	Raw voltage of AI 1	V	-10.000–10.000	PST
R1.03	Raw voltage of AI 2	V	-10.000–10.000	PST
R1.05	Corrected voltage of AI 1	V	-10.000–10.000	PST
R1.06	Corrected voltage of AI 2	V	-10.000–10.000	PST
R1.08	Voltage of AO 1	V	-10.000–10.000	PST
R1.09	Voltage of AO 2	V	-10.000–10.000	PST
R1.11	Accumulated input pulses	reference unit	$-(2^{31}-1)-(2^{31}-1)$	PST
R1.12	Pulse position command	reference unit	$-(2^{31}-1)-(2^{31}-1)$	PST
R1.13	Pulse-corresponded speed command	r/min	-10000.0–10000.0	PST
R1.14	Analog compensation speed	r/min	-10000.0–10000.0	PST
R1.15	Analog compensation torque	%	-1000.0–1000.0	PST
R1.16	DI-captured encoder value	pulse	$-(2^{31}-1)-(2^{31}-1)$	PST
R3 Fault recording				
R3.00	Fault code	-	-	PST
R3.01	Power-on time before fault	h	$0-(2^{31}-1)$	PST
R3.02	Running time before fault	h	$0-(2^{31}-1)$	PST
R3.03	Motor speed before fault	r/min	-20000–20000	PST
R3.04	Speed command before fault	r/min	-20000–20000	PST
R3.05	Accumulated feedback pulses before fault	reference unit	$-(2^{31}-1)-(2^{31}-1)$	P
R3.06	Accumulated command pulses before fault	reference unit	$-(2^{31}-1)-(2^{31}-1)$	P
R3.07	Residual pulses before fault	reference unit	$-(2^{31}-1)-(2^{31}-1)$	P
R3.08	Output torque before fault	%	-500.0–500.0	PST
R3.09	Main circuit DC voltage before fault	V	0.0–1000.0	PST
R3.10	Output voltage before fault	Vrms	0.0–1000.0	PST
R3.11	Output current before fault	Arms	0.00–1000.00	PST
R3.20	Last fault code	-	-	PST
R3.21	2nd-last fault code	-	-	PST
R3.22	3rd-last fault code	-	-	PST

Function code	Parameter	Unit	Setting range	Applicable mode
R3.23	4th-last fault code	-	-	PST
R3.24	5th-last fault code	-	-	PST
R3.25	6th-last fault code	-	-	PST
R3.26	7th-last fault code	-	-	PST
R3.27	8th-last fault code	-	-	PST
R3.28	9th-last fault code	-	-	PST
R3.29	10th-last fault code	-	-	PST

10.3 Common monitoring parameters

P0.15	Meaning	Display	Unit	Corresponding to
[0]	Motor speed	SPdFb	r/min	R0.00
1	Speed command	SPdcNd	r/min	R0.01
2	Accumulated feedback pulses	PLSFB	reference unit	R0.02
3	Accumulated command pulses	PLScNd	reference unit	R0.03
4	Residual pulses	PLSEr1	reference unit	R0.04
5	Hybrid control deviation	PLSEr2	reference unit	R0.05
6	Current torque	ErqFb	%	R0.06
7	Main circuit DC voltage	UbUs1	V	R0.07
8	Output voltage	UoUe	Vrms	R0.09
9	Output current	IoUe	Arms	R0.10
10	Drive temperature	NdLtnP	°C	R0.11
11	Torque limit	ErqLte	%	R0.12
12	Encoder feedback value	EncFb	pulse	R0.13
13	Rotor position relative to pulse Z	EncAbs	pulse	R0.14
14	Load inertia ratio	J-r	%	R0.15
15	Output power	PobEr	%	R0.16
16	Motor load ratio	Load-r	%	R0.17
17	Numerator of actual electronic gear ratio	nUN	-	R0.18
18	Denominator of actual electronic gear ratio	dEN	-	R0.19
19	Position command speed	PLSSPd	r/min	R0.20
20	Instantaneous speed	SPdFbi	r/min	R0.21
21	PTP status	PtPStS	-	R0.22

10.4 Fault codes

A fault code is displayed in the format of ErXX-X, in which XX indicates the main code and X indicates the sub code.

For example, in , 01 indicates the main code and 0 indicates the sub code.

Fault code	Fault name	Attribute		
		History	Clearable	Enabling inhibited
Er01-0	IGBT fault	•		•
Er01-5	IPM fault	•		•
Er02-0	Encoder fault–Encoder communication exception	•		•
Er02-1	Encoder fault–Encoder feedback deviation too large	•		•
Er02-2	Encoder fault– Parity error	•		•
Er02-3	Encoder fault–CRC error	•		•
Er02-4	Encoder fault–Frame error	•		•
Er02-5	Encoder fault–Short frame error	•		•
Er02-6	Encoder fault–Encoder exception reporting	•		•
Er02-7	Encoder fault–Second-encoder timeout	•		•
Er02-8	Encoder fault–Encoder battery low-voltage alarm			
Er02-9	Encoder fault–Encoder battery undervoltage	•		•
Er02-a	Encoder fault–Encoder overheating	•		•
Er02-b	Encoder fault–Encoder EEPROM writing error	•		•
Er02-c	Encoder fault–No data in encoder EEPROM			•
Er02-d	Encoder fault–Encoder EEPROM data check error			•
Er03-0	Current sensor fault–Phase-U current sensor fault	•		•

Fault code	Fault name	Attribute		
		History	Clearable	Enabling inhibited
Er03-1	Current sensor fault–Phase-V current sensor fault	•		•
Er03-2	Current sensor fault–Phase-W current sensor fault	•		•
Er04-0	System initialization fault			•
Er05-1	Setting fault–Motor model not exist	•		•
Er05-2	Setting fault–Motor and drive model not match	•		•
Er05-3	Setting fault–Incorrect software limits	•	•	•
Er05-4	Setting fault–Incorrect homing mode	•		•
Er05-5	Setting fault–PTP-control travel overflow	•	•	•
Er07-0	Regenerative brake over-discharge	•	•	•
Er08-0	AI overvoltage fault–AI 1	•	•	•
Er08-1	AI overvoltage fault–AI 2	•	•	•
Er09-0	EEPROM fault–Read/write error			•
Er09-1	EEPROM fault–Data check error			•
Er10-0	Hardware fault–FPGA fault	•		•
Er10-1	Hardware fault–Communication card fault	•	•	•
Er10-2	Hardware fault–Ground short-connection fault	•		•
Er10-3	Hardware fault–External input fault	•	•	•
Er10-4	Hardware fault–Emergency stop fault	•	•	•
Er10-5	Hardware fault–RS485 communication fault	•	•	•
Er10-6	Hardware fault–AC power phase loss	•	•	•
Er11-0	Software fault– Motor control task re-entry	•		•
Er11-1	Software fault–Periodic task re-entry	•		•
Er11-2	Software fault–Illegal operation	•		•
Er12-0	I/O fault–Duplicate digital input assignment	•	•	•

Fault code	Fault name	Attribute		
		History	Clearable	Enabling inhibited
Er12-2	I/O fault–Pulse input frequency too high	•	•	•
Er13-0	Main circuit overvoltage	•	•	•
Er13-1	Main circuit undervoltage		•	•
Er14-0	Control power undervoltage		•	•
Er17-0	Drive overload	•	•	•
Er17-1	Drive overload 2	•	•	•
Er18-0	Motor overload	•	•	•
Er18-1	Motor overtemperature	•	•	•
Er19-0	Speed fault–Overspeed	•	•	•
Er19-1	Speed fault–CCW overspeed	•	•	•
Er19-2	Speed fault–CW overspeed	•	•	•
Er19-3	Speed fault–Overspeed parameter set incorrectly	•	•	•
Er19-4	Overspeed fault–Motor runaway	•		•
Er20-0	Speed deviation fault	•	•	•
Er21-0	Position overtravel–CCW		•	
Er21-1	Position overtravel–CW		•	
Er22-0	Position deviation fault	•	•	•
Er22-1	Hybrid control deviation too large	•	•	•
Er22-2	Position increment overflow	•		•
Er22-3	CANopen–Synchronization signal timeout	•	•	•
Er22-4	CANopen–Full position command buffer	•	•	•
Er23-0	Drive overtemperature	•	•	•
Er25-4	Application fault–Encoder offset angle test timeout	•	•	•
Er25-5	Application fault–Encoder offset angle test failed	•	•	•
Er25-6	Application fault–Homing offside	•	•	•
Er25-7	Application fault–Inertia identifying failed	•	•	•

Fault code	Fault name	Attribute		
		History	Clearable	Enabling inhibited
Er25-8	Application fault–Magnetic pole check failed	•	•	•
Er25-9	Application fault–Overtravel/overspeed in confirmation of magnetic pole check	•	•	•
Er25-a	Application fault–Out-of-range in magnetic pole check	•	•	•
Er26-0	CANopen fault–CANopen offline		•	
Er26-1	CANopen fault–SDO index not exist		•	
Er26-2	CANopen fault–SDO sub-index not exist		•	
Er26-3	CANopen fault–Incorrect SDO data length		•	
Er26-4	CANopen fault–SDO data out of range		•	
Er26-5	CANopen fault–Modification not allowed for read-only		•	
Er26-6	CANopen fault–Incorrect PDO mapping length		•	
Er26-7	CANopen fault–PDO mapping data not exist		•	
Er26-8	CANopen fault–PDO modification not allowed in operational state		•	
Er26-9	CANopen fault–PDO mapping not allowed		•	
Er26-a	CANopen fault–Synchronization signal too fast		•	
Er26-b	CANopen fault–Receiving fault		•	
Er26-c	CANopen fault–Sending fault		•	
Er26-d	CANopen fault–Duplicate synchronization signal		•	
Er26-e	CANopen fault–Bus load ratio too high		•	
Er26-f	CANopen fault–Incorrect parameter modification status		•	



Service line: 400-700-9997; 86-21-34637660 Website: www.invt-tech.com

INVT INDUSTRIAL TECHNOLOGY (SHANGHAI) CO.,LTD.

Building 1, 188 Xinjunhuan Road, Pujiang Town, Minhang District, Shanghai

- | | | | | |
|-------------------------------|-------|---------------------------------------|-----------------------------------|-------|
| Industrial Automation: | ■ VFD | ■ Servo & Motion Control | ■ Motor & Electric Spindle | ■ PLC |
| | ■ HMI | ■ Elevator Intelligent Control System | ■ Rail Transit Traction System | |
| Energy & Power: | ■ SVG | ■ Solar Inverter | ■ Online Energy Management System | ■ UPS |



66001-00640

Copyright© INVT.

Manual information may be subject to change without prior notice.

202009 (V1.2)